

*Medical sciences**Article*

DYNAMICS OF INDICATORS OF THE HUMAN CEREBELLAR CORTEX AT THE STAGES OF POSTNATAL ONTOGENESIS

*Balandin A.A., Zheleznov L.M., Balandina I.A., Borodulin D.V.*

3

*Materials of Conferences*

CORRELATION OF ANTHROPOMETRIC PARAMETERS IN PATIENTS WITH METABOLIC SYNDROME BEFORE ENDOSCOPIC GASTRO-BYPASS SURGERY

*Fursov A.B., Fursov R.A.*

5

*Short Reports*

PRIORITY TRENDS OF PREVENTION OF HIV INFECTION IN RUSSIAN PROVINCE (BY THE EXAMPLE OF STAVROPOL KRAI)

*Savchenko V.V., Kiseleva I.N.*

7

*Biological sciences**Article*

CHANGES IN THE REPRODUCTIVE SYSTEM OF RATS AND ITS GETS IN ANTENATAL PERIOD AFTER SESAME SEEDS OIL MEAL SUPPLEMENT

*Pavlova O.N., Garipov T.V., Pinaeva O.N., Supilnikov A.A., Yukhimets S.N.*

9

*Short Reports*

THE RESERCH OF QUANTITATIVE CONTENT OF ORGANIC ACID IN MULTIVITAMIN PLANT COLLECTION

*Marakhova A.I., Sergunova E.V., Stanishevskiy Ya.M.*

14

NET PRIMARY PRODUCTION OF DRY STEPPES OF TYVA REPUBLIC

*Sambuu A.D., Kirova N.A.*

16

*Physical and Mathematical sciences**Article*

WHAT IS THE ELECTRICAL CURRENT AND THE THERMAL ENERGY AS ONE OF THEM CAN MOVE TO ANOTHER AND BACK

*Sopov Yu.V.*

18

*Art Criticism**Article*

THE IMPORTANCE USE OF TRADITIONAL DECORATIVE APPLIED ART IN OF SCHOOL SYSTEM OF TRAINING TO ART, LABOR AND TECHNOLOGY

*Kamak A.O.*

22

*Culturology**Article*

FORMATION OF ECOLOGICAL CULTURE OF THE STUDENTS AT THE NATIONAL SCHOOL

*Khusainov Z.A.*

26

*Psychological sciences**Article*

COGNITIVE PROCESSES OF THE POLITICAL PSYCHE

*Bozadzhiev V.L.*

30

*Technical sciences**Article*

- MANAGERIAL NOVATIONS IN CONSTRUCTION USING INFORMATION-COMMUNICATION TECHNOLOGIES  
*Kunyaev N.E., Martinov L.M.* 33
- SCIENTIFIC AND EDUCATIONAL COMPONENTS WITHIN THE PROCESS OF SUSTAINABLE GARMENT DESIGN AND TECHNOLOGY DEVELOPMENT FOR PEOPLE WITH DISABILITIES  
*Tolmacheva G.V., Gerasimova J.L.* 38

*Materials of Conferences*

- FRACTURE SURFACES UNDER PLASTIC DEFORMATION  
*Udaev V.V., Frolova T.A., Frolov S.V.* 42

*Short Reports*

- RESEARCH OF METHODS OF PARAMETRIC OBJECT CHANGES  
*Vadutova F.A., Cherkashina Yu.A.* 43

*Ecological and conservancy**Materials of Conferences*

- SYSTEM PLANNING AND MANAGEMENT OF SHUTDOWN MAINTENANCE FOR CHEMICAL FACILITIES  
*Egorov S.Ya., Shirokova S.D., Egorov E.S., Betin E.A.* 46

*Economic sciences**Materials of Conferences*

- PECULIARITIES OF MODERNIZING RUSSIAN ECONOMY  
*Danilina E.I., Chebotarev V.E., Gorelov D.V., Malikova Y.I.* 47

*Pedagogical sciences**Materials of Conferences*

- EFFICIENCY OF MODERN DIDACTIC PRINCIPLES OF PERSONALITY-ORIENTED LEARNING TECHNOLOGIES IN HIGHER MEDICAL EDUCATION IN UKRAINE  
*Iermolenko T.I., Karnaukh E.V.* 50
- ACTIVIZATION OF STUDENTS' COGNITIVE ACTIVITY IN IT LESSONS REFERENCES  
*Kaldarova B.S., Daulenbaeva T.P.* 50

*Sociology**Materials of Conferences*

- YOUTH PRO-NATALIST POLICIES: SOCIAL AND ECONOMIC ASPECTS (CASE STUDY SOME REGIONS OF RUSSIA, FRANCE AND GERMANY)  
*Gokova O.V.* 52

*Legal sciences**Short Reports*

- RUSSIA AND THE ROME STATUTE OF THE INTERNATIONAL CRIMINAL COURT: RATIFICATION PROBLEMS  
*Gracheva R.O.* 55

## DYNAMICS OF INDICATORS OF THE HUMAN CEREBELLAR CORTEX AT THE STAGES OF POSTNATAL ONTOGENESIS

<sup>1</sup>Balandin A.A., <sup>2</sup>Zheleznov L.M., <sup>1</sup>Balandina I.A., <sup>1</sup>Borodulin D.V.

<sup>1</sup>Perm State Medical University n.a. academician E.A. Vagner, Perm, e-mail: balandinnauka@mail.ru;

<sup>2</sup>Orenburg State Medical University, Orenburg

---

The comparative analysis of thickness of the cerebellar cortex of people of both sexes, different ages. The main research method was morphometry of histologic specimen of cerebellum. It was found that thickness of the cortex cerebelli depends on the person's age, and its indicators uniformly decrease from the second period of adulthood to senium.

---

**Keywords:** cerebellar cortex, age periods, postnatal ontogenesis

Cerebellum as part of the nervous system has a large number of cellular and functional reserves. It is generally accepted that only a small percentage of neurons in the cerebellum are always active. A significant number of neurons and glial cells is functionally spare and its structural and functional activity increases by the action of various extreme factors. The need for in-depth research of age variation of thickness of the cerebellar cortex – the cause of our research.

The purpose of the research: is to make the comparative analysis of thickness of the cortex cerebelli at various stages of postnatal ontogenesis. The Research is based on an analysis of the results of craniometric, histologic and morphometric study of 268 corpses (males and females, aged 17 to 86 years). Research objects (208 corpses) were divided into five groups according to age periodization of human ontogenesis, adopted by the Seventh All-Union Conference on morphology, physiology and biochemistry APS the USSR (Moscow, 1965) to identify patterns of age-related changes of the cerebellar cortex. Criteria of research objects: Fatal abdominal or/and chest injury (and absence of head injuries); medical history of deceased, excluding the pathology of central or peripheral nervous system; death was no more than 24–36 hours ago; storage of corpses in the same conditions at a temperature +2 °C. Length and width of the skull were measured and craniotype was determined by value of the cranial index. Our research objects are mesaticephalic (medium-headed) with cranial (cephalic) index 75,0–79,9.

### Materials and methods of research

It found that the lateral area is the most damageable part of the cerebellum. In this area dysfunction of Purkinje cells and increasing the number of atypical neurons begins earlier and more intensely. Therefore tissue of this area was taken for research (superior semilunar lobe of both hemispheres of the cerebellum). Biomaterial was fixed in 10% neutral formalin solution, was dehydrated in alcohols of increasing concentration, and was paraffin-

embedded to make a 5-micron-thick histologic specimen. Tissue sections were stained with H&E, by Van Gieson's method. Sections were stained by Nissl method to examine basophil substance, chromatin, neuron's nucleoli. Some tissue sections were stained by Hekvist's method or Gross-Bilshovsky method to examine neurofibrils, dendrites and an axon. Stained Hystologic specimens were viewed by ×60, ×150, ×600 magnification using a CAM V200 «Micros Handelsgesellschaft m.b.H.» microscope camera. Results were processed using dedicated software Bio Vision 4.0 version. Microsoft Excel «Biostat» was used for statistical research.

### Results of research and their discussion

Branched sulcuses filled with elements of the pia mater, and gyruses with gray matter on the surface were viewed by microscope. Gyrus' White matter is nerve fibers and glial cells. Three layers of the cerebellar cortex were viewed: an external molecular layer, a middle ganglionic layer and an internal granular layer. Cells of the molecular layer were located at a great distance from each other. Nucleoli of the granular layer cells visualized very clearly. Purkinje cells of the middle ganglionic layer were placed strictly in a row. Neuronal processes poorly visualized by H&E staining.

Thickness of the right cerebellar hemisphere cortex of male corpses was: 667,47 ± 17,70 micron during the adolescence, 666,45 ± 16,72 micron during the first period of adulthood, 623,09 ± 15,51 micron during the second period of adulthood, 591,88 ± 18,72 micron during the advanced age, and 536,70 ± 13,87 micron during the senium. Thickness of the right cerebellar hemisphere cortex of female corpses was: 661,79 ± 17,97 micron during the adolescence, 659,86 ± 16,33 micron during the first period of adulthood, 615,74 ± 18,13 micron during the second period of adulthood, 588,10 ± 19,68 micron during the advanced age, and 525,28 ± 12,70 micron during the senium. The maximum thickness of the right cerebellar cortex (796 micron in men and 792 micron in women) was identified in the

adolescence. The minimal thickness of the cerebellar cortex (434 micron in men and 433 micron in women) was identified in the senium.

Thickness of the left cerebellar hemisphere cortex of male corpses was:  $665,26 \pm 17,65$  micron during the adolescence,  $663,55 \pm 16,81$  micron during the first period of adulthood,  $618,65 \pm 15,39$  micron during the second period of adulthood,  $588,76 \pm 18,66$  micron during the advanced age, and  $533,35 \pm 13,84$  micron during the senium. Thickness of the left cerebellar hemisphere cortex of female corpses was:  $659,42 \pm 17,91$  micron during the adolescence,  $657,05 \pm 16,31$  micron during the first period of adulthood,  $611,61 \pm 16,59$  micron during the second period of adulthood,  $584,10 \pm 19,69$  micron during the advanced age, and  $521,17 \pm 12,62$  micron during the senium. The maximum thickness of the left cerebellar cortex (790 micron in men and 787 micron in women) was identified in the adolescence. The minimal thickness of the left cerebellar cortex (428 micron in men and 428 micron in women) was identified in the senium.

### Conclusion

Research of quantitative changes in thickness of cortex cerebelli may be used as a basis

for identifying patterns of age anatomy of the cerebellum (age involution). We assume that degeneration of the cerebellar cortex fibers is the reason of involution. Known, that male cerebellum is larger than female one. Scientists attribute this to the difference between the size of the skull. We found that thickness of the male cerebellar cortex is more than thickness of female cerebellar cortex. We observed hemispheric asymmetry of the thickness of the cerebellar cortex in all age periods with greater thickness in the right hemisphere. Scientists and researchers point out that the hemispheric asymmetry is at the heart of work of the entire brain. In this way, all these thickness parameters of the cerebellar cortex will be used as indicators of the norm in diagnostic and medical work.

### References

1. Mravec B. Cerebellum: structure, functions and its role in neuropsychiatric diseases *Psychiatrie*. – 2008. – T. 12. – № 1. – C. 18–27.
2. Saab C.Y., Willis W.D. The cerebellum: organization, functions and its role in nociception // *Brain Research Reviews*. – 2003. – T. 42. – № 1. – C. 85–95.
3. Sudarov A., Joyner A.L. Cerebellum morphogenesis: the foliation pattern is orchestrated by multi-cellular anchoring centers // *Neural Development*. – 2007. – 2:26 <http://www.neuraldevelopment.com/content/2>.

*Materials of Conferences***CORRELATION OF ANTHROPOMETRIC PARAMETERS IN PATIENTS WITH METABOLIC SYNDROME BEFORE ENDOSCOPIC GASTRO-BYPASS SURGERY**

Fursov A.B., Fursov R.A.

*Medical University Astana,  
Astana, e-mail: fabcom@yandex.ru*

Urgency of this research is defined by the necessity of correct selection of patients with obesity and metabolic syndrome for surgical treatment aimed to lower their weight. The objective of this work is to study anthropometric indicators of overweighted patients with clinical picture of metabolic syndrome.

Material and methods of research. This work presents observation over 124 patients with obesity. Among them 35 individuals were selected for bypass surgery. The purpose of surgical treatment for this group was to influence the flow of diseases, related to obesity via significant decrease in body mass. The second reason therefore was to improve life quality of patients significantly and move aside the threat of premature death. The necessity of bariatric surgeries was studied strictly within medical aspect that has medical (not cosmetic or aesthetic) indication. Examination of anamnestic data among men and women has revealed the following results: Most of the observed women (85%) think that their weigh grew after they gave birth. At the same time, most male patients (78%) tend to relate their obesity with decrease in physical strain and giving up of sporting activity.

All patients who were selected for surgery had taken multiple efforts to decrease their weight independently. For example, diet and medical starving was used by 31 patient that equals 88,6% of the whole research group. However, weight loss was insignificant (around 8–10 kgs). In 1–2 months their body mass restored. Apart from that, 35 patients (100%) took several courses of conservative medicamental therapy. They took various anti-lipid preparations and additives. However, no one achieved weight decrease by more than 15 kgs. The described circumstances served as a reason for their application to a surgeon in order to take surgical weight correction. In this work efficiency of surgical treatment was defined by three diagnostic markers. These indexes that describe decrease in excess body mass (BM); effect of surgery upon flow of diseases, related to obesity; indexes that reflect changes in life quality. Laparoscopic technic of surgery was used as a standard method in all types of bariatric surgeries thus being the basic method of selection in our research.

The average age of all surveyed patients is  $39 \pm 6,7$  years. Age of the operated and monitored patients varied widely from 21 to 58 years. Our study analyzed by sex composition, who underwent surgery were as follows: men accounted for a group of 8 patients (22,9%), women – 27 patients (77,1%). Moreover, in the young group of 21 to 30 years, females dominated. So the youngest and the oldest patients operated within our study were women (21 and 58 years, respectively). Men in the age plan took a position with a predominance of middle age. Thus, the youngest man to operate with overweight recorded was in the age of 31 year. The most senior in age was operated in 45 years. Most of the patients affected by the number of bariatric surgery in occasion of excess weight are registered in the age period from 40 to 45 years. Next, are patients aged from 30 to 35 years. Results of statistical analysis showed rather uneven picture of the distribution of all persons by age. By the method of variation statistics, we found, that the average value of the weight is body mass (M) of patients observed was 120 kg. The average statistical deviation (m) was equal to 15,6. The standard deviation ( $m^2$ ) equals 11,0. In other words,  $M \pm m^2$  corresponded to the value of  $120 \pm 11,0$  kg. To determine the indications for surgical treatment of patients with metabolic syndrome, obesity our paper shows calculation of body mass index (BMI). In the process of preparing the patient for surgery, it was found, that the average value of BMI observed in patients was 43 kg/ $m^2$ . The average statistical deviation (m) was equal to 5,0. Standard deviation ( $m^2$ ) equals 6,6. Thus  $M \pm m^2$  corresponded to the value of  $43 \pm 6, 6$  kg.

As seen from the statistics, the highest BMI, with which patients were operated, was 59,8 kg/ $m^2$ . The lowest 29,4 is registered for one patient aged 28 years. Performance standard deviation SD (Standard deviation) or deviations were not high or statistically significant, slightly different from the average deviation of **m and m<sup>2</sup>**. We can conclude from these statistical calculations, that the maximum weight of operated patients was 168 kg. The lowest weight, that is 80 kg recorded for one patient aged 21 years old. SD indicators (standard deviation or deviation) compared to age and weight also was not high or statistically significant. It differs little from the average deviation of **m and m<sup>2</sup>**, as in the previous comparison.

The results of patient's body weight measurement before the operation at the time of treatment of surgical treatment, after long and ineffective conservative treatments were plotted. Under visual analysis the sequence of events was determined

(angl.-case) with the order numbered 1, 2, 3 ... and so on. It revealed quite a large variation in body weight values of patients before surgery. For example: the first case of surveillance is 130 kg, the third is 98 kg, the seventeenth case is 80 kg. In other words, it can be argued that the method of statistical sampling in conducting scientific analysis in this paper is random. Consequently, the results of the calculations are more likely to reflect sufficiently reliable and very close to reality.

The age and weight dependence is stating correlations between these parameters. Given the calculation of statistical parameters Fisher gave the following correlation parameters:  $r = 0,5$ ;  $p = 0,002$ ; Fisher  $z = 0,549$ . At the same time, the Pearson correlation coefficient ( $r$ ) was  $-0,0594$ , indicating a very weak relation. Different picture of the surveyed patients with weight-dependent correlation and growth was regis-

tered. The correlation coefficient of the data values in all groups was higher. So, taking into account the statistical parameters of the Pearson correlation coefficient ( $r$ ) in these comparable figures was 0,3639, with an indication of multiple dependent values.

Thus, for a fair selection of patients with obesity and metabolic syndrome for bariatric surgery requires knowledge of the anthropometric indicators for the given patients. In addition, the correlative links comparison between indicators of age, weight, body mass index, body weight and height must be executed, in order to identify the highest correlation coefficient.

---

The work is submitted to the International Scientific Conference «Homeostasis and infectious process», Israel (Tel Aviv), February, 20–27, 2016, came to the editorial office on 13.02.2016.

*Short Reports***PRIORITY TRENDS OF PREVENTION OF HIV INFECTION IN RUSSIAN PROVINCE (BY THE EXAMPLE OF STAVROPOL KRAI)**

Savchenko V.V., Kiseleva I.N.  
*Stavropol State Medical University,  
 Stavropol, e-mail: vellsav@mail.ru*

Spreading of HIV-infection represent a life danger, safety and welfare danger to the whole population, national wellbeing and security of Russia in general. Nowadays situation with HIV-infection in Russia characterizes by magnification in numbers, enlargement of infected people age distribution, increase of sexual transmission of the virus and rate of tuberculosis contamination combined with HIV-infection.

In 2015 epidemic situation of HIV-infection in Russia at the Stavropol territory (the same as in the whole Russia in general) didn't have stabilization signs and stayed arduous. Significant deterioration of epidemic situation is observed after the past 2 years. 752 HIV-infection cases revealed at the Stavropol territory in 2015, which is 62,4% greater than in 2014 and 3,1 times bigger than in 2013. Morbidity rate amounted to 26,6 on 100 000 people.

From the total amount of registered people – 79% of them are permanent residents of the city, 8% – homeless people, 7% – residents of another subjects of the Russian Federation, temporary staying at the Stavropol territory and 7% of foreign people. 58% of foreign people were the ones forced to leave Ukraine.

Mainly spreading of HIV typical to male part of the Stavropol territory population. Males compiled 68% of the total amount. The ratio of infected males and females is 2,2:1,0

The number of infected people from older age groups continued to grow in 2015. At the age of 30 to 39 revealed 42,2% (365 people), to compare – 43% (194 people) in 2014. The age group of 20 to 29 revealed 19,8% (147 people) to 26% (117 people) in 2014. Children younger than 14 revealed 0,4% (3 people) and youth from 15 to 20 – 1% (8 people).

Socially professional composition of HIV-infected people have been stable for a long lime and was characterized by involvement of socially adapted contingent. So at the period of 2013–2014 the majority of infected people were the working class – workers, employees, entrepreneurs, service workers etc. The condition have changed in 2015 – 62% of identified HIV infected were socially non-adapted – homeless people, prisoners

and unemployed people mainly due to increase of drug related infection.

It should be noted that for more than 10 years (including 2014) the main reason for HIV-infection at the Stavropol territory were heterosexual contacts. In 2014 57% were infected this way. Besides in 2015 the main way of infection was drug and psychoactive substances injection – 57,7% (418 people). At the same time the enhancement of the sexually infected people occurred – from 261 to 301 people, moreover, 11 patients were infected through the homosexual way. In general sexual way of spreading the infection was amounted to 41,9% in 2015. HIV infection of children got from their mothers during the pregnancy period, childbirth and breastfeeding .appeared in 0,4% cases (3 children).

After the registration of the first HIV-infection cases at the Russian Federation territory epidemic response system was created: sanitary-epidemic control system for the infectious diseases was mobilized, research and educational medical institutions operatively and scientifically highly skilled included this problem into their programs, medical workers of all specializations did proper training.

Along with that, the following factors negatively influence the successful solution of decreasing of infection spreading:

- Insufficient informing of population and infection risk groups by HIV-infection prophylactic programs.
- Low knowledge level, lack of motivation to safely behavior, healthcare and HIV testing.
- High level of discrimination of HIV-infected people.
- Insufficient use of potential of the social associations, religious organizations HIV-prophylactic.

For the purpose of reduction of HIV-infection for the Russian Federation population The Ministry of health of the Russian Federation created a governmental strategy project to resist spreading of the infection, caused by the human immunodeficiency virus (HIV) in the Russian Federation for the period until 2010. One of the main actions of this project is common access of the population to the effective measures preventing from spreading the HIV-infection.

Mainly HIV-infection concentrates among the social groups experiencing unusual and risky sexual relations, using injecting drugs which compile social category related to the “group of social risk” which means that it isn't covered by the systematic prophylactic work from the governmental municipal side.

In order to maintenance the effectiveness of prophylactic programs at such social groups and

supply the information of the ways of spreading HIV-infection, increase motivation of HIV testing involvement of volunteers and outreach workers is needed.

The most effective way to realize the prophylactic program is to attract volunteers who did the drug addiction rehabilitation course. They know well the drug addict life features and the need of taking drugs that helps to build high level of trust and involvement of the risk groups into prophylactic programs.

An experience in realization of the national and multinational HIV prophylactic programs testifies the leading role of outreach groups in infection risk reduction of the people practicing hazardous behavior. The conditions of successful outreach groups are: the presence of volunteers having special education, the time needed to make trustful relations with certain group of people, transport charges [1].

No less important guideline at the prophylactic work for HIV spreading prevention is teenagers and youth preparation in "equal to equal" programs, especially for the works in unfavorable youth groups – college students and young people practicing homosexual relations. Into the program composition of volunteer training must be included

not only informational blocks about the HIV epidemiology, ways and methods of infecting but also training approvals to stigma reduction in relation to people living with HIV.

Traditionally, prophylactic programs are oriented on teenagers and youth and are realized in educational institutions of different levels whereas HIV-infection is typical to older ages. At this connection it's necessary to activate the work in mass media and also in the Internet.

Thus, despite the measures taken during the recent years, tendency of HIV spreading requires further improvement in prophylactic work and increase of effectiveness in interagency cooperation of solving this problem.

#### References

1. Kuzembaeva K.K., Musina S.B., Momimbeckov E.T., Abdarkhmanov E.S. Introduction of volunteer action at work with the vulnerable population groups for prevention of HIV-infection // West Kazakhstan. – 2012. – № 35. – С. 184–185.
2. Governmental strategy of prevention of illness caused by the human immunodeficiency virus (HIV) in the Russian Federation during the period until 2020. [Internet resource]. – Access mode: <http://www.garant.ru/products/ipo/prime/doc/56560166>.
3. Epidemiology of HIV-infection. Stavropol State AIDS center. [Internet resource]. – Access mode: <https://skc-spид.ru/vse-o-vich-spид/352-epidemiologiya-vich-infektsii.html>.



## CHANGES IN THE REPRODUCTIVE SYSTEM OF RATS AND ITS GETS IN ANTENATAL PERIOD AFTER SESAME SEEDS OIL MEAL SUPPLEMENT

<sup>1</sup>Pavlova O.N., <sup>2</sup>Garipov T.V., <sup>1</sup>Pinaeva O.N., <sup>1</sup>Supilnikov A.A., <sup>3</sup>Yukhimets S.N.

<sup>1</sup>Private educational institution of higher education oborganizatsiya "Medical University" REAVIZ, Samara, e-mail: [casiopeya13@mail.ru](mailto:casiopeya13@mail.ru);

<sup>2</sup>SEI HPE "Kazan State Academy of Veterinary Medicine named after N.A. Bauman", Kazan;

<sup>3</sup>College of health sciences, The University of Dodoma, Dodoma

The article describes reactive changes in the reproductive system of rats after sesame seeds oil meal supplement. The experiment involved 80 female and 32 male rats one month of birth, weighing 190–210 g, equally divided into 8 groups. Animals were administered suspension of sesame seeds oil meal according to the group affiliation. Oil meal suspension was prepared on distilled water. The animals received suspension daily intragastrically at a dose of 10 mg/100 g body weight, 1 ml of volume, in accordance with the group affiliation and schedule. The control animals received 1 ml of distilled water. All animals were daily monitored. The following parameters were assessed depending on the duration of sesame seeds oil meal intake: embryonic (pre- and post-implantation) mortality; backwardness in a form of decreased body weight and cranio-caudal sizes of a fetus, as well as condition of the reproductive system in the males and in the females. The experiment revealed that additional supplement of sesame seeds oil meal causes gonadotropic effect: an increase of testes and prostate mass ratio in males, a decrease of pathological sperm cells number; the females demonstrated decreased number of the atretic bodies and increased number of Graafian follicles in the ovaries. Depending on the duration of the oil meal intake, the females showed an increase in the average number of the pups in a litter and an increase in the number of implantation sites per one female rat, a reduction of total embryonic mortality, fetal weight and cranio-caudal size, as well as placenta weight. In addition, the study showed decreased probability of hemorrhage in the fetal meninges and non-significantly increased probability of local bleeding, possibly due to hypercoagulability.

**Keywords:** sesame seeds oil meal, rats, reproductive system, pre-implantation mortality, post-implantation mortality, cranio-caudal sizes, fetal-placental index

All functional activity of the body is focused on the maintaining of the reproductive system and on the optimization of the birth process. Condition of the reproductive system is a direct reflection of the internal dynamic stability, as well as properties and stability of the basic physiological body functions.

For this system, the indicators of the normal activity include: mass ratios of the testes, parorchis, and prostate; sperm quality; number of the atretic bodies and Graafian follicles, follicles with a single granulosa cells layer, follicles with two or more granulosa cells layers.

The reproduction parameters include: number of the fetuses and the corpora lutea per female rat; pre-implantation embryonic mortality; post-implantation embryonic mortality; total mortality; average weight of a fetus; cranio-caudal sizes of a fetus; weight / length ratio of a fetus; average weight of placenta; fetal – placental index [5].

Administration of the biologically active substances, for example, sesame seeds oil meal, is one of the methods to correct the functionality of these systems.

Sesame seeds oil meal with its specific chemical composition is an optimal substitution for these purposes.

It contains saturated and polyunsaturated fatty acids, triglycerides and glyceryl esters, A, B, E, C, PP vitamins, affecting the blood composition, rate of growth, condition of the nervous and digestive systems [1, 2, 3, 4].

The oil meal contains different mineral components including calcium, phosphorus, iron, potassium, magnesium, making it ideal for bones and joints. Composition of the sesame seeds oil meal also includes phytin which helps to restore mineral body balance; among other components there are dietary fibers, lecithin and sesamin – an antioxidant which uses for lots of diseases, including cancer, and which is able to reduce blood cholesterol level.  $\beta$ -phytosterol, also found in the oil meal, has similar cholesterol reduction effect. Oil meal anti-inflammatory effect is associated with  $\beta$ -phytosterol which reduces the risk of atherosclerosis [1, 2, 3, 4].

Sesame seeds oil meal is a waste of food production, thus, it is cheaper raw material than whole sesame seeds or oil. That is why the oil meal is economically more interesting, as small concentrations of the active substrates is enough to achieve therapeutic effect [3].

Seeing that sesame seeds oil meal can be used to correct different pathological conditions and to maintain the homeostasis in a constantly changing environment, **the aim of this work** was to study the reproductive system in rats and its get in the antenatal period to determine possible biological effects of oil meal.

To achieve this aim, the following indicators had to be analyzed: embryonic (pre- and post-implantation) mortality depending on the duration of sesame seeds oil meal intake; backwardness in a form of decreased body weight

and decreased cranio-caudal sizes of a fetus, fetal-placental index, as well as condition of the males and females reproductive system.

### Materials and methods of research

The study included healthy mature outbred rats kept in a vivarium under standard conditions.

The study involved 80 females and 32 males one month of birth, weighing 190–210 g. The rats were equally divided into 8 groups (Table 1) and received suspension of sesame seeds oil meal in accordance with the group affiliation.

analyzed. Embryonic material was carefully examined with special attention to the anatomical structure of the fetuses, its weight and cranio-caudal sizes [5].

The signs of sesame seeds oil meal negative effects considered to be embryonic (pre- and post-implantation) mortality and backwardness in a form of decreased body weight and cranio-caudal sizes of the fetus.

Pre-implantation embryonic mortality was calculated as a difference between the number of the corpora lutea and the number of the implantation sites in the uterus.

Post-implantation mortality was calculated as a difference between the number of the implantation sites and the number of the alive fetuses.

**Table 1**

Groups of the experimental animals

Group number	Study materials
1	Suspension of sesame seeds oil meal was administered to the males and the females for 21 days before the fertilization.
2	Suspension of sesame seeds oil meal was administered to the females for 21 days before the fertilization; the males received distilled water.
3	Suspension of sesame seeds oil meal was administered to the males for 21 days before the fertilization; the females received distilled water.
4	Suspension of sesame seeds oil meal was administered to the females for 21 days before pregnancy, as well as from the 1 <sup>st</sup> to the 13 <sup>th</sup> day of pregnancy.
5	Suspension of sesame seeds oil meal was administered to the females for 21 days before pregnancy, as well as from the 14 <sup>th</sup> to the 20 <sup>th</sup> day of pregnancy.
6	Suspension of sesame seeds oil meal was administered to the females from the 1 <sup>st</sup> to the 13 <sup>th</sup> day of pregnancy.
7	Suspension of sesame seeds oil meal was administered to the females from the 14 <sup>th</sup> to the 20 <sup>th</sup> day of pregnancy.
8	Control group of animals
9	Suspension of sesame seeds oil meal was administered to the males for 41 days.

Suspension of sesame seeds oil meal was prepared on distilled water. The animals received suspension on daily basis intragastrically at a dose of 10 mg/100 g body weight, 1 ml of volume, in accordance with the group affiliation and schedule. The control animals received 1 ml of distilled water. All animals were strictly monitored.

In order the females to have known date gestation, the researchers used 4–4,5 months rats. The males (1 male per 2–3 females) were brought to the females in the evening, and in the morning the females were taken the vaginal smears. Since rats usually have breeding in 1–2 am, the day of sperm detection in the smear was considered as the first pregnancy day. After that the males were taken from the females. Pregnant rats were kept in the individual cages with bedding necessary for making a nest. The animals were monitored from the first pregnancy day. The researchers registered females' condition and behavior, the dynamics of the body weight, duration of pregnancy and the process of labor.

The study results were analyzed after the pregnant females were killed by cervical dislocation on 20<sup>th</sup> pregnancy day. The following parameters were examined at autopsy: number of the corpora lutea in the ovaries, number of the implantation site in the uterus, number of alive and dead fetuses. Condition of the placenta was also

Other assessed parameters included the overall embryonic mortality, litter size, number of the alive fetuses [5].

Digital material was statistically analyzed with Student's t-test using the program Sigma Stat 6.0 [5].

### Results of research and their discussion

During the entire pregnancy, no significant differences in the dynamics of the body weight in the pregnant rats were revealed between the experimental and the control groups (Table 2).

Table 3 shows the results of the reproductive function quantitative assessment in rats and its gets in antenatal period after sesame seeds oil meal supplement.

The results presented in the Table 3 shows that only in the 7<sup>th</sup> experimental group the average number of the pups in a litter corresponded to a level observed in the control group, while in the other groups the average number of the pups was significantly greater: 22,4% more in the 1<sup>st</sup> group, 26,2% more in the 2<sup>nd</sup> group, 18,7% more in the 3<sup>rd</sup> group, 31,8% more in the 4<sup>th</sup> group, 24,3% more in the 5<sup>th</sup> group and 13,1% more in the 6<sup>th</sup> group.

Table 2

History of body weight in pregnant rats

Gestation age	Animals group							
	1	2	3	4	5	6	7	8
Before the study	209,6±8,17	197,1±7,29	205,5±6,98	192,8±7,52	201,3±7,85	213,4±6,62	202,2±6,67	208,7±7,51
7 days	245,6±7,85	247,1±7,17	229,9±8,05	231,8±8,34	232,3±7,20	246,4±9,36	229,1±7,10	237,3±7,59
14 days	281,6±10,14	284,3±11,09	257,9±8,78	272,5±10,08	265,3±8,22	283,4±10,20	252,1±8,32	268,7±9,14
20 days	310,6±9,94	316,3±11,07	289,1±9,54	309,2±9,59	304,7±10,06	306,3±9,80	288,6±10,68	301,6±10,56

Table 3

The reproductive system of rats and its gets in antenatal period after sesame seeds oil meal supplement

Indicators		Control group (8)	Experimental groups received sesame seeds oil meal						
			1	2	3	4	5	6	7
Number of	Female rats	10	10	10	10	10	10	10	10
	Fetuses / per one female rat	10,7±0,38	13,1±0,41 <sup>1</sup>	13,5±0,45 <sup>1</sup>	12,7±0,37 <sup>1</sup>	14,1±0,39 <sup>1</sup>	13,3±0,47 <sup>1</sup>	12,1±0,43 <sup>1</sup>	11,2±0,37
	Corpora lutea / per one female rat	13,8±0,44	15,1±0,49	14,9±0,54	14,3±0,36	16,7±0,57 <sup>1</sup>	15,5±0,51 <sup>1</sup>	13,9±0,43	13,1±0,46
	Implantation sites / per one female rat	11,1±0,35	13,3±0,44 <sup>1</sup>	13,8±0,39 <sup>1</sup>	12,9±0,45	15,7±0,46 <sup>1</sup>	14,2±0,41 <sup>1</sup>	12,5±0,41 <sup>1</sup>	11,9±0,32
Pre-implantation embryonic mortality	Absolute number	2,7±0,08	1,8±0,06 <sup>1</sup>	1,1±0,07 <sup>1</sup>	2,2±0,07 <sup>1</sup>	1,0±0,04 <sup>1</sup>	1,3±0,05 <sup>1</sup>	1,4±0,05 <sup>1</sup>	1,2±0,08 <sup>1</sup>
Post-implantation embryonic mortality	Absolute number	0,4±0,012	0,2±0,006 <sup>1</sup>	0,3±0,009 <sup>1</sup>	0,2±0,005 <sup>1</sup>	1,6±0,051 <sup>1</sup>	0,9±0,032 <sup>1</sup>	0,4±0,013	0,7±0,020 <sup>1</sup>
Total mortality	Absolute number	3,1±0,08	2,0±0,07 <sup>1</sup>	1,4±0,04 <sup>1</sup>	2,4±0,08 <sup>1</sup>	2,6±0,09 <sup>1</sup>	2,2±0,08 <sup>1</sup>	1,8±0,06 <sup>1</sup>	1,9±0,07 <sup>1</sup>
Average fetal body weight, g	20 <sup>th</sup> day of the embryonic development	1,37±0,046	1,62±0,053 <sup>1</sup>	1,58±0,046 <sup>1</sup>	1,35±0,038	1,61±0,047 <sup>1</sup>	1,55±0,060 <sup>1</sup>	1,48±0,052	1,51±0,051
Cranio-caudal sizes of a fetus, cm		2,62±0,091	3,03±0,085 <sup>1</sup>	3,10±0,099 <sup>1</sup>	2,81±0,101	3,14±0,097 <sup>1</sup>	3,09±0,108 <sup>1</sup>	2,65±0,098	2,70±0,086
Weight / length ratio of a fetus		0,52±0,017	0,53±0,015	0,51±0,018	0,48±0,013	0,51±0,017	0,50±0,016	0,56±0,021	0,56±0,016
Average weight of placenta, g	Fetal-placental index	0,38±0,013	0,43±0,012 <sup>1</sup>	0,41±0,013	0,34±0,011 <sup>1</sup>	0,49±0,018 <sup>1</sup>	0,47±0,015 <sup>1</sup>	0,38±0,011	0,40±0,012
Fetal – placental index		0,27±0,009	0,27±0,007	0,26±0,008	0,25±0,008	0,30±0,008 <sup>1</sup>	0,30±0,007 <sup>1</sup>	0,26±0,011	0,26±0,010
Results of the fetuses visual examination									
Number of the examined fetuses	Absolute number	113	137	142	124	149	126	118	110
Number of the fetuses with malformations	Total number / %	3 / 2,6	0	0	1 / 0,8	0	2 / 1,6	2 / 1,7	0
Results of the internal organs examination in the fetuses									
Number of the examined fetuses	Absolute number	113	137	142	124	149	126	118	110
Number of the fetuses with malformations	Total number / %	7 / 6,1	0	1 / 0,7	2 / 1,6	0	1 / 0,8	3 / 2,5	0
Results of the skeletal development examination in fetuses after sesame seeds oil meal supplement									
Number of the examined fetuses	Absolute number	113	137	142	124	149	126	118	110
Breastbone ossification delay	Total number / %	0	0	0	0	0	0	0	1 / 0,9
Hyoid bone ossification delay	Total number / %	2 / 1,7	0	0	2 / 1,6	0	0	2 / 1,7	0
Metacarpal and metatarsal bones ossification delay	Total number / %	0	0	1 / 0,7	0	0	1 / 0,8	1 / 0,8	0
Diamelia	Total number / %	0	0	0	0	0	0	0	0

Note. The differences are significant for P < 0,05: <sup>1</sup> – as compared to the control group of animals.

In the 1<sup>st</sup>, 2<sup>nd</sup>, 3<sup>rd</sup>, 6<sup>th</sup> and 7<sup>th</sup> experimental groups, the number of the corpora lutea per one female was about the same and corresponded to the level in the control group. Herewith, in the 4<sup>th</sup> group, the average number of the corpora lutea per one female was 21,0% more and in the 5<sup>th</sup> group – 12,3% more than in the control group.

In the 3<sup>rd</sup> and 7<sup>th</sup> groups, the number of the implantation sites per one female corresponded to the level in the control group, while in the 1<sup>st</sup>, 2<sup>nd</sup>, 4<sup>th</sup>, 5<sup>th</sup>, and 6<sup>th</sup> groups it was more than in the control group on 19,82%, 24,32%, 41,44%, 27,93%, and 12,62% respectively.

In all experimental groups, pre-implantation embryonic mortality was significantly less than in the control group: 33,33% less in the 1<sup>st</sup> group, 59,26% less in the 2<sup>nd</sup>, 18,52% less in the 3<sup>rd</sup>, 62,96% less in the 4<sup>th</sup>, 51,85% less in the 5<sup>th</sup>, 48,15% less in the 6<sup>th</sup> and 55,56% less in the 7<sup>th</sup> group.

In the 6<sup>th</sup> experimental group, post-implantation embryonic mortality corresponded to the level of the control group. In the 1<sup>st</sup> and 3<sup>rd</sup> groups, it was 50% less than in the control one, while in the 2<sup>nd</sup> experimental group it was 25% less. In the 4<sup>th</sup>, 5<sup>th</sup> and 7<sup>th</sup> experimental groups, post-implantation embryonic mortality was 300, 125 and 75% more than the control group respectively.

Thus, the overall embryonic mortality in all the experimental groups was significantly less than in the control group: in the first group it was 35,48% less, in the second – 54,84% less, in the third – 22,59% less, in the fourth – 16,13% less, in the fifth – 29,03% less, in the 6<sup>th</sup> – 41,94% less, and in the 7<sup>th</sup> group it was 38,71% less than in the control group.

The average weight of the fetuses in the 3<sup>rd</sup>, 6<sup>th</sup> and 7<sup>th</sup> groups almost did not differ from the control level. In other experimental groups, the average weight of the fetuses was significantly more than the control group: in the 1<sup>st</sup> group – 18,3% more, in the 2<sup>nd</sup> – 15,3% more, in 4<sup>th</sup> group – 17,5% more, and in the 5<sup>th</sup> group – 13,1% more than in the control group.

Cranio-caudal size of the fetuses in the 3<sup>rd</sup>, 6<sup>th</sup> and 7<sup>th</sup> groups corresponded to the control level, and in the 1<sup>st</sup>, 2<sup>nd</sup>, 4<sup>th</sup> and 5<sup>th</sup> groups it was significantly more than in the control group – on 15,6; 18,3; 19,8% and 12,6%, respectively.

In all groups, the weight / length ratio of the fetuses was approximately the same and corresponded to the control level.

In the 2<sup>nd</sup>, 6<sup>th</sup> and 7<sup>th</sup> groups, the average weight of the placenta corresponded to the control level. In the 1<sup>st</sup>, 4<sup>th</sup> and 5<sup>th</sup> groups, placenta weighted 13,2; 28,9 and 23,7% more respectively than in the control group, and in the 3<sup>rd</sup> group, it was 10,5% less than in the control group.

In all the experimental groups, except for the 4<sup>th</sup> group, the fetal-placental index was approximately the same and matched the control. In the 4<sup>th</sup> group, it was 11,1% more than the control.

Visual examination showed no malformations in the 1<sup>st</sup>, 2<sup>nd</sup>, 4<sup>th</sup> and 7<sup>th</sup> groups. Herewith, there were 3 pups with malformations (2,6%) in the control group, 1 pup in the 3<sup>rd</sup> group (0,8%), 2 pups in the 5<sup>th</sup> group (1,6%) and 2 pups in the 6<sup>th</sup> group (1,7%).

The results of the fetuses' internal organs examination revealed malformations in 7 pups (6,1%) from the control group, in 1 pup from the 2<sup>nd</sup> and 1 pup from the 5<sup>th</sup> group (0,7 and 0,8%), in 2 pups from the 3<sup>rd</sup> group (1,6%), and in 3 pups from the 6<sup>th</sup> group (2,5%).

The results of the fetuses' skeletal system examination after sesame seeds oil meal supplement revealed breastbone ossification delay in 1 pup (0,9%) from the 7<sup>th</sup> experimental group.

Hyoid bone ossification delay was registered in 2 pups from the control group (1,7%), as well as in the 3<sup>rd</sup> and 6<sup>th</sup> experimental groups (1,6 and 1,7% respectively). Metacarpal and metatarsal bones ossification delay was revealed in 1 fetus from the 2<sup>nd</sup>, 5<sup>th</sup> and 6<sup>th</sup> experimental groups (0,7; 0,8 and 0,8%, respectively). No diamelia was found.

The results of the internal organs examination showed 1 pup (0,8%) with vascular congestion in the liver in the 6<sup>th</sup> group. Hemorrhages in the liver were found in 1 fetus (0,8%) from the 3<sup>rd</sup> group. Subcutaneous hemorrhages were revealed in 1 fetus from the 2<sup>nd</sup> and 6<sup>th</sup> groups (0,7 and 0,8% respectively). Hemorrhages in the kidneys were revealed in 1 fetus (0,8%) from the 6<sup>th</sup> experimental group. Hemorrhages in the intestine and stomach were registered in 1 fetus (0,8%) from the 3<sup>rd</sup> and from the 5<sup>th</sup> groups. Hemorrhages in the meninges were revealed in 7 fetuses (6,1%) from the control group.

The results of the reproductive system assessment in the males showed (Table 5), that testes mass ratio in the 1<sup>st</sup> experimental group was similar to the control group, while in the 9<sup>th</sup> group, it was significantly higher (on 10,6%). In the experimental groups, the parorchis mass ratio did not differ from the control level. The prostate gland mass ratio in the 9<sup>th</sup> experimental group was 12,1% more than the control group, and in the 1<sup>st</sup> group it was equal to the control. In rats received sesame seeds oil meal, a number of the abnormal sperm cells were less than in the control group (on 19,4% in the 1<sup>st</sup> experimental group and on 16,0% in the 9<sup>th</sup> group).

**Table 5**  
Functional condition of the testes in rats after sesame seeds oil meal supplement

Indicators	The control group (8)	The groups received sesame seeds oil meal	
		1	9
Testes mass ratio	8,5 ± 0,29	8,7 ± 0,27	9,4 ± 0,31 <sup>1</sup>
Parorchis mass ratio	3,9 ± 0,13	4,3 ± 0,15	4,2 ± 0,14
Prostate gland mass ratio	3,3 ± 0,12	3,3 ± 0,10	3,7 ± 0,13 <sup>1</sup>
Pathological forms of the sperm cells, %	38,7 ± 1,35	31,2 ± 1,06 <sup>1</sup>	32,5 ± 1,14 <sup>1</sup>

Note. In this table the differences are significant for  $P < 0,05$ : <sup>1</sup> – as compared to the control group of animals.

**Table 6**  
The results of the ovarian structures quantitative assessment after sesame seeds oil meal supplement

Ovarian structures	The control group (8)	The 1 <sup>st</sup> group
Atretic bodies in the ovaries	1193,5 ± 42,93	947,4 ± 32,21 <sup>1</sup>
Graafian follicles	6,5 ± 0,21	7,7 ± 0,24 <sup>1</sup>
Follicles with a single granulosa cells layer	657,8 ± 24,95	629,9 ± 17,55
Follicles with two and more granulosa cells layers	82,3 ± 2,72	106,2 ± 3,82 <sup>1</sup>

Note. In this table the differences are significant for  $P < 0,05$ : <sup>1</sup> – as compared to the control group of animals.

The results of the reproductive system assessment in the females showed (table 6), that in the 1<sup>st</sup> experimental group, number of the atretic bodies in the ovaries was 20,6% less than in the control group; number of the Graafian follicles was 18,5% more as compared with the control level; number of the follicles with two or more granulosa cells layers was 29,0% more. However, number of the follicles with a single granulosa cells layer was 4,2% less as compared with the control group.

Thus, based on the study results the following conclusions can be made:

– sesame seeds oil meal supplement causes gonadotropic effect: an increase of the testes and prostate gland mass ratio, a decrease of the pathological sperm cells in males, a decrease of the atretic bodies in the ovaries and an increase of the mature follicles.

– depending on the duration of the oil meal intake by the females, the average number of the pups per litter and the implantation sites per female increases;

– after sesame seeds oil meal supplement, overall embryonic mortality decreases, weight and

cranio-caudal size of the fetuses increases, as well as the average weight of the placenta; probability of the hemorrhages in the meninges decreases, but the probability of local bleeding increases, possibly due to increased blood coagulation.

#### References

1. Biktulov L.N., Gerasimov Yu.L., Purygin P.P. Pervushkin S.V. Study of sesame seeds oil meal toxicity to develop a dietary supplements // The Samara Scientific Center of the Russian Academy of Sciences News. – 2009. – Vol. 11, № 1 (5).
2. Kurkin A.V. Flavonoids as a promising source of eco-protectors // Ecology and Human Health: Proceedings of the XI Russian National Congress: “The problems of human survival in the technological environment of modern cities” December 5–7, 2006. – Samara, 2006. – P. 159–160.
3. Pavlova O.N. Analysis of blood morphological composition in rats after intragastric administration of grape, pomegranate and sesame seed oil meal // Bulletin of the Samara State Academy of Agriculture. – Samara, 2012. – № 1. – P. 43–47.
4. Pavlova O.N., Grigorieva Y.V. Histomorphological characteristics of liver tissue and blood morphological composition in rats after sesame seeds oil meal administration // Bulletin of “REAVIZ” Medical Institute: Rehabilitation, Doctor and Health. – Samara, 2012. – № 2 (6). – P. 65–73.
5. Guidelines for experimental (preclinical) study of the new pharmacological agents / under Habriev R.U. editorship – second revised and enlarged edition. – M.: Medicine, 2005. – P. 832.

## Short Reports

**THE RESERCH OF QUANTITATIVE  
CONTENT OF ORGANIC ACID  
IN MULTIVITAMIN PLANT COLLECTION**

<sup>1</sup>Marakhova A.I., <sup>2</sup>Sergunova E.V.,  
<sup>1</sup>Stanishevskiy Ya.M.

<sup>1</sup>Peoples Friendship University of Russia,  
Moscow, e-mail: agentcat85@mail.ru;

<sup>2</sup>I.M. Sechenov First Moscow State Medicinal  
University, Moscow

The article presents the results of a quantitative analysis of organic acids in the multivitamin plant collection № 2. The authors have developed a method of potentiometric titration of the amount of organic acids and ascorbic acid. The results are compared with the data of the indicator and coulometry titration. The advantage of using a potentiometer to more accurately establish the endpoint is proved.

Currently vitamin preparations are very popular. Vitamins are present in large amounts in the medicinal plant raw materials (PRM), predominantly accumulated in fruits. Plant vitamins are better absorbed by organism than synthetic analogs [1].

Multivitamin plant collection № 2 consists of fructus Rosae and fructus Sorbi in equal proportions. It is a source of vitamins such as K, B<sub>2</sub>, P, carotenoids. Some of them, such as ascorbic acid, pass into infusion. A second hydrophilic group of compounds of the collection are organic acids [1]. They are involved in the metabolic processes, in the Krebs cycle, raise the tone. Quality score pH value of remedies with acidic reaction is important, because it is contraindicated to patients with gastritis and peptic ulcer gastrointestinal tract [1, 2].

In Russia, the quality of multivitamin collection № 2 regulated by normative document ND-42-0426382103, has not changed since 2004 [3]. It is clear that the documents requires a revision because of the development of the instrumental base and increase the quality requirements of drugs.

Standardizing of the Multivitamin plant collection № 2 is logical to carry out on compounds constituting the hydrophilic fraction and predominantly in the raw material, such as ascorbic acid and

the sum of organic acids. Modern physico-chemical methods should be used for this purpose [2].

In connection with the above, purpose of the study was the quantitative determination of the amount of organic acid and ascorbic acid in the multivitamin plant collection № 2 and its components by different physico-chemical methods.

**Materials and methods of research.** The objects of study were industrial samples of fructus Rosae and fructus Sorbi, multivitamin plant collection № 2 and the infusion prepared from it. Infusion prepared in accordance with the general pharmacopoeial article «Infusions and decoctions» of Russian Pharmacopoeia (RP) XI Ed., Vol. 2, P. 147–148.

Determination of pH of aqueous extracts was performed using the pH meter Seven Excellence™ (METTLER TOLEDO). Quantitative determination of the amount of organic acids and ascorbic acid were carried out by titration using indicators according to the procedure provided in Article 38 of the private pharmacopoeial article «Fructus» RP XI Ed., Vol. 2, P. 294–297 and [4]. Determination of free organic acid by potentiometric titration was performed using the pH meter Seven Excellence™ (METTLER TOLEDO). Determination of the amount of organic acids was carried out by coulometric titration using the device, «Expert-006» at a current of 5 mA.

**Results of research and their discussion**

**Quantitative determination of ascorbic acid.**

The results of the content of ascorbic acid in the multivitamin collection and its components obtained by titration with sodium 2,6 – dichlorphenolindophenol (2,6-DCPIP Na) and titration by potassium iodate are presented in Table 1.

Data in table 1 shows the convergence of the results obtained by different methods. Therefore, the amount of ascorbic acid in the multivitamin plant collection № 2 and its components may be determined by titration by potassium iodate.

**Quantitative determination of the amount of free organic acids.** Potentiometric titration of the amount of organic acids was carried out by the following procedure.

**Table 1**

Content of the amount of ascorbic acid in the multivitamin plant collection № 2 and its components ( $n = 5$ ;  $p = 0,95$ )

Herbal raw material	Fructus Rosae	Fructus Sorbi	Multivitamin collection № 2
titration with 2,6-DCPIP Na	0,20 ± 0,01 %	0,23 ± 0,01 %	0,20 ± 0,01 %
titration by KIO <sub>3</sub>	0,18 ± 0,04 %	0,21 ± 0,01 %	0,18 ± 0,04 %

Table 2

The summary content of organic acids in terms to malic acid in the multivitamin plant collection № 2 and its components ( $n = 5$ ;  $p = 0,95$ )

Method	Analyzing object	The summery content of organic acids, %
Titration with indicators	Fructus Rosae	2,87 ± 0,01
	Fructus Sorbi	3,78 ± 0,02
	Multivitamin plant collection № 2	3,06 ± 0,02
Potentiometric titration	Fructus Rosae	2,79 ± 0,02
	Fructus Sorbi	3,68 ± 0,08
	Multivitamin plant collection № 2	3,01 ± 0,06
Coulometric titration	Fructus Rosae	2,60 ± 0,05
	Fructus Sorbi	3,59 ± 0,07
	Multivitamin plant collection № 2	3,15 ± 0,08

About 25 grams (accurately weighed) of raw material, milled to a particle size passing through a sieve with openings of 2 mm diameter were placed in a 250 ml flask, was poured 200 ml of purified water and allowed to stand for 2 hours on a boiling water bath under backflow condenser. Then extraction was cooled, filtered, transferred to a volumetric flask of 250 ml. The volume of extract was adjusted to the mark with water and mixed (solution A). By the pipette were measured 25 ml of solution A in a measuring cup, dropped a glass and silver chloride electrodes are connected to the appropriate terminals on ionometer. The solution titrated by 0,1 M sodium hydroxide solution using a microburette with constant stirring. Fixed pH values. According to the results of the titration curves were constructed in coordinates  $pH = f(V)$  for the determination of the equivalence point. For more accurate determination of the equivalent volume constructed differential titration curves in the coordinates  $dpH/dV = f(V)$ . Calculation carried by the formula:

$$X = \frac{V \cdot 0,0067 \cdot K \cdot 250 \cdot 100 \cdot 100}{V_a \cdot m \cdot (100 - W)},$$

where 0,0067 – amount of malic acid of 1 ml of sodium hydroxide (0,1 mol/l) in grams;  $V$  – the volume of sodium hydroxide solution (0,1 mol/L) was spent on titration in ml;  $K$  – correction factor;  $V_a$  – the amount of extract taken for titration, in ml;  $m$  – mass of raw material, in grams;  $W$  – loss on drying, in percent; 250 – volume of the extract, in ml.

Integral and differential curves of organic acids titration in infusion of the multivitamin collection is presented in Figure 1 and 2, respectively.

Coulometric titration is carried out by the following procedure. 50 ml of electrolyte solution (100 ml of saturated  $K_2SO_4$  solution was adjusted with purified water to a volume of 800 ml (ratio 1:7)) were measured to beaker. After generation of hydroxide ions introduced pipetted aliquot of solution A ( $V_a = 0,5$  ml). Titration was performed by hydroxide ions generated at the electrode. The percent

content of free organic acid reference to the malic acid ( $X$ ) in absolutely dry raw material was calculated by the formula:

$$X = \frac{x \cdot 10^{-6} \cdot 250 \cdot 100 \cdot 100}{V_a \cdot m \cdot (100 - W)},$$

where  $x$  – coulometer indications, the content of organic acids in referens to malic acid in micrograms;  $V_a$  – the amount of extract taken for titration, in ml;  $m$  – mass of raw material, in grams;  $W$  – loss on drying, in percent; 250 – volume of the extract, in ml.

Results of the quantitative determination of organic acids sum in the multivitamin plant collection № 2 and its components obtained by different methods are presented in the Table. 2.

The data in Table 2 show the comparability of the results obtained by potentiometric, coulometric titration, and titration with the indicator. Potentiometry and coulometry can be used for standartisation of the multivitamin plant collection № 2 and its components. Using of indicators can lead to errors in determining the endpoint because of its visual assessment.

### Conclusion

The possibility of ascorbic acid titration in multivitamin plant collection and its components by potassium iodate is showed. A potentiometric and coulometric titration method for summery determination of organic acids was developed. It was shown the advantage of instrumental methods over the titration using the indicator.

### References

1. Sergunova E.V., Samylina I.A., Sorokina A.A. Research about standardization of plant compositions with fructus Rosae // Farmacia. – 2004. – P. 16–17.
2. Marakhova A.I. The use of physical and chemical methods in the analysis of raw medicinal plants of the family Lamiaceae // PHD diss. – Perm, 2009. – 24 p.
3. Pharmacopeia USSR: Ed. 2. General methods of analysis. Herbal raw materials // MH USSR. – 11-th ed. – Moscow: Medicine. 1987. – 400 p.
4. Hudhes Davi Emlyn. Titrometric determination of ascorbic acid with 2,6-dichlorophenolindophenol in commercial liquid diets // J. Pharm. Sci. – 1983. – Vol. 72. – P. 29–34.

### NET PRIMARY PRODUCTION OF DRY STEPPES OF TYVA REPUBLIC

Sambuu A.D., Kirova N.A.

*Tuvian Institute for the Exploration of Natural  
Resources SB RAS, Kyzyl;  
Tuvian State University, Kyzyl,  
e-mail: sambuu@mail.ru*

Grassland resources are important on a world-wide basis. Intensified grazing is one of the main causes of ecological change of meadows and steppes. Almost all steppes are grazed and represent different stages of succession. Heavy grazing impact generally initiates a retrogressive succession (degradation) including a decrease in above-ground net primary production and phytomass as well as a change in species composition, especially in dominant structure. Removal of grazing pressure leads to a progressive succession with an increase in phytomass and production and replacement of degraded pasture community by the original plant association. Stocking rate is one of the most important factors affected a stage of pasture succession. At the

steppes, *C. leucophloea* – mainly in semidesert and desert steppes. Peculiar feature of Central Asia plant cover is the abundance of herb-bunch steppes dominated by *Filifolium sibiricum* and rhizome-grass steppes dominated by *Leymus chinensis*.

In Tuva winter pastures were supplied with pump-houses to provide a livestock with water. After collective farm disruption these pump-houses were demolished and pastures were left without water. Many winter pastures were abandoned and herdsman have driven their flocks into river valleys. Many summer pastures transformed into full year ones with heavy grazing impact. Change of stocking rate leads to degradational or restorational succession which can be observed and investigated then and there [6].

#### Materials and methods of research

The study was carried in geographical region of Central Asia – in the Uvsu-Nur depression of Tuva, that located in the southern part of Tuva on the boundary with Mongolia. In Tuva were investigated dry steppes with different grazing impact (Table 1).

**Table 1**

Description of the site investigated

Region	Coordinates	Altitude, m	Ecosystem type	Ann. prec (mm)	Ann. temp. (°C)
Tuva	49°40'N 95°03'E	1100	Dry steppes	150–170	–4,5

same time stocking rate is a powerful management tool allowing to regulate the amount of herbage available to animals [1, 2, 3].

In this study we were particularly interested in comparing some phytomass properties and species composition of the plant communities at different intensities of grazing impact of Tuva dry steppe vegetation.

Tuva (Russia) steppes belong to Central Asia (C.A.) subregion of steppe region of Eurasia [4]. In C.A. steppe communities feather-grasses from section *Leiostipa* (*S. krylovii*, *S. baicalensis*, *S. grandis*) dominate and on the West of the subregion *S. capillata* and *S. sareptana* prevail. Desert steppes are dominated by lowfeather-grasses from section Smirnova (*S. gobica*, *S. glareosa*, *S. klemenzii*). Among small-bunch grasses in true and dry steppes dominate *Cleistogenes squarrosa*, *C. songorica*, *Agropyron cristatum*, *Koeleria cristata*, *K. macrantha*, *K. altaica*, *Poa attenuata*, *P. botryoides*. Species of *Festuca* (*F. lenensis*, *F. kryloviana*, *F. valesiaca*) are found only in the mountain steppes.

Semishrubs from section *Artemisia* (*A. frigida*, *A. xerophytica*, *A. caespitosa*) are common to a wide variety of steppes. Under grazing impact *A. frigida* abundance usually increases. Steppe shrubs from genus *Caragana* (*C. microphylla*, *C. pygmaea*, *C. stenophylla*) occur in true and dry

Annual precipitation in Tuva steppes varies from 150 to 170 mm. The seasonal distribution of precipitation is rather constant: 70–80 % of the annual total falls during the warm half of the year. The yearly mean temperature at Erzin is –4,5 °C. The coldest month is January with a mean temperature of –33 °C. July is the warmest month with 22,0 °C. The growing season, i.e. the period over which the daily mean temperature remains above + 10 °C, lasts 130–140 days and the period with temperature above 0 °C – 180–190 days. The potential evapotranspiration for the growing season is about four – five times higher than the annual precipitation due to the high wind speed and a lot of very hot days with  $t^{\circ}$  above 30 °C. The steppes of Uvsu-Nur depression belong to the ultracontinental grassland type [6].

#### Results of research and their discussion

The following variables of the plant biomass structure are used [7]. *G* = above-ground green biomass; *D* = standing dead plant biomass (attached dead); *L* = litter; *R* = living roots; *Rh* = living rhizomes; *B* = *R* + *Rh* living below-ground organs; *V* = dead below-ground plant biomass; *B* + *V* = total below-ground plant biomass; *NPP* = net primary production; *ANP* = above-ground net primary production; *BNP* = below-ground net primary production.



*Field methods*

In Tuva at each site an area of 100×50 m was marked, within which the species composition was recorded in July in each of ten 10×10 m quadrates. For other measurements a series of ten 50×50 cm quadrates was located at random for each sampling occasion. The vegetation was clipped at the soil surface and the litter was collected. The above-ground plants biomass was sorted into green biomass per species and total standing dead biomass. Litter and lichens, if present, were washed on a sieve to remove soil particles.

Soil monoliths with a surface area of 100 cm<sup>2</sup> and a depth of 10 cm were collected in each quadrate to a depth of 20 cm. The monoliths were washed and the plant material collected on a 0,25 mm sieve. All above-ground and below-ground plant biomass was dried for 24 h at 80 °C and weighed. Below-ground plant material was sieved to separate the fraction with the length > 2 cm. From this fraction stem basis, rhizomes and long roots were selected [5].

From each sample certain portions of long roots (> 2 cm) and short roots (< 2 cm) were taken to divide plant material of both fractions into living roots and dead mass. The large fraction was divided according to the appearance of roots. Living roots are far more resilient than dead ones and are not so easily broken if twisted.

Net primary production (NPP) was calculated as the sum of the above-ground production (ANP) and below-ground production (BNP). ANP and BNP were estimated using balance equations.

For above-ground plant biomass we have:

$$\Delta G_n = G_{n+1} - G_n + \Delta D_n; \quad (1)$$

$$\Delta D_n = D_{n+1} - D_n + \Delta L_n; \quad (2)$$

$$\Delta L_n = L_{n+1} - L_n + \Delta M_n. \quad (3)$$

For below-ground plant biomass we have:

$$\Delta B_n = B_{n+1} - B_n + \Delta V_n; \quad (4)$$

$$\Delta V_n = V_{n+1} - V_n + \Delta W_n, \quad (5)$$

where  $G_n$ ,  $D_n$ ,  $L_n$ ,  $B_n$  and  $V_n$  are green biomass, standing dead, litter, living below-ground organs, and below-ground dead mass of the sample at occasion  $n$  respectively, and  $G_{n+1}$  etc. are the same variables at sampling occasion  $n + 1$ ;  $\Delta G_n$  is the green biomass production,  $\Delta D_n$  the standing dead production,  $\Delta L_n$  the litter production,  $\Delta M_n$  the litter mineralization;  $\Delta B_n$ , and  $\Delta V_n$  are the below-ground living and dead mass production respectively, and  $\Delta W_n$  the below-ground deadmass mineralization, all for the period between sampling occasions  $n$  and  $n + 1$ . Further we have:

$$ANP = \sum_{n=1}^N \Delta G_n; \quad (6)$$

$$BNP = \sum_{n=1}^N \Delta B_n, \quad (7)$$

where  $ANP$  and  $BNP$  are the annual above-ground and below-ground production calculated over  $N$  sampling occasions during a year.

For each period one of the increments  $\Delta G_n$ ,  $\Delta D_n$ ,  $\Delta L_n$ ,  $\Delta M_n$  and one of the increments  $\Delta B_n$ ,  $\Delta V_n$ ,  $\Delta W_n$  must be taken as zero, according to the rule following from the «minimal production estimation» method [7].

**Net primary production**

Net primary production was calculated for three years in moderately grazed steppe and for one season in overgrazed and recovering steppes (Table 2).

**Table 2**

Net primary production in steppes, g/m<sup>2</sup> dw.  
Below-ground production for 0–20 cm soil layer.

OG – overgrazed, MG – moderately grazed,  
LG-1 = lightly grazed for 1 year,  
LG-4 = lightly grazed for 4 years

Production	OG	MG			LG-1	LG-4
	2010	2012	2013	2014	2013	2014
Above-ground	78	85	284	215	75	107
Below-ground	627	497	1419	1935	348	2025
Total	705	582	1703	2150	423	2132

The NPP of moderately grazed steppe varies during three years from 284 to 1419 g/m<sup>2</sup> per year in dependent on weather conditions. The growing seasons in 2012 and 2014 were normally warm and dry while summer in 2012 was very hot and dry. The NPP value in 2013 and 2014 was very high (1703–2150 g/m<sup>2</sup>). In this very dry season production process was not influenced by the grazing regime. Plants in overgrazed, moderately grazed and recovering for one year pastures produced modest quantity of biomass, moreover NPP is highest in overgrazed steppe. By the end of the fourth year of recovery a burst in the development of the community occurred. Shoots, rhizomes and roots of all species represented in the community had increased. An enormous flow of assimilates was going out of the above-ground into the below-ground phytomass. With a rapid root growth there was an increased death of roots and the standing crop of below-ground dead mass was high compared with dead mass of another pastures.

**References**

1. Mirkin B.M. Anthropogenic dynamics of vegetation. – M.: VINITI, 1984. (Results of science and technology. Ser. Botany; Vol. 5). – P. 139–235.
2. Nosin B.A. Soils of Tuva. – M.: High School, 1963. – 342 p.
3. Lakin G.F. Biometrics. – M.: Higher. Sch., 1990. – 343 p.
4. Mirkin B.I., Rozenberg G.S. Phytosociology: principles and methods. – M.: Nauka, 1985. – 136 p.
5. Gadzhiev I.M. at al. The steppes of Central Asia. – Novosibirsk: Publishing house of SB RAS, 2002. – 299 p.
6. Sambuu A. D. Succession of vegetation in grassy ecosystems of Tuva // Fundamental research. – 2013. – № 10. – P. 1095–1099.
7. Titlyanova A.A., Romanova I.P., Kosykh N.P., Mironycheva-Tokareva N.P. Pattern and process in above-ground and below-ground components of grasslands ecosystems // J. of Veg. Sc. – 1999. – № 10. – P. 307–320.

## WHAT IS THE ELECTRICAL CURRENT AND THE THERMAL ENERGY AS ONE OF THEM CAN MOVE TO ANOTHER AND BACK

Sopov Yu.V.

*e-mail: sop48@rambler.ru*

---

In this article on the level of individual atoms behavior showed the spatial, i.e. three-dimensional vision of what the heat and alternating electric current. At this level, first, represented the transition of the alternating electric current into thermal energy. And then showed the reverse process mechanism, i.e., how the electric current arises in the thermocouple.

---

**Keywords:** thermal energy, electric current, alternating electrical current, thermocouple

When we turn on an electric stove, through the electric current we get the required quantity of heat energy.

What is the electric current and heat? The academic literature indicates that an electrical current is directed (ordered) movement of the charged particles. In metals, these particles are free electrons. But if someone wants to find how the electric current is converted into heat of the surrounding air from the textbooks, the search will be inconclusive.

The absence of it and many other explanations relate to the fact that the description of thermal energy was based on the molecular-kinetic theory (MKT). The volume of this article cannot give all examples of that are the criticism of MKT. It is quite extensive and it is presented in various works. For example, in [1]. The work was not translated into English. Refusal to MKT allowed to explain not only the nature of the electric current. In reference [2] we can find an explanation how exactly strong interactions may be weak and then become gravity. At the level of the behavior of individual molecules reveal reasons of thermal vertical flows in gases and liquids. There is a fairly simple explanation of what lies behind the term "entropy". More precisely, at the same level of specific atoms and molecules disclose uniform heat distribution mechanism in a closed volume.

The explanations were given only by the help of a discovery.

### **Prerequisites to select a base position and explanations**

In the nineteenth century, many scientists adhered to the caloric theory. According to the theory the heat is a material and elements of caloric repelled from their own kinds and are attracted to other elements of matter. This theory explained a lot, but it was rejected when answers to some questions were not found.

Let us point on main things. One of the questions was that. If caloric is a matter, why when we heat the substance it does not become

heavier? The discovery that changed everything and gave clarity on many physical processes is follow. One and a half centuries ago, no one remembered that under the crust of the Earth there is something which is concentrated in a large amount and it gives heat. It consists of the same elements that repel each other and are attracted to the other.

This finding, fundamentally, alters the vision of all that is related to the caloric, a term which is still used today. With this factor is no longer linked caloric idea, as some weightless liquid. So I depart from the old name, and began to use the term "element of a thermal energy component" (ETEC). And I called my theory (concept) "theory of thermal energy" (TTE). This discovery gave us easy explanation and not only the vertical heat flows in gases and liquids, but also weight change of solids.

So, if ETEC is attracted to all elements of matter, their numbers are easily explained by the transition of a substance from one state to another. The solids present so many ETEC that the force of attraction of atoms to each other exceeds the action of repulsive forces, which gives rise to the same presence of ETEC. With strong heating the substance in its composition is entered such amount of ETEC, plaster components of the atom, significantly alienate the electrons from the nucleus. At the same time weakened the force of attraction of an atom to atom. Further their melting point that bond strength between them weakened to such an extent that they will not withstand the action of gravity. This is what characterized the liquid. Therefore, in the gas state atoms and molecules reside when the repulsive forces between them exceed the force of attraction.

In given links there are great detailed profs that the results of the well-known experiments of Rumford, Humphry Davy, Stern and many others, have other and more clear interpretations. All these experiments were carried out with different environments, but one scenario. Body and even liquid were treated friction, and thus allocated a certain amount of heat.

Since these tests are considered to be proof of MKT correctness. But it's not just experiments should be attributed to the evidence, but rather tied to a clear explanation of the theory. Is there a description of how the drill speed or ice pieces increase the speed of atoms in their structures? Is there, unless, a detailed explanation of how the same action in these bodies increase the amplitude of the vibrations of the atoms? If not, then there is no explanation for the binding to the MKT. That is why a common phrase that the experiences are proof of the MKT correctness should be classified as unfounded declarations. Furthermore, my work [3] provides the evidence that the gas temperature cannot be related to the speed of movement of its molecules in space. In that heat release is important for an explanation that is given below, now let examine all of this with reference to the TTE.

In my work, heat release in gas compression is explained in sufficient detail. Here, I briefly point out that the heat release from the solid and liquid bodies occurs as a result of deformation of atoms and molecules. This is nothing new and it is implied in the caloric theory.

The question is stored in other aspect. Where does the excess heat from? if experience with drilling weighing showed that the mass of a rest body with the chips remained unchanged. Firstly, the weighing was not produced during the heat release process, which is very important. The importance of this point the results of experiments, which are described in [4, 5, 6 and 7]. They show when the body is heated, the fluid and gases reduce their weight. Upon cooling, the process is reversed. And when the temperature is reduced, the former weight is also reduced.

Clarification of the excess heat is explained as follows. The fact that the process of heat release (ETEC) from the shear zone occurs under the action of a tool, such as drill bit.

This means that it occurs at a rate of movement of the working surface of the drill. This is a very important factor. It points out that in all these compression experiments or simple distortion of the structure is produced with a relatively low speed. Now, it should be clarified – in relation to what. The processes of elastic recovery structure, even if incomplete, happen in a natural way. This action may be compared with the next visual effect. Pressing, for example, a small rubber ball by a middle finger and begin to move it so that in the end the ball was pressed against the very tip of the finger. Next comes a point when the ball pops up sharply from the thumb. This occurs under the action of internal forces of its elastic structure. A similar effect occurs with mechanical compression molecules of different substances materials. This means that the elements of heat

that are returned to the weakened zone pressure, do it with their natural speed, i.e. a speed which is close to the speed of light. Such heat transfer refers to the radiation.

Sharp (high-speed) return of ETEC in each atom that is exempt from the pressure, despite the fact that their further spread in all directions at a rate of a conventional heat transfer and convection lead to a local accumulation in the friction zone.

At this point the brief introduction to the essence of thermal energy by TTE finishes and moves to the explanation of what the alternating electric current. The main objective of this article to show the principle of how an electric current is converted into heat. Since modern physics connects the electric current in metals with the motion of free electrons, the explanation will be built on this foundation.

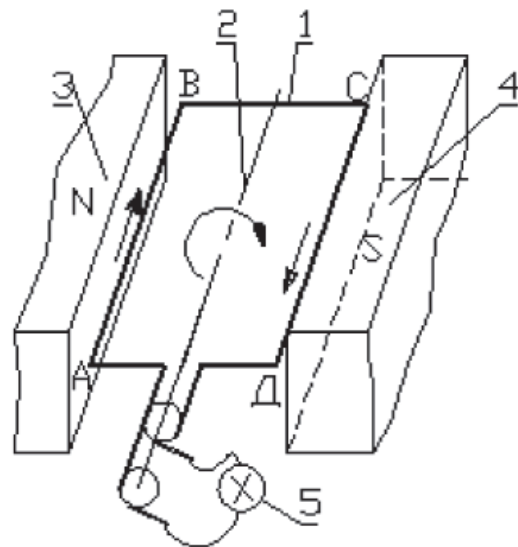

Fig. 1

So, the academic literature informs that in the electron shells of metal atoms are always one, two or three electrons that are very weakly bound to the nucleus. Such electrons are free. It follows that, under certain circumstances, the electrons are loosely attached to the atoms, can leave their seats and move to some distance from its atom. Logically this is possible if the substance has a structure of interconnected voids. By this factor issues should not be, when you consider that the atoms together in complex structures of molecules, should create any voids. Under what conditions, the electromotive force (EMF) occur in the conductor, it is described widely. Therefore, further explanation we can build on the fact that is simply there is. Explanation will build on a simple

alternating electrical current generator, which (Fig. 1–3) consists of the rotary frame 1 around the axis 2 between the two poles of the magnets 3 and 4. Both ends of the frame by means of a system of slip rings and brushes through wires connected to the lamp 5.

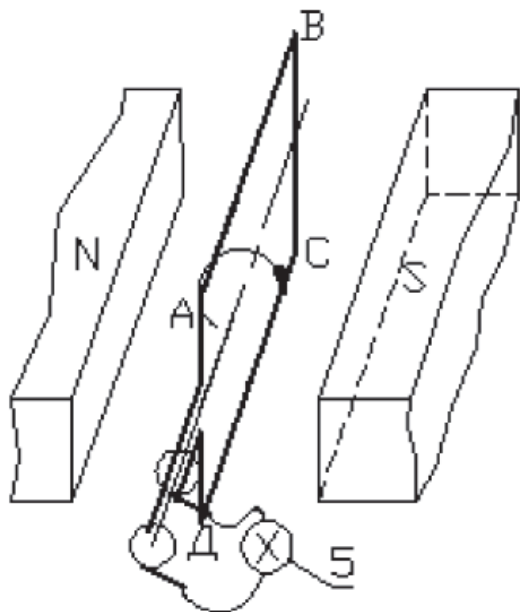

Fig. 2

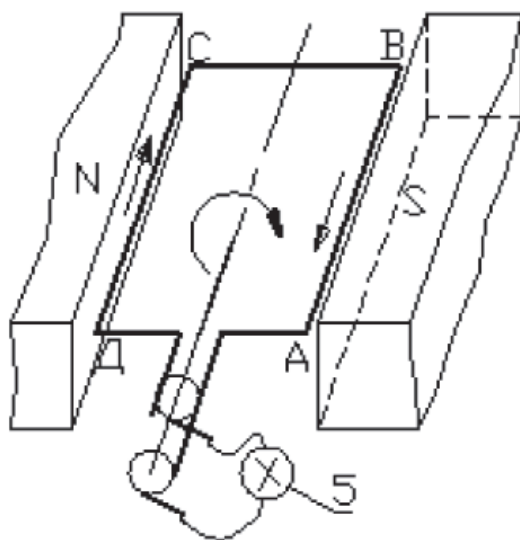

Fig. 3

Occurrence of EMF frames stretch by time in the conductors, i.e. it does not happen simultaneously. First, from the neutral position to a position when the active portions of the frames (i.e. a EMF induced) aligned with the central portion of the magnet pole

(Fig. 1 and 3), there is a build-up of forces on the electrons. The arrows indicate the direction of motion of the electrons. During this time, the electrons under the influence of external forces are forced to move in that direction. For example, from *A* to *B* and from *C* to *D* (Fig. 1). Naturally, part of ETEC that belongs to them, moves together with them. Deeper understanding of how the electrons are confined by TTE in orbital atom may be prepared from materials [1]. During the displacement of the electrons in the same advancement of ETEC direction as the electrons themselves may also occur when other substitution. That is one faced by other, remaining in place of those which have faced. But these are details. Under these circumstances, it is clear that a greater resistance to the movement of electrons obtained when the conductor, for example in the form of a spiral section decrease bulb. Electrons in all circumstances have to move on. Their surroundings of ETEC in cramped conditions can no longer in the same number follow electrons. Some of them are pressed on the surface of the conductor and then go to the surrounding atmosphere.

After passing the central part of the pole, electrons have consistent attenuation in pressing strength on them. Under these conditions, their advance in the same direction become slow. Now we spend the analogy. Exposure to electromagnetic field on the electrons and force them to move forward in spite of their resistance, we thereby subjecting it and all its surrounding to compression. The process of compression is carried out at a rate that is adequate to the speed of the conductor frame portion, which EMF is induced. This compression process is comparable to what we discussed above in the process of mechanical friction. The same comparisons we can make with pressure ease process. Therefore, data comparing indicate that in the period of the weakening of the power of action on the electrons, from the outside they can recover their environment from ETEC at a speed close to the light. After passing the neutral position (Fig. 2) everything is repeated, only this time the electrons are moved in the opposite direction (Fig. 3). After passing the neutral position (Fig. 2) everything is repeated, only this time the electrons are moved in the opposite direction (Fig. 3).

If all this is so, it turns out that electrons are used as a kind of pump. With the use of the electromagnetic force the generator pumping in ETEC conductor, which are not subject to their action. This reductive ETEC flow from the outside to a spiral light bulb do not have to be exactly on its length. If the ETEC sampling in spiral bulb is hindered by its vacuum environment, moving at a speed close to the light, a certain part can be supplied by conductors.

The foregoing occurs during a locked circuit. If the electrical circuit is not locked, the electrons are moved periodically in a dead-end branch or the other. The thicker and longer the dead end of the conductor, in which the seal of electrons take place, than less dense their concentration in it. But since there is still a certain compression and reducing the impact on the electrons, and the heat release occurs appropriate.

#### **Briefly on the thermocouple**

The conductors of different materials have different composition of atoms, different density, it means, communicating cavities of different sections. If there is a temperature gradient flow from ETEC through such conductors, seize and carry away some of the electrons with them differently. That is, in the reverse thermocouples process from the above described.

#### **References**

1. Sopov, U.V. Thermal energy. What is false about it, and where its true? – <http://www.sciteclibrary.ru/rus/catalog/pages/13487.html>.
2. Sopov Y.V. Strong and weak interactions, gravity and entropy have one and the same direction of explanations. – <http://esa-conference.ru/wp-content/uploads/files/pdf/Sopov-YUrij-Vasilevich1.pdf>.
3. Sopov Y.V. Analytical representation of non-compliance of molecular-kinetic theory of reality. – <http://technic.itizdat.ru/docs/Iyriy/FIL14552131500N684498001/1>.
4. Dmitriev A.L., Bulgakova S.A. Negative Temperature Dependence of a Gravity // A Reality. World Academy of Science, Engineering and Technology. – July 2013. – Issue 79. – P. 1560–1565
5. [http://www.researchgate.net/publication/243678619\\_An\\_Experiment\\_with\\_the\\_Balance\\_to\\_Find\\_if\\_Change\\_of\\_Temperature\\_has\\_any\\_Effect\\_upon\\_Weight](http://www.researchgate.net/publication/243678619_An_Experiment_with_the_Balance_to_Find_if_Change_of_Temperature_has_any_Effect_upon_Weight).
6. Dmitriev A.L. Simple Experiment Confirming the Negative Temperature Dependence of Gravity Force. – 2012. – <http://arxiv.org/ftp/arxiv/papers/1201/1201.4461.pdf>.
7. Kishkintsev V.A. About weight concealing from gas masses of its temperature. – <http://www.sciteclibrary.ru/rus/catalog/pages/11717.html>.

## THE IMPORTANCE USE OF TRADITIONAL DECORATIVE APPLIED ART IN OF SCHOOL SYSTEM OF TRAINING TO ART, LABOR AND TECHNOLOGY

Kamak A.O.

*Kazakh State Pedagogical University for Ladies, Almaty, e-mail: Kamak-47@mail.ru*

---

In The article of discusses the pedagogical meaning the use of traditional decoratively applied art of the people in the process of teaching fine art, in art labour working and technology in secondary schools of Kazakhstan and in system of preparation of future teachers. In the contents of the article of reveal the essential problem and the recommended methods of using this kind of art in the educational process as a means in development the knowledge of spiritual and material, art cultural values of the homeland.

---

**Keywords:** school, education, traditional decorative arts, spiritual and cultural values, art, labor training and education

XXI century is modern scientific and information age. As far as moving forward the development of society, also faced new demands to the formation and development of personal life of citizens, professional specialization, are also the same new requirements for the spiritual culture of his inner world. In accordance with the logic of the historical relationship of society, new forms of talents, aspiring to spiritual culture, a new mind, a new fact. The economic, social, as well as the development of other industries, requires a fresh look to the educational activity, analyze the achievements of the critical assessment, organization of innovative educational content and what is happening in the country, economic, social and other prosperity in different areas, the consideration of a new educational activity, differentiation is critical to assess the progress made in maintaining social development of the knowledge and the creative innovation of the population. In order to solve these problems are prepared in the state program "Cultural heritage", "Ethno-cultural education". "Kazakhstan – 2050". In the content of the strategic development program specifically provides that it is the demands of present society: "The younger generation of the XXI century should not only be the object of education, they must also be the subject of spiritual and cultural entity, which should justify their place of creative students." [1]. In this regard, the concept of pedagogical education of Kazakhstan puts a requirement: **"...the future teacher needs to be armed with spiritual and cultural values of education intelligent action"** [2, 3].

But in a new direction of development of the sphere, there are responsibilities require careful look from the standpoint of spiritual and cultural values to the public relations of citizens of different countries, to the truth of life environment. Because the citizens of each period, based on the last generation of historical practice, you need to constantly update,

improve and develop it. Although there are unique requirements, rhythm, peculiar kind of universal turning to the development of a new way, if we abandon the spiritual and cultural values, posted last era then be shaken the foundation of the national culture. Therefore, taking each new thing you must take into account national peculiarities, and to be able to use to search for a special synthesis of traditional and innovative changes in the culture of the past period [3, 204].

Informatization of the educational process in Kazakhstan, a new innovative training, together with the world of educational technology, a combination of the national good made hands of humanity and to the development of spiritual culture heritage, the humanization of all levels of education and educational content is by far one of the most pressing educational problems. Through the educational system of each branch is a significant problem in the formation of patriotic feelings for his native country, spiritual and aesthetic of the young generation. Therefore, one of the responsibilities of each branch of education systems – "... with the demands and requirements of society to modern education, based on national and general human education, and on the basis of achievement of science and practice, the direction of the formation of citizens' Eternal people" spirituality and cultural identity – should be the future of Kazakhstan [3, 204].

One of the means to carry out these teaching duties is art. Art is one of the oldest forms of human consciousness. There are many scientific conclusion, **revealing the psychological structure, means and laws of the perception of beauty art** (L.S. Vygotsky, M.M. Mukanov, B.M. Teplov, P.M. Yakobson, B.P. Yusov, etc.) that influence the formation of the personality of spirituality and aesthetics to reality and art; the versatility of art, the meaning and content, a variety of means and methods of creation, the material world view, and in the formation of

aesthetic relationship to real estate (A. Burov, Y. Borev, I. Matz, B. Baizhigitov, etc.). Psychologist L.S. Vygotskii made the conclusion about the perception's importance of art by saying: "Any theory of art is based on the view that is established in the study of perception, in the study of the feeling, imagination and fantasy" [4, 240]. Also, psychologist B.M. Teplov fastens this conclusion by saying: "The perception of art has to begin with feeling... without it, it is impossible, but the art perception isn't limited by feeling. At first, this perception is "feeling", and then "thinking", besides very deeply and penetrating".

Any art has a unique artistic language, means, peculiar to the art of artistic and aesthetic laws. In any form of art, on the basis of the inherent creativity of the laws, the artist takes the ambient reality and updates in your consciousness beautiful phenomena influenced his sense, and creates his works of art images [6, 5]. The viewer the beauty of these images takes emotional senses, receives an impression, enjoys, and enters into cognitive thought. It follows the notion: mastering the art of not only ongoing practical performance, you should bear in mind that this engendered a close relationship of the psychological process of art education and practical action, means for raising each viewer with the spiritual side. This problem, in the process of schooling and education of adolescents through the arts teaches the creative work that directly relates to occupational specialty in institutes of higher education preparing future teachers.

One branch of this art is a traditional decorative-applied art, a means of education and the legacy of spiritual and material culture, which gives complete information about life, creative talent and the aesthetic Outlook of legibility with communication with real life of people.

#### **Author's purpose**

To uncover the problems use of art and material values in the field of traditional art of Kazakhs, in a humanization the content of school art and esthetic education and as the important requirement of state programs "Cultural heritage", "ethnocultural education" in development [in formation] of spiritual culture of the modern the of young generation

#### **The main chapter**

A pillar of a stable culture – spiritual and material values. It is the values handed down to us from a bygone era from our ancestors: literary folklore, folk music, folklore, customs and traditions, handicraft and folklore heritage of other creative actions. In particular, the legacy of the industry's traditional decorative arts is one of the values, which gives greater oppor-

tunity to learn and to know the students of the folk ethnic, the reality of life and existence and artistic work, aesthetic requirements, the introduction of beauty in the ambient human environment and creative achievements.

The curricula subjects related to the school of fine arts, creative activities:

1. The subject of "Fine Arts" – creative skills of pupils, artistic and aesthetic attitude towards others phenomena of life, the perception of real life and beauty in art, the desire to create beauty with his own hands (motivational) [7, 35–36].

2. "Artistic work" in primary school and in the subject "Technology" in profile classes (grades 7–9) – with the training of labor culture, human relations in employment, with incentives to perform various labor actions, covering responsibilities for the development of creative abilities of search by using samples artisan [8].

In general, the benefits of arts education and upbringing of the young generation of the traditional arts and crafts native teachers, research findings in the development of their educational problems (A. Kamak, K. Eralin, E. Asylhanov, K. Amirgazin, Zh. Balkenov and others), research results have contributed to the introduction of national education and educational duties of school education in the fine arts. These teaching and educational problems are carried out with the help of activities and types of content in terms of "Art works on arts and crafts" school of the subject as a "Fine Arts". Slated accomplished through the development of spiritual and material values in the national art "cognitive" knowledge of life and the reality of the students, while closely associating them with the program principle of aesthetic education "Surrounding reality and aesthetic perception of art." [7, 53–56]. In school subjects as "Labor learning", "Technology" (O. Satkanov, U. Abdygapparova, S. Zholdasbekova, K. Sagynbayeva, A. Shynybekova, N. Rakhmetova, A. Botobayeva and others), the main focus of teachers is to use these arts in research and methodical textbooks, in the content of the textbook on the basis of art and fine arts, skills, performing job actions, pedagogical, methodological problems in this direction [9, 394–395]. But, in our research on labor training and technology, made on the basis of their research results, cognitive traditional decorative art was not considered enough. The value of "national crafts" – learn the steps of the student's work, the fruit of the art to a spiritual relationship of people with reality, the production of objects of art materials with aesthetic value, the main task of artistic and aesthetic education be considered part of an important "benchmark" for assessing the quality [9–10].

Art lovers have long known that the development of the processes of art depends not only on the action.

The process of labor education and training of future teachers of the university system, arts and crafts was introduced as a curriculum school-related actions the nature of art as **pedagogical** (didactic, educational), **psychological** (reception, feeling, cognition, and other psychological processes) possess must be closely linked with **practical** learning processes (introduction to the art) [11]. Each teacher, according to their functional responsibilities should know the importance of providing training and artistic knowledge of the art of creating traditional arts and crafts, material, tin beauty, decoration style, the use of space. Because it is not only the performance of household needs, it is also a means to create spiritual and material values of culture. From this arises the need of humanization of general human values, historical experience and the centuries-old spiritual and material cultural values, art education, education and education. In preparation for future school teachers, it can be understood that the development of national crafts samples, development of didactic, technological, educational demand, methods of work is an important issue, relevant social and moral obligations.

### The Research

Research practice aimed at uncovering the causes of current problems, showed that emotional perception, range of action and activation of motivation directly associated with the creative search of students is due to the lack of unity active motivational action, which leads to action. In the classroom arts and crafts, children, using different materials that they have created a sample of things of different shapes, collect designers decorate. Ways and methods for their manufacture are similar to the work of school subjects as “fine art” and “technology”. But, in labor discipline children only learn to perform the work shown by repeating the teacher (the reproductive method of teaching) by creating a sample things (from the beginning to the end of the work). The objective of arts and crafts of the subject – “with artistic activities of students accustom to making original, beautiful and decorative way of [10] to the content of the compulsory subjects remained outside. The results of our study showed that the development of children’s creativity and the arts should be developed with the help of traditional arts and crafts, which emphasize the need to respect the unity of the following:

1) **pedagogical trend** which is used to implement the principles of arts education and the implementation of the principles of spiritual and aesthetic development;

2) **psychological process**, contributing to the formation of consciousness in children, internal and external motivators (reception-perception, emotional feeling – spatial reasoning – the interpretation and aesthetic preferences – creative effects, etc.);

3) **practical methodological actions** aimed at the development of creative approach to work and graphic activity of the child, (a way to create a work of art, tools, patterns and practices) and aimed at development of creative potential [7, 23–33; 9].

The author based on the results of the study suggested that this wording themes related to this problem: for secondary school teachers: **at first**, are already the subject of “Fine Arts” they need to know the contents of objects of decorative and applied arts, with regard to their work – the organization of artistic education is very important to know the related materials, style design, the beauty of forms, their purpose in life, etc. as ethnic, aesthetic and spiritual values, and anything else that relates to the art. Because art is a means to create spiritual and material culture, and repayment of the population’s needs. **Secondly**, different subjects that help expand knowledge, technology of processing of natural materials, processing technology, creating beauty and artistic decoration, design, elegant cognitive knowledge about the traditions of decoration; **thirdly**, the combination of art design with work; **fourthly**, in the classroom work of students should use a variety of materials, processing, modeling, product, technology through the development of skills to create your own beauty inherent in the area of content search, the awakening of interest in the creative development of each subject should be major requirements [9, 395].

### Deduction

Due to problems based on our ongoing research, training future teachers in the school of fine arts, art, and technology functions to preserve the unity of the educational integrity, to be achieved by means of the possibility to implement a comprehensive and high-quality result. These charges are the following:

– **the cognitive:** To help learner understand the nature and meaning of art and the value of human life, to know the arts and crafts style, educational concept, through his spiritual, cultural and historical value, and inform people about the real values of the world in art;

– **the upbringing:** to generate interest in traditional craft by using their own artistic and aesthetic values, attitudes, tastes, cultures and national traditions of students in secondary education, reviving interest in the history of their native land and the people;



– **the developing:** art products and the ability to discern the signs of aesthetic value, the idea of role in the functioning of the system, creates a huge opportunity for the development of the efficiency of interpretation; learning objectives are distinguished by choice of materials and products that improve the ability of search, thus developing a productive work search;

– **the socialization:** to awaken in the child a sense of pride for the art of its people, contributes to the formation of his social relations to changes in world culture, o people and motherland, effect on the awareness of its civic involvement to these changes;

– **the communicative:** cultural heritage, arts, national understanding of the nature and style of his peers and teachers, and develop the ability to exchange views; mutual help in labor, “business” would be ensure the development of communication skills [9, 396-397].

These mentioned functions of Higher Education Institutions in its pedagogical practice process are a guarantee of the quality of training of future teachers.

### Conclusion

On the basis of certain problems and ways in the text content, we offer the following requirements aimed to solve them:

– social, aesthetic traditions of the population, art ideas for change, for the creation of art forms, the formation of the ability to analyze the reasons for the growing interest in change;

– by means of arts, the opportunity to participate in public life and control the human values, to explore the ideological mechanisms of formation for activation of the beneficial use of artistic and aesthetic education schools, and training should be the main direction of humanization;

– the young generation in the field of art that affects the mental processes, and contribute to improving the quality of education in the field of art and aesthetic connection with the requirements of education and training, the learning process should be implemented as a special task.

– to revive the interest of pupils to the national art, including traditional arts and crafts, educational and aesthetic connection with the works of masters of material and cultural values of the country to ensure the knowledge of a precious heritage;

– the formation of spirituality and culture of the student for creating a new educational platform and refined educational principles, the combination of advanced samples and educational principles, effective combination of technology with the best pedagogical samples; Humanitarian and educational work in the context of beneficial use; Lessons, outside school art activities on the consideration of education.

### References

1. Nazarbayev N.A. – “Kazakhstan – 2050” khalykka zholdauy (Message to the people “Kazakhstan – 2050”) // Egemen Kazakhstan. (in the kazakh language).
2. Conception of Education Development in the Republic of Kazakhstan up to 2015. – Astana, 2004. (in the kazakh language).
3. Kamak A., Tattibayeva G. Kazakh khalkynyn dasturlary oneryndegy rukhani madeniet kundylyktaryn igertudyn manyzy (Pedagogical importance studying of spiritual cultural values of in traditional art of the Kazakh people) // Zdenys. The scientific journal of the Ministry of Education and Science of the Republic of Kazakhstan. – 2013. – № 2. – P. 204–207. (in the kazakh language).
4. Vygotzsky L. *Psychologiya iskusstva* (Art psychology). – M., 1987. – 240 p. (in Russian).
5. Teplov B. *Sposobnosti i odarennosti. Izbrannye trudy. Tom 1* (Abilities and endowments. Chosen works. Vol. 1). – M., 1987. (in Russian).
6. Baizhigitov B. *History and theory of art. Textbook.* – Almaty: UIB, 1999. – P. 198.
7. Kamak A. *Sistema obucheniya izobrazitelnomu iskusstvu v shkole. Uchebnik.* (System of training of a subject of the fine arts at school. Textbook). – Almaty: Orchon, 2014. – 288 p. (in Kazakhstan).
8. “Prikhodnoe iskusstvo” dlya 1–4 klassov. – Astana, 2013; “Tehnologia”. Programma obucheniya. 5-9 klassov. – Astana, 2010. («Arts and crafts» for grades 1 to 4. – Astana, 2013; “Technologia”. Education program. Grades from 5 to 9. – Astana, 2010).
9. Kamak A. *Osnovnaya problema ispolzovaniya traditsionnykh remesel v sodержaniy trudovogo obucheniya* (The main problem of use of traditional crafts in the content of labor training) // Proceedings of the international scientific conference. – Astana: Eurasian National University named after L. Gumilov, 2015. – P. 293–297. (in the kazakh language).
10. Kamak A., Etiyeva A. *Khalkymyzydyn enbek dasturlery kundylyktaryn mekteptyk “Enbekke baulu” zhne “Technologia” panderyn okytuda paidalanudyn tarbielyk mahyzy* (Educational value of using traditional labor values of our people in the process of learning of school subjects as “labor training” and “technology”) // Bulletin of the Kazakh National Pedagogical University. – Almaty, 2015. – № 3 (47). – P. 148–151. (in the kazakh language).
11. Kamak A. *Psychological factors of learning the fine arts at school* // International Journal of Applied and Fundamental Research. – Germany, 2014. – A der Trift 30, № 2.
12. Kamak A. *Mekteptyk korkemdyk bylym mazmunyn rukhani-madeniet kundylyktar negyzynde gumanizatsyalau problemalary* (Issues of humanization on the basis of spiritual and cultural values of school education on art) // Proceedings of the second international scientific conference. Ministry of Education and Science of the Republic of Kazakhstan and the Department of Education of Astana city. – Astana, 2013. – P. 273–280. ( in the kazakh language).
13. Kamak A. *Development of national spiritual and cultural values in the course of training to art* // Bulletin-Conkorde. – Vol. 2. – Paris, 2014. – P. 49–54.
14. Borev Yu. *Esthetia.* – M., 1988. – 496 p. (in Russian).
15. Meilach B. *Chudozhestvennoe vospriatie kak nauchnaya problema. V knige: Chudozhestvennoe vospriatie* (Art perception as scientific problem. In book: Art perception ). – L., 1971. – C. 388. (in Russian).
16. Yusov B.P. *Vospriatie iskusstva I vozrastnye osobennosti shkolnikov. V kn.: Rol chudozhestvennykh museev v esteticheskom vospitaniy shkolnikov. Ch. 1.* (Perception of art and age features of school students. In book: A role of the art museums in esthetic education of school students. – M., 1973. (in Russian).

## FORMATION OF ECOLOGICAL CULTURE OF THE STUDENTS AT THE NATIONAL SCHOOL

Khusainov Z.A.

*Kazan (Volga) Federal University, Kazan, e-mail: zaudet@inbox.ru*

---

Of the pedagogical system based on knowledge of the Tatar people on the nature, implemented on the lessons of natural Sciences and geography of Tatarstan is an interconnected set of means, methods and processes that contribute to the formation of ecological culture of the students. The funds of the national pedagogies, traditions, rites and customs of the people of their environmental content establish stable norms and rules of behavior of children in nature, contribute to the education of ecological culture.

---

**Keywords:** culture, education, ecology, national school of folk pedagogy

Tatar people, summing up its monitoring of natural phenomena, accumulated environmental skills and apply them in practical activity: reasonably ploughed the earth, fertilize the soil harmless substances, in time spent sowing, organized косовица, cleaned bread etc All this is reflected in the experience, traditions and ceremonies of the people and in oral folk art: in Proverbs, sayings, riddles, legends, songs, bait, munadjat etc. So they have become treasure ecological knowledge, skills and transmitted from generation to generation through the mechanism of succession of traditions, ceremonies, holidays. Since ancient times people have been based agricultural technology of his works was aimed at the reasonable handling of the earth, which in part still not restored. People were in full dependence on natural conditions, and so his mind was supposed unity of man with nature, without which he knew, it was impossible the very existence of man.

Meanwhile, the historical-ethnographic material suggests that the ancestors of Tatars were aware of their connection with nature. The process of knowledge of their environment was consistently, constantly developed and deepened. Unique data Tatar folklore reveal the organic link between man and nature. Legends of the past serve the noble goals of our era – more deep understanding of nature, education of ecological culture of new generations.

The aim of the study is to develop the content and methods of forming of ecological culture of the students of the national school-based knowledge of the Tatar people on the nature.

### **Type and method of selection of the study**

When organizing the survey took into account the theoretical positions and the conclusions drawn by outstanding teachers K.D. Ushinsky, A.S. Makarenko, V.A. Sukhomlinsky about the role of nature in the upbringing of the younger generation.

In the work took into account the results of the research N.W. Bljgoz, E.A. Grineva, A.D. Garayev, G.A. Ivanova, V.M. Minayeva,

L.D. Bobyleva etc. about the content, method and terms of formation of ecological culture of the students in obtaining the natural-geographical education.

The ecological problem ceases to be a problem of individual Nations and is becoming global. On this basis, in researches we base on the works of domestic and foreign scientists: S.D. Derjbo, V.A. Levin, G. Hefling, F. Saint-Marc and other Studies of scientists of foreign countries, dedicated to the problem of environmental protection from various types of pollution, including in our Republic arrows in the fast growing.

### **Materials and methods of research**

The basis, the Foundation of the formation of ecological culture of a person is knowledge. The child receives them in school, learns from the media, extracts from books and uses knowledge of their people about nature. This, above all, knowledge of the basic laws and interrelations in nature and society, the violation of which generates negative and irreversible processes that are destructive of nature, society and man.

Another fundamental part of ecological culture, forming of moral and aesthetic attitude to reality, are emotional-sensory experiences. This, above all, emotional and value, deeply moral attitude towards nature, society, the people. All moral orientation of the child should be oriented on the development of such feelings as love, conscience, an experience of communication with nature and people as the highest human happiness. Nature has a great educational power. In unity with directional sense exists and manifests aesthetic sense. The child needs to develop a feeling of natural beauty, harmony, the ability enthusiastic attitude, experience a beautiful, exquisite, and sublime [1].

Ecological culture of a personality is being formed in the integration of the three areas: environmental consciousness, moral-aesthetic, active, practical relations. Violation of one of these areas of environmental upbringing and education in the underestimation of the other can lead to the formation of the aggrieved person or the rationalist-contemplator, or barren theological admirer, or pragmatics satisfied only utilitarian benefit, without considering the consequences of their activities.

The formation of ecological culture of the person, first of all, not so much the weapons of its environmental skills and knowledge but the creation of ecologically and

morally pure inner world. Spiritual purity is the main condition of development of ecological Outlook of the personality, its ecologically gentle outward behavior and activity. In modern unsettled world young person is in danger of dehumanization personality. Ecological culture, intelligence, spirituality and unbridled passion for profit, absence of control and animate egoism two incompatible directions. Young people embarked on the path of speculation, pimping, drug abuse, the pursuit of easy success, sharpening, gambling, blackmail and violence will never be able to know what the intelligence and ecological culture as spirituality and activities. Today's economic, political, social and cultural situation opposite to the trends of development of ecological education of youth.

However, it is necessary to confront this direction. One of the ways of confrontation is a religion.

The study of our problems are interconnected with the knowledge of the Tatar people on the nature as the basis of forming of ecological culture of a person, in this regard, we adhere to the Islamic religion. Studying of educational ideas laid down in the Qur'an, we come to the conclusion that the basis and essence of Islam is the education of high-minded, thoughtful, fair and righteous people. These qualities serve as a measure of mental development of a true Muslim. People with positive qualities are the best people to Allah. Because, a Muslim, not deliberately seeking to develop these qualities, rather like a soulless, empty, unthinking gramophone: only mercy and compassion, humanity and decency, good breeding, decorum, knowledge and diligence, fairness and love to all people and creatures of Allah transform the person into true Muslim. To preach the Quran without producing consciously in yourself those qualities is a disgrace and a mockery of religion of Allah.

In accordance with the Qur'an, man is responsible to the parents, neighbors, and before the close. This liability is further covers even all humanity, wildlife and plants. Not allowed, for example, hunting of birds and animals for entertainment. Fruit and other trees can be cut only after special permission, in exceptional cases. The Islamic religion commands to the alive and nonliving nature of selfless charity, generosity, kindness, justice, honesty, recommends that the kindness and generosity. The Koran says: "If you do good, you do for yourself, and if you do evil, then for ourselves..." [2, p. 17/7].

The major moral virtues of Islam create the necessary preconditions for achieving social well-being in most of the higher degree.

Islam purifies the soul of man from selfishness, cruelty and terror, from vanity and promiscuity. He is a supporter of the God-fearing, dedicated, disciplined, fair. It stimulates the sense of responsibility and self-control. Confirming these words in the Qur'an is written: "Not equal good and evil. Deviation same what is better: then will he between whom and thee was hatred become as though he were a close friend. But never given it to anyone, except those" [ibid., p. 393].

A certain part of the Qur'an is its legal, ethical and aesthetic aspects. This environmentally educates people on the inside.

In the early X century (921–922) our Bulgarian grandparents adopted the Islamic faith. Traditions and customs of the people are brought into line with the Quran installations. Pre-Islamic experience harmony with nature was extended to the connection with the cosmos. Our people have developed a purposeful system of ecological

education, forming of ecological culture, which we today try to revive. A special place in this system is given to the formation of the careful attitude of the young generation to nature [3].

The pre-Islamic period of our nation is characterized by the fact that he idolized the objects of nature. Every tree, stream, river, hill, a lake, boulder, etc. had its spirit. Before cut down the tree, to dam the river, align the hill, etc. that people needed to win the "owner" of this natural site. If people did not care about these hosts, you could lose their grace.

The Tatar people has exceptionally respectful attitude to the native places of their habitat, especially sacred springs. In memory of modern Tatars they are saturated with information of the Holy and entrenched views about the existence of the various intangible forces. The person's attitude to these intangible forces carries with it special rules of behaviour in nature, based on the veneration of the spirits, caution in action, respect for the environment. This way of life was of exceptional importance to the conservation of pristine environment only because ensured peace among all species of fauna and flora in the breeding period, contributed to sustainable functioning of natural ecosystems. In turn, nature gave our ancestors beauty and high level of productivity.

The ancient view of the world Tatars was imprinted on their public behavior and formed rational nature management. These included limiting the effect of using the resources of nature, that is to extract as much as you want to stay and not more. Simultaneously, it was decided instead taken the same and restore.

Therefore, the religion of ancient Tatar prevailed priority of nature over many generations Tatars, despite densely regions of their habitat, helped save the primeval nature and its high level of productivity. Thus, our ancestors, deifying Mother Nature, treated carefully to natural objects that have harmonized their relations with it, seeing it as a living being. It was the first unwritten laws on environmental protection, the original environmental culture [4].

The process of forming responsible and value relationship of the individual to the environment is carried out throughout his life and is largely dependent on the knowledge gained from the lessons of natural Sciences and geography of Tatarstan. These lessons laid the Foundation for environmental education and upbringing of students is determined by the level of ecological culture.

On the lessons of natural Sciences teachers rarely used problematic presentation of the material, do not use partial search research and teaching methods. It is for this reason there is such a paradoxical situation: in the process of transfer of students from primary school cursory knowledge of nature and the environment in secondary and senior classes, their interest in the teaching of geography and natural cycle does not increase, but, on the contrary, decreases, which leads to deterioration in academic performance.

Today's children grow up in a world of diverse information. They look interesting TV programs about the life of nature. For example, about the expedition to the seabed (a Custo), about the life of a Dolphin and its communication with people ("flipper") or about what you can teach your dog ("Dog-show"), etc. today. However, many teachers of natural Sciences traditionally looked at the lessons of sparrows and the Raven, lime trees, near the school.

### Results of research and their discussion

One means of raising the scientific level of knowledge of the Tatar people about the nature and development of the cognitive abilities of students is the use in educational process on the natural history and geography of Tatarstan inter-subject links. The natural history and geography of Tatarstan the content is closely connected with other educational subjects. Many of the concepts of nature studies and geography of Tatarstan may not be understood and internalized by students without the basic knowledge of botany and Zoology [5]. So, study materials on local and regional soil cover, flora and fauna of our Republic by natural zones and their relationship becomes understood only through the knowledge of biology.

Consider the lesson of geography of Tatarstan in the 8th grade teacher of secondary school № 27 in Kazan N.M. Nyrzianova. According to our technique experienced in class, she gave students a figurative representation of the forests of the Republic with the same textbooks, maps of the Republic of Tatarstan, video "Forest" and during the same time, as in test class, but with the inclusion of intersubject communications, knowledge of the Tatar people on the nature. After making the students are brief characteristics of the forest zone of the Republic of them were offered the following questions:

1. After watching the movie "Forest" to answer the question:

"The forest of Tatarstan differ from Russian taiga?"

2. To give examples of the flora and fauna of botany and Zoology. At the end of the lesson the students under the guidance of a teacher summarized the studied material.

In the next lesson was conducted a written survey of students on the question: "How I present myself forests of Tatarstan". The results of written work in the experimental class showed more complete and specific learning than in the control (Table 1).

In the written work of pupils of the experimental class when compared flora and fauna of Tatarstan and Russia showed their peculiarities and differences, and in the control class, there was no comparison.

We give examples of the responses of the control and experimental classes with the same performance, the General development and psychological warehouse.

M. Siraeva, control class: "In the forests of Tatarstan the plant and animal world is various. Grow pine, birch, and aspen. Fauna is also varied. Live squirrel, Fox, hedgehog, and birds woodpecker".

Barieva L., experimental class: "Forests of Tatarstan" stands before me a beautiful forest with different kinds of plants – from short grasses and shrubs to high pines, in 2–3 times the pillars of power transmission lines. Their length of circumference exceeds 2–3 our grasp. Below pine trees are deciduous trees: lime, birch, maple and others.

If to compare our forests and taiga Russia, it is common between them is very small. Taiga consists of coniferous trees, and our forests are a mixed multi-tiered forest. In the taiga fauna richer than in our forests.

Forest riches of Tatarstan. Ancient Tatar people said: "Treelessness – inconvenience". He is right in his statement" [6].

As we can see, the answer Schoolgirls experimental class is different from the answer Schoolgirls controls the completeness, consistency, availability comparisons, concreteness. The results of the experiment in two classes confirmed our assumptions about the effectiveness of the application of interdisciplinary connections and knowledge of the Tatar people on the nature in the educational process.

### The conclusions

1. The main objective of developing pedagogical technologies on the natural history and geography of Tatarstan is the orientation of the educational process on the formation of students' ecological culture.

2. Pedagogical system based on knowledge of the Tatar people on the nature, implemented on the lessons of natural Sciences and geography of Tatarstan is an interconnected set of means, methods and processes, which contribute to the formation of students' ecological culture.

3. Experimental study shows that in modern conditions clearly defined two different opinion: traditional and non-traditional types of lessons on natural history and geography of Tatarstan.

**Table 1**  
The results of the answers of the students on the description and intersubject public relations

Classes	Number of pupils in them	The complete description	Incomplete description	Reflection of intersubject descriptions	The specific answers
Experimental class	26	23	3	24	19
The control class	24	10	14	2	4

Table 2

The characteristic of the basic features of traditional and non-traditional types of lessons on natural history and geography of Tatarstan

Components of the pedagogical process	The overwhelming content	
	Traditional lesson	Unconventional lesson
Purpose	To equip students with the knowledge, skills	The development of students' thinking abilities, mastering the methods of training activities
Actualization	Texts, examples, facts	Rules, concepts, theories, laws
Forms of education	Frontal	Collective way, group
Teaching methods	Verbal, visual, and practical	Problem summary of the material, partial search, research

4. Systematic non-traditional types of lessons on natural history and geography of Tatarstan, containing innovative ideas, promotes the learning of new material in much greater quantities than this program.

5. Pedagogical innovations, realized on the lessons of natural Sciences and geography of Tatarstan, contribute to the formation of students' ecological culture. Knowledge of the essential features of different types of lessons on natural history and geography of Tatarstan helps teachers to understand the novelty, practical value of specific technologies that contribute to the formation of students' ecological culture.

#### References

1. Volkov G.N. Pedagogy / Ed. prof. I.T. Ogorodnikova. – Cheboksary Chuvknigoizdat, 1974. – P. 376.
2. Quran: Per. from Arabic. I.Yu. Krachkovskogo. – 1990, SPIKA. – P. 512.
3. Khusainov Z.A. Regional model of ecological culture of pupils: monograph. – Kazan, Eeocenter, 2002. – P. 160.
4. Khusainov Z.A. Ecological Culture schoolchildren: monograph. – Deutschland, Saarbrucken, Palmarium academic publishing, 2012. – P. 401.
5. Khusainov Z.A., Nandigram. Textbook for high schools. – Deutschland, Saarbrucken, Palmarium academic publishing, 2012. – P. 304.
6. Khusainov Z.A. Technique of training of geography and ecology of the Republic of Tatarstan. Textbook. benefits. For top. Textbook. institutions. – Deutschland, Saarbrucken, Palmarium academic publishing, 2013. – P. 236.
7. Saint-Marc F. Socialization nature / Per. from French. L.M. Stepacheva. – M.: Progress Publishers, 1977. – P. 437.
8. Toffler E. The Third Wave. Moscow, Infra. – M., 1999. – P. 16.
9. Toynbee A.D. Civilization before the court of history. – St. Petersburg- M., 1999. – P. 27.
10. Hoeffling G. Anxiety: Time Bomb on our planet. Per. with it. M.S. Osipova, Y.M. Frolov. Pre. S.B. Lavrov. – M.: Thought, 2000. – P. 270.

## COGNITIVE PROCESSES OF THE POLITICAL PSYCHE

Bozadzhiev V.L.

*Chelyabinsk State University, Chelyabinsk, e-mail: bvl\_psy@inbox.ru*

---

This article is an attempt to briefly describe the cognitive processes, which are viewed as one of the political psyche components, along with emotional-volitional and behavioral components. The idea of the political perception is given in the article. A brief description of the political memory and its importance in the preservation of the historical memory of the people is exposed. Particular attention is paid to the political thinking and such of its characteristics as independence of thinking, its criticality, depth, flexibility, width, speed and creativity. In the characteristics of the political imagination the importance of its most common forms – political myths and political utopia – are emphasized.

---

**Keywords:** cognitive process, political myths, political utopia, political psyche components

Political psyche is a reflection of a particular form of the active subject of social and political processes and phenomena occurring in the social and political interaction of the subject with the outside world and it performs in his behavior (activity) regulatory function. The political psyche opens to the subject not the political situation (political processes and phenomena) as it is, but the field of its action, i.e., those objects of the politics and those of their features which are important for the life of the subject. The psyche in the political and psychological analysis consists of three main blocks: cognitive, emotional-volitional and behavioral. We will focus on the brief analysis of the cognitive block, which includes the political perception, political memory, political thinking and political imagination.

**The political perception** is the perception of politics as such, the perception of political leaders, political groups, political power, political information, and other objects which are directly related to the politics. Back in the 1920–1930s, in the numerous experimental studies of the American psychological school «New look» it has been proved that our perception depends on the attitudes and stereotypes of our consciousness, and in the political terms – of the political consciousness, political self-consciousness and political culture. Moreover, it is evident impact on the unconscious level. If we impose contour images of the car and the horse one on another, and then show this seemingly meaningless set of the lines to the Americans and Mexicans, most Americans surely see in this “picture” a car, and most Mexicans – mustang. The same can be done by putting images of a violin and Kalashnikov one on another. Most Palestinians, Afghans, representatives of any other long-combatant community will see only a Kalashnikov (today it is depicted on the national flag and national emblem of Mozambique), on the contrary the majority of Europeans see a violin [5].

Political perceptions, as well as the perception itself, is comprehend and selective. This

selectivity is being formed in the process of the political socialization – “growing” the younger generations in the adult, political world. These features, being formed, are related to the perception of political culture, political consciousness, political self-consciousness, as well as other functions of the human psyche.

**Political memory** is characterized by the processes of remembering, preserving and reproducing political events, social and political processes and phenomena by the individual, group, and society. The value of the political memory as a psychological phenomenon, is, firstly, that a good memory is a necessary feature of the political leader’s personality who has to pass through his mind vast amount of information that has a direct or indirect relation to the different political events of the society. And we are talking not just about imprinting, memorizing, but about ability to select and store certain blocks of information directly related to the nature of the activities. Secondly, the memory of the certain groups of people and historical memory of the people in common are interesting for political psychology. If, for example, in the Soviet period of our history, especially in its first decades, some people had to hide their aristocratic origins, in the post-Soviet period there were descendants of the noble families, who claimed their “noble” origin [6].

Historical memory indicates that some events with time fade in the memory of the people (the death of Stalin, the fall of the Berlin Wall, the economical default in Russia of 1998), while others are stored in the memory without losing their political relevance (Victory in the Great Patriotic War, the Chernobyl catastrophe, the collapse of the Soviet Union), and the value of some even increases eventually (the flight of Yuri Gagarin). And it is important that it happens not because of absolute time range, but because of the political relevance of an event at any given point in time for the historical memory of the people.

**The political thinking** is a key and determining component of the political structure of

the psyche. It is socially conditioned and inextricably linked with the speech process of indirect and generalized reflection of political reality in the course of its political and psychological analysis and synthesis. The political thinking includes not only cognitive, but also emotional-evaluative mechanisms with its own ontological status. Basically it is an important feature of the political thinking is its extreme lack of logic. G. Lebon wrote about the crucial role of the irrational mechanisms, emotional evaluations in the actions of the masses at the turn of XIX–XX centuries. The cause of the social dynamics at that time he saw in the constant change of ideas: being originally the intellectual and spiritual heritage of one man, a certain idea “via infecting” penetrates in “the soul of the masses”, finding more and more adherents. The idea itself in this case is being inevitably simplified, almost losing its original intellectual originality, becoming a dogma, ie, absolute truth on the emotional basis. Strictly speaking, only in this converted, almost irrational form the idea can provide social regulating effect on masses [3].

It is clear, however, that the ability to think politically have not only politicians, but also any person, any subject of public relations, even not deliberately engaged in the political activity. The implementation of this capability in one or another person depends on the existence of his interest in the political processes and phenomena; on the level of political participation in the life of society; on the level of his political culture; on how a person perceives the political reality, and how he refers and evaluates it, etc. From this point of view, it follows that the political thinking is peculiar to any person – any member of society.

The political thinking is characterized by almost the same intellectual actions and operations, like any other thinking: such as analysis, synthesis, comparison, generalization, abstraction, classification and systematization. The same applies to the forms of thinking, because the results of the thinking process (thoughts), as it is known, exist in the form of judgments, reasonings, conclusions and concepts. Particularly the individual characteristics of the political thinking should be noted: independence of thinking, its criticality, depth, flexibility, latitude, speed, creativity.

*Independence of the political thinking* is inherent in the people who able to set their own goal and achieve certain purposes and solve tasks without any help from other people. Such individuals are quite actively and effectively take into account and use in addition to their own experience, experience of other people, they process this experiences creatively; they critically approach to the analysis of the theory and practice of public life.

*Censoriousness of the political thinking.* Individuals with such feature of thinking are not just critically evaluating everything they know, see, are able to do themselves and other people, they can not be blindly influenced by other opinions, other people’s motives. As a rule, these people (politicians) are well mastered in the art of identifying differences between “for” and “against”, in making decisions. Both these features of thinking, as a rule, are formed with the acquisition of not only knowledge, but also the relevant experience by a person.

*Depth of the political thinking.* This feature of the political thinking is characteristic for politicians, who are able to penetrate deeply into the essential features of the certain maxims, phenomena, events; to separate the important from the secondary, to identify causal relationships and characteristics of the social phenomena, etc.

*Flexibility of th political thinking.* This feature of the thinking is rare. It is characteristic for those people who know how to change quickly their thoughts, getting rid of what is already stuck in them, in their minds as a result of life experience, or what is deficient, outdated, inaccurate. Such politicians can quickly master the various, especially progressive, political technologies and perfectly possess them. The ability to choose unconventional, innovative techniques and solutions of the specific political problems helps these politicians to adapt themselves quite well to the specific political situation, to act rationally and efficiently.

*Width of the political thinking.* If a person (politician) is able to cover a wide range of issues, link them, separate the main and secondary things, and then take the alternative optimal solutions, it means that he thinks out of the box (widely). This feature is most common for people highly knowledgeable, open-minded.

*The speed of the political thinking.* This feature is inherent in individuals (politicians) who are able to quickly understand complex situations, taking the most thoughtful, accurate and optimal solutions. To some extent, speed of thinking depends on the psychological state of the individual, on mobility of the nervous processes, however, as a rule, people get such quality as a result of thorough training, training of mental activity.

*Creativity of the political thinking.* This feature is especially important for person involved in spiritual, artistic, political activity. It is connected, first of all, with the ability to think out of the box, widely, originally, to have knowledge and experience of the other people’s work, to make unconventional decisions.

These individual peculiarities of the political thinking are being developed and improved only in the process of constant mental

and practical activity of a person. Any political action is the result of sensory perception, appropriate interpretation of the specific situations, events and actions for the different political subjects.

**Political imagination** is considered, as a rule, in the context of the political views which are quite rare in its “pure” kind. Most people use different ways to develop their political views, and these views may differ drastically depending on the object or area of the reality. In spite of the ignorance of many ordinary citizens in particular matters of the internal and foreign politics, it does not mean that these people do not have rational ideas or ideological stereotypes affecting their socio-political problems of life [1].

Collective creative imagination is the form of the political views. Political imagination can be considered as the process of creating a complete image of the new political reality on the basis of processing and creative transformation of the political ideas. You can select different ways to transform these ideas into images of the imagination: the analogy, emphasis, exaggeration.

Political imagination is sometimes seen as a sudden “revelation”, leading to the creation of the new political image, the opening of which is being prepared in the process of finding solutions.

Political imagination can be *involuntary* (futile fantasy, which leads person far from reality) and *arbitrary* (conscious formation of the political images, in accordance with the purposes and tasks of the activities). The latter is divided into *recreating* (the construction of the political images on the basis of mediated symbolic information) and *creative* (creation of the new political images).

The most common forms of the political imagination are political myths and political utopia.

Political myth is illusory imagination which is perceived uncritically. It replaces and displaces understanding of the political reality. Political myth as a form of illusory comprehension of the political world includes either insight or misleading. Political myth may implement intimate human desires and aspirations, his hallucinatory political experience and features of both individual and collective unconscious. Political myth arises when people are faced with a daunting task, solving of which exceeds their natural features. The symbolism of the political myth defines it’s most important features – weak articulation, lack of internal compartmentalization of thinking. It is a feature of the mythological imagination – an implicit division, and occasionally fusion

of the political subject and political object; object and sign; word and deed; creature and it’s name. As a rule mythological thinking operates situational-specific and individual external features of the political object.

In the analysis of the political utopia it is necessary to distinguish two cognitive traditions, one of which is based on axiological, and the other – on the substantive aspects. From the position of the first approach political utopia is seen as the certain desire, which can not be done under any circumstances, and therefore acts as unattainable political ideal. In line with the second approach, political utopia is interpreted through the concept of transcendental knowledge: critical in relation to the present and “advancing” the future [4].

Psychological basis of utopias, as well as the myths, performs the tendency of people to illusions – a distorted perception of the political reality. One of the sources of the political illusions is subjectivism, leading to deformation of the time perspective, when the realization of the political ideal is transferred to the other periods. Illusions of different kind are not excluded: typical illusions of turning historical points. There may be political illusions related to “running too far ahead”, creating political ideas which achievement is unrealistic. Utopianism is manifested in the substitution of the real with unreal. Substitution of the epochs often leads to illusory notions, to a shift of the object’s form of the time being. Bearers of the political illusions are not so much individuals but certain groups of people. Some of them seek to eliminate the formed political norms of life, while others – to keep them in any way [2].

Cognitive block, of course, does not give a complete picture of such complex phenomenon as the political psyche. It is included in the complex processes of the cooperation, complementarity with emotional-volitional, value-orientation, need-motivational sphere of the political psyche.

### References

1. Diligensky G. Social and political psychology. – M., 1996.
2. Korshunova L., Pruzhinin B. Imagination and rationality. Experience of the methodological analysis of the cognitive functions of imagination. – M., 1989.
3. Lebon G. Psychology of the people and the masses. – M., 2010.
4. Lubsy R. The political mentality: the methodological problems of the study. – Rostov-on-Don, 2001.
5. Olshansky D. Foundations of the political psychology. – Yekaterinburg, 2001.
6. Shcherbinina N. Politics and Myth // Bulletin of the Moscow State University. – Ser. 12. Political Science. – 1998. – Issue № 2.



## MANAGERIAL NOVATIONS IN CONSTRUCTION USING INFORMATION-COMMUNICATION TECHNOLOGIES

Kunyaev N.E., Martinov L.M.

*Bauman Moscow State Technical University, Moscow, e-mail: nikolaykunyaev@mail.ru*

The article analyzes new demands placed on modern business associations of the construction sphere. In conditions of knowledge based economy it is necessary to take into account tendencies of the increasing use of information-communication technologies. The authors of the research found out that the key point in the implementation of effective relationships between business associations members of the construction sphere is the InfoCom-system. Requirements to increase the level of interaction of managing business organizations to implement effective management decision by the management of business associations in the construction sphere under it's material-virtual business environment were identified. These management innovations allow to provide such cooperation with the implementation of a functional relationship to ensure all business enterprise structures within the boundaries of the business associations of the construction sphere on the basis of the use of info-communications and information-communication technologies.

**Keywords:** material-virtual business environment, InfoCom technologies, InfoCom-system of management, source "knowledge", construction sphere

Currently, the increasing use of information-communication technologies (ICT) in contemporary business associations of construction sphere is of particular relevance. In this regard, the article deals with three issues related to the managerial innovations in terms of material-virtual business environment (MVBE):

1. Tendencies in construction sphere due to the use of ICTs.
2. Features of management association activities of the construction sphere in terms of MVBE.
3. Management innovations with the use of ICTs for management in business associations of the construction sphere (BACS) under MVBE.

An analysis of set goals raises scientific interest and updates solution of tasks, which should help to improve management in construction.

### **Tendencies in the construction sphere due to the use of information-communication technologies**

Today widespread use of ICTs and the Internet in the global socio-economic and organizational-administrative activities of people and organizations have led to the emergence of evolutionary forms of social relationships, the nature of which is peculiar to the emergence of a completely new type of economy.

The emergence of economic organizations in the form of integrated associations, interacting with all stakeholders (community, the state, the world) to implement and achieve common goals, became a convergence of private and government sector with generation of big business to create large-scale projects and achieve benefit of the society and the state.

The study of factors and the nature of relationships in these associations drew such conclusions [1]:

- An objective need for this type of cooperation (association) for the state and for companies has appeared.

- These associations are the organizational form of management, on which basis development is associated with the creation of business structure.

- Integration of subject's resources (investors, private companies, state) leads them to solve common problems of the business alliance to achieve its objectives.

The formation of such business alliances as the BACS caused by changes of the organization's environment where the globalization of markets and the improvement of business methods and technologies have a direct impact on these processes.

The paper [2] identified an innovative mechanism that is required for MVBE for adequate InfoCom-System of management. This mechanism meets modern tendencies and takes into account the requirements of coherence between all industrial and economic actors of the considered business alliance. The advantage of using this mechanism is that it [2, p. 550]:

- contributes to the improvement of the organizational structure (providing innovative mechanism structure of the economy by the introduction of modern management information systems (automation and mechanization) and ICTs, as well as increasing the qualification of experts);

- minimizes or prevents many of risks faced by the economic system;

- stabilizes the activity processes of the integrated subjects;

- adapts quickly integrated structures of generating innovation management processes to processes of implementing such innovations;

- contributes to the sustainability of association's activities in all the scale of appropriate MVBE.

### Features of the construction sphere business association's management in terms of material-virtual business environment

Changes in the socio-economic conditions and organizational-managerial processes caused by modern standards take into account the peculiarities of knowledge (network, information) economy forcing organization to go beyond the boundaries of traditional management. Today, the proper use of knowledge with relevant ICTs, InfoCom-means, -systems and -networks is one of the main sources of competitive advantage and sustainable development of economic enterprise structures (EES) under MVBE in construction sphere.

Of course, the involvement of InfoCom-interconnections for effective interaction of all participants united in MVBE's business processes becomes the basis of effective BACS's management performance. All the included EESs must be managed in a new way, with the use of advanced techniques, to improve economic-administrative activity of the socio-economic system (unlike to traditional methods) by applying innovations to the management system based on ICTs.

In modern conditions question of infoCom oriented organizational-managerial innovations is particularly relevant. This implies the effective implementation of management of available adequate and relevant knowledge-based InfoCom relationships in EESs under MVBE. Important aspects of BACS's management innovations are [3, p. 566]:

- Willingness of BACS's employees to shift to a new way of thinking for a successful problem resolution, for the implementation of management and for solution of internal production targets.
- Positive attitude of the company's staff to innovations.
- The willingness and determination of the administrative staff in relation to the upcoming risks and emerging issues for the formation of a new type of organizational culture.
- Willingness of BACS's management to resolve possible conflicts in the relationships of internal and external environment in the formation and development of MVBE's infrastructure.

It is worth noting that the competence of all participants of BACS's business processes is of great importance because a joint economic space with InfoCom-environment through ICTs contributes to the formation and development of the network society and

leads to the pooling of such resources in terms of MVBE as:

- Material.
- Labor.
- Technical.
- Energy.
- Information.

In connection with this search, accumulation, systematization and acquiring of relevant knowledge by each employee in EES from incoming information are prior for resolving arising problems. In turn, the main problem is in the availability of such intangible resources and that, in particular, technical and technological knowledge quickly become obsolete. Hence, knowledge is the most important resource in ordinary use of ICTs and InfoCom-means in business associations. Therefore, transformation (analysis) of existing knowledge and information coming from MVBE forms and generates new knowledge, which is a priority for managers and employees for creating innovations.

It is important to emphasize that one of the main conditions for effective management system operation is competent use of appropriate ICTs to achieve a competitive advantage in the BACS under MVBE. Moreover, new knowledge is acquired in order to overcome the cognitive limitations in the resolution of arising innovation problem (IP), which is necessary for the BACS's managers to mark out.

As a result, managerial innovations in connection with the designated above problem are to ensure implementation of proper interactions by dint of interactions of all EESs within the borders of BACS based on use of ICTs. However, manager's timely revealing of such arising in BACS's business processes IP and making effective management decision should be implemented on the basis of new conceptual management positions in MVBE. The main features of the problem were reported in paper [4].

According to a study [3] on the development of management in construction sphere with the use of ICTs, a key point in the implementation of the result to solve the problem of effective relationships between members of BACS was highlighted. At the same time it was noted that the ability of the EES's staff in purchasing, ordering, and the formation of obtained strategic knowledge in hierarchical order of the relationships between EESs consists of [3, p. 571]:

- 1) InfoCom-Systems with skills and technology of knowledge acquisition and

integration by the all employees of business associations under MVBE;

2) a hierarchical structure where sectors of special knowledge with ratio employee-to-employer in each EES are identified;

3) hierarchy of production processes correlated with the complexity of solution and market value of performing research on this production problem resolving;

4) the level of knowledge accumulated by all employees of InfoCom-integration.

It is worth emphasizing that in paper [3] was also highlighted peculiarity in the search of effective interconnection with the help of knowledge based on the use of ICTs through InfoCom management system to enhance the level of cooperation of EESs in BACS under MVBE for their work in achieving common goals. In our view, these management innovations with the ensuing problem situation or IP must meet such requirements of innovative management and proper actions, assistance and interaction in MVBE as [3, p. 572]:

- The search for new potential relationships in MVBE.
- The search for new BACS's inner resources.
- Revealing of new potential opportunities together with several units or departments.
- Effective management of all BACS's staff considering the use of their knowledge.

All this requires from the person making the decision (PMD) efficiency in the use of integrated knowledge of all BACS and implementation of adopted on the basis of their effective management decisions. Moreover, the management association of EESs under MVBE for purposeful functioning, sustainable development of integrated organizational forms of management, the successful implementation of strategic, tactical and operational management should systematically identify, develop and subsequently apply effective exposure using InfoCom-system at all stages of the goals and solving problems by applying innovative mechanism in the business processes of the construction [4, p. 44]. Therefore, BACS's management accurate knowledge about the structure and composition of it's EESs may in the event of IP involve required employees to various processes. Thereby, individual and collective effectiveness of the EESs improves through the acquisition of advanced knowledge.

In turn, the EES's staff, who assimilate information interpreting it in the relevant knowledge, is endowed with the ability to:

- Retrieve information.

- Identify new challenges in business processes of BACS.

- Regularly reproduce acquired knowledge and, thereby, be the bearers and disseminators of advanced knowledge.

- Learn new solutions and incorporate them into their business processes.

- Apply this knowledge, methods and technologies.

**Managerial innovations with the use of information-communication technologies for the management of the business associations of the construction sphere in terms of material-virtual business environment**

As our research shows to an increasing degree management of BACS under MVBE with the dynamics of occurring within it's boundaries interactions should structure knowledge about competencies of EESs and their staff to implement effective administrative decision upon a problem situation or IP. It is necessary to take into account the need to implement this in the limits of the formation processes of maintaining and developing the proper organizational culture. Such organizational and cultural environment will systematize administrative procedures to facilitate coordination interactions to resolve problems. Therefore, you should also note the need to motivate employees to acquire knowledge, which depends on the development of organizational culture. Consequently, the ability of BACS's management system to ensure the greatest possible acquisition and operational knowledge transfer between EESs under MVBE is one of the priorities for the high probability successful resolution of ensuing IP.

By acquiring and assimilating knowledge each EES of BACS aspires to perform a time-consuming and expensive business process. Thus, it increases their profitability and makes due contribution to the success of the entire BACS. This is the main motivating incentive for all participants of the BACS.

According to a study [5] for the entire organizational system of BACS proper management with the ability of effective adoption and making administrative decisions in the conditions of EES's influence with the use of ICTs in the corresponding MVBE is required.

As a result of research taking into account hereinbefore explained a number of benefits has been identified, for which the

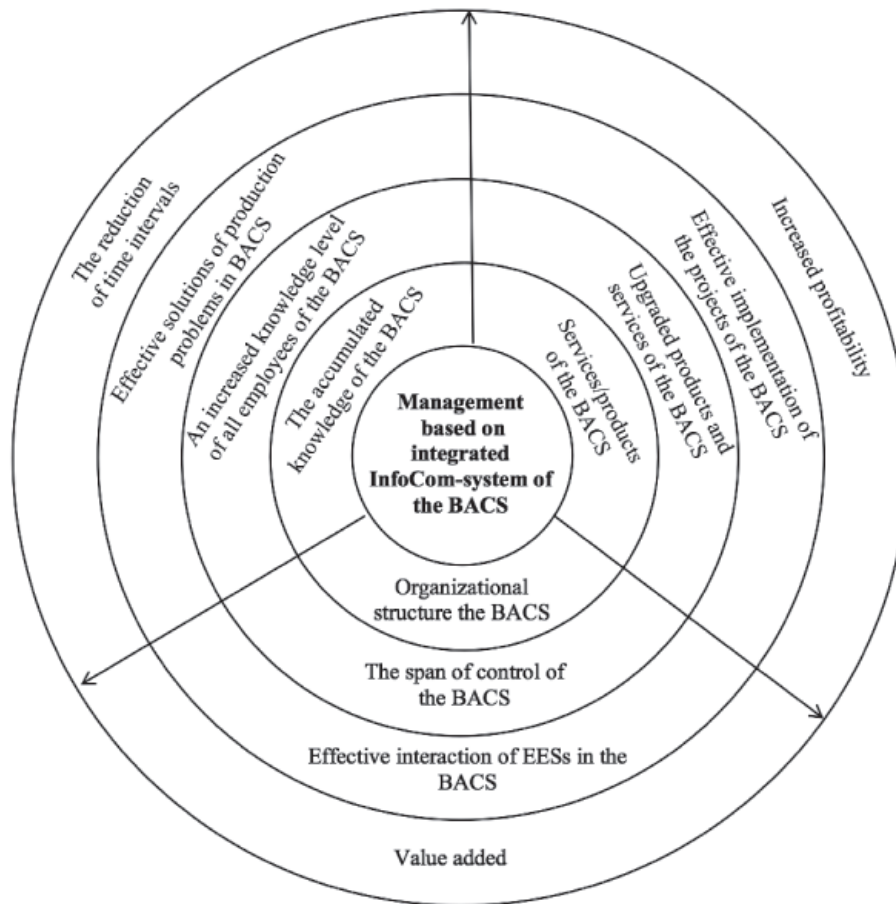

Diagram of components of the result of effective solution of BACS's production problems with the use of InfoCom integrated systems [5, p. 40]

interaction with InfoCom-system takes the following form [5, p. 37]:

- EES performs the production process and in the course of implementation makes the database object proposals for a possible correction;

- EES in real time can watch how the management decision is implementing and to introduce amendments into their production processes according to the results of management influence;

- management by monitoring the performance of work at all stages of the construction by all the participants of the construction site with the help of ICTs allows BACS's management continuously track the use of resources, materials and equipment, as well as the actual weather conditions and other numerous variations and risks.

In conclusion on this publication we note the following.

1. The use of the above stated management practices can help managers of organi-

zations of the construction sphere to restructure its activities in accordance with new requirements to the formation of an effective management system using the capabilities of information and knowledge impact on the participants of the business processes with the use of ICTs. Thus, competent implementation of considered here innovative management actions leads to a qualitative shift in the organizational structure in the form of effective relationships and interactions in the industrial, socio-cultural and economic-administrative BACS's processes. This type of management produces innovative organizational culture [6] based on the effective resolution of BACS's production problems with the use of InfoCom integrated system.

2. Considered innovations of BACS's management take into account InfoCom direction and effective implementation of control functions with adequate and relevant knowledge for realizing targeted interrelated interactions. This forces the modern

business associations to operate in MVBE with appropriate scale-space InfoCom mediated interactions in real-time. In turn, such modern business association as a socio-economic system made up of elements (EESs) realizes all stages of building production process with a strong integrated nature of the partnership through interconnected InfoCom-means and ICTs. At the same time it is possible to integrate intellectual-creative potential and knowledge of the BACS's participants.

3. It is the use of integrated knowledge of all business alliance for the development, adoption and implementation on the basis of their effective management decisions may lead to the improvement of the BACS's quality management system activities with competent use of proper network of relationships in the InfoCom-system.

The result of efficient production through the use of stated knowledge is the appearance of added value by reducing time intervals between stages of production processes [5, p. 39].

In our opinion, such an application of knowledge in making and implementing man-

agement decisions with the use of ICT leads to efficient production processes (Figure).

#### References

1. Kunyaev N.E., Martynov L.M. Genesis and tendencies shaping today's business associations // *Economy and Entrepreneurship*. – 2015. – № 5 (Part 1) (58–1). – P. 930–935.
2. Kunyaev N.E., Martynov L.M., Yatsenko V.V. Tendencies of development management in the construction sphere in today's business environment with the use of information-communication technologies // *Economy and Entrepreneurship*. – 2015. – № 8 (Part 1). – P. 548–554.
3. Kunyaev N.E., Martynov L.M., Yatsenko V.V. Features of management in the construction companies with the use of information-communication technologies // *Economy and Entrepreneurship*. – 2016. – № 1 (Part 1). – P. 566–572.
4. Kunyaev N.E., Martynov L.M. Features of modern management associations of construction companies in terms of the material-virtual business environment // *Proceedings of the XXI-th International scientific conference "Actual problems of modern economic science"*. – Lipetsk, 21 August 2015. – P. 40–45.
5. Kunyaev N.E., Martynov L.M. Improvement of management systems of business associations of the construction sphere with the use of information-communication technologies // *Economy and management control systems*. – 2016. – № 1 (19). – P. 34–42.
6. Martynov L.M. Methods of formation of organizational culture of enterprises, which apply InfoCom Management // *Russian journal of scientific publications*. – 2014. – № 1 (21). – P. 22–24.

## SCIENTIFIC AND EDUCATIONAL COMPONENTS WITHIN THE PROCESS OF SUSTAINABLE GARMENT DESIGN AND TECHNOLOGY DEVELOPMENT FOR PEOPLE WITH DISABILITIES

Tolmacheva G.V., Gerasimova J.L.

SEE HPE «Omsk State Institute of Service», Omsk, e-mail: rector@omgis.ru

The goal of the given project is the formulation and research of the issues which belong to a field of integration and rehabilitation of people with disabilities. The main focus is the social adjustment in the process of design education within the context of the discipline of "Costume and Garment design". It deals with the mission of designing comfortable products for people with disabilities, covering the educational, scientific and ethical aspects of design in its relevance and significance for the modern community. The introduction of the disability related projects and tasks into the educational process of teaching or research work enables to resolve various problems in complexity covering not only the field of both ethical and aesthetic matters but also practical application of design and technology. In the process of studying the subject and setting on the project objectives physical disability is considered a social phenomenon. The study is aiming to provide both the ways of targeted professional group care for people with disabilities who share similar psychological characteristics, specific changes in the body, or devices for rehabilitation, as well as bespoke production of items and capabilities of people with disabilities for selected individuals with specific disabilities. Several concept design directions are formed to provide the grounds of research and fulfillment of the given task: the concept development of the body – friendly garment interaction for people with disabilities; concept of environmental protection, which allows to adapt garments to the various environmental conditions; the concept of comfortable individual friendly fabrics outsourcing, patterns development, cozy trimmings and finish technology and fabrics designed for people with disabilities; concept of anesthetization of the deformed body parts; the concept of "friendly" color.

**Keywords:** design, design education, adaptive design, clothes, disability, comfort, project development, social integration, adaptation

Modern standards of higher and postgraduate education are introducing a high level of requirements for the implementation of basic educational programs. As well as organizing the formation of professional competencies, they also put forward a necessity of creation of the conditions requested for individual's socialization within the educational environment. It is highly important to form a comfortable socio-cultural environment that enables the development of social interactions, within systematic nature of activities in educational process.

In a civilized multicultural society sex, ethnic, subculture and linguistic minorities have the right not only to be "equal", but also to ensure that they maintain their "individuality" [1]. Modern cultural critique suggests that the idea of the body "norm" is artificially constructed, like the concept notion of the racial or sexual norm [2]. This shift towards improving the aspects of social interaction within the education process is a direct reflection of the changes happening globally, targeted to change the core approach of individuals towards themselves. It is believed, that the transformations that have taken place within in all the areas of modern development: within the economy, technology, and social structures, had enabled individuals to obtain a new social position, especially in relations to other people and to themselves.

According to D. Feldshteyn, the professor of REA, due to the expansion of social contacts caused by the growth of migration, a modern

individual nowadays has a new approach to perception, understanding, exploration and the analysis of the world that he has changed. The world keeps changing the individual as well, because it is two way process. This is manifested at various levels of human existence: physiological, psychological and social. It objectively is leading to an increase of social activity of the people, their deeper reflection on others and themselves. That provides the restructuring of mentality, a shift in major goals, values and orientation of individuals. That forms new social needs and new opportunities for their realization [3].

Many scientists research and depict core features the modern men's behaviors. Within their research they observe, for example, the lack of responsibility, increased anxiety, aggression and other qualitative changes in interpersonal, intergroup relationships, in relation to the various circumstances of life.

Any higher education facility should be interested in the healthy socialization of the individual graduates and can create an environment for its successful maintenance. The more emphasis is put towards successful socialization, the more important it becomes to improve the educational component in many disciplines of the core educational programs. Specialists at the Department of "Costume Design" of Omsk State Institute of Service approached the issues of socialization of their students from the perspective of combining social, scientific

and educational processes. They focused their interest in the aspects that strengthen the relationship between the design part of the educational process and communication activities. In terms of the educational and research process, it acquires a new strategic perspective.

The structure of the higher education facility has specific features in its current condition. The older generation, socialized through its own experience, which was formed by the ideology of socialism is trying to influence the generation of pure individualists. This new generation finds its own perspectives in the "enrichment" of individuality, aiming to develop character traits necessary for independent living, the establishment of the individual "I", the conquest of a particular social position and realization of themselves in it [3].

Generally, the active period of undergraduate and postgraduate academic study may influence the formation of an active consciousness in the growing person. Students encounter the role of socially responsible entity's that can take responsibility not for themselves only. They show the responsibility in a common effort, sharing the common cause and providing services for other people. Within the walls of the higher educational facility we are dedicated to the goal of forming the new generation of people. Current graduates are the next generation to build up the relationships within the community, which will have a modern approach to the problem of socialization and integration of disabled people into a socially meaningful environment.

Domestic and foreign researchers of the social integration for people with disabilities, emphasize the point that disabled people with a positive and confident "self-concept", who are "psychologically well-off" are more positively perceived by others within the social interactions.

Psychological well-being depends upon the communication-friendly environment and active social adaptation. So, the student community may contribute to the formation of psychological well-being for "young people with disabilities". According to sociologists and psychologists, young disabled individuals are a "tin-canned" demographic resource. Their successful rehabilitation within the college community can positively improve their social integration [4]. It is believed that, disability is not only a medical, but a social phenomenon. In modern Russia – who keeps its distance more: people with disabilities from the rest of the society or society from them? People with disabilities and their close entourage in many cases had to shape their own social environment, where they are banned or willingly remote themselves from the world of healthy people.

Modern society is moving towards finding productive means to overcome a social division [5].

General areas of assistance provided by the State of Russia for people with disabilities are: healthcare support; legal and financial support; medico-social and vocational rehabilitation; disabled public access; education; employment; media campaigns promoting positive and friendly attitude towards people with disabilities.

Possibly, to provision of more individual care will be even more effective. Perhaps, communication with specific individuals, assistance with smaller, not global, but personally important issues, can raise the level of motivation for rehabilitation in disabled individuals. It can encourage their personal desire to increase the degree of their social and psychological adaptation, and change their self-image and the perception of their disability as less dramatic and challenging, to form an optimistic approach.

People with disabilities may receive support and encouragement from their peers – through communication, bringing together young people during various social events that provide both material and spiritual involvement and care. Not only healthy people should understand the issues of disabled people and learn to treat them as equals or provide positive encouragement and assistance when needed, but also people with disabilities have to overcome their own acute sense of isolation, inferiority, negative self-differentiation from the others, and master the art of communication. Joint efforts of sociologists, psychologists and teachers are necessary for the urgent development of specific educational programs in this area [6].

Our creative project aim was to create comfortable garment products for people with disabilities. Selecting that project we have put together the aspects of ethical, educational and scientific components of the course of design engineering. A researched group of handicapped individuals was matched by the criteria of presence of similar physical disabilities, similar psychological characteristics, specific deformations in the body frame or assistant devices necessary for rehabilitation. That had enabled research team to form to the research base of case studies. The introduction of such case studies in the educational process, or scientific work, in all its complexity and social importance cannot be compared to anything else.

The first thing that was taken into account was the notion of how difficult it is for healthy young people to overcome a culturally

formed distance and remoteness that they developed towards people with disabilities. It's a challenging request for disabled people as well. This requires special psychological training. Positive communication skills and ability to overcome a syndrome of the "foreigner" (other) is essential. Every culture in the process of its historical development creates a vision of the healthy, beautiful body. Deviations from a predetermined standard are perceived as "abnormal" in the society. According to the existing mechanisms of social perception ("Halo Effect" by a factor of "Superiority"), there is always a chance to trigger a process of "stigmatization" of disabled people ("stigma" – conspicuous sign of pathology). I.e. the stigmatized individual with "atypical" external appearance is often associated with negative psychological qualities. Social "stigma" becomes an additional limiting factor to the life of the disabled individuals, causing them to obtain a passive social role [4].

The process of designing comfortable attire for people with disabilities starts with a series of lectures and practical training for both students and professional team provided by the crew of psychologists that gives them necessary communication skills that help making interactions with disabled people easy and less stressful. Both students and teachers research the experience of positive communication with disabled people both individually and within bigger groups.

It's very important to learn how to empathize, and to be attentive and tolerant to the needs of disabled people, but at the same time to sustain equal and positive relationships based upon respect and politeness. It does not come easy for people with little interpersonal experience of communication with disabled people; it takes time and mental effort and personal involvement into a process.

Second thing that is important during the process of designing products for people with disabilities is to solve different tasks in complexity of combining design and ergonomics. For future designers in most cases it's an individual research and creative work path that requires not only the suitable and tasteful aesthetic decisions, but a specific level of professional skills in pattern engineering. The aim is to provide assistance in organization of a more comfortable environment, more comfortable outfits exclusively personified and designed for those abnormalities that characterize the degree of disability of each researched individual. Womenswear and menswear designers can design bespoke outfits, which, taking into account individual features of each handicapped person, can help a person with disabilities to adapt more comfortably to the environment.

General recommendations and design projects are only possible for the groups of people sharing common signs of the same physical abnormalities, such as assistance in scoliosis correction, or creating comfortable costume details and accessories for wheelchair users.

In most cases, designing comfortable clothing and accessories for handicapped people requests a designer to follow up individual needs of each disabled individual. That means bespoke approach to design and technology of a garment. Unfortunately, nowadays, not all people with disabilities can get easy access to the designer's assistance. So, introducing the initiative from the students and professional team in that a project, in a sense of morality and empathy, is the sign of goodwill to the people who happened to have physical challenges.

Development of the projects that are related to the design of highly comfortable clothing specified for people with disabilities has a scientific and educational value at the same time. Analysis of various design aspects, search options and the selection of appropriate materials, forms and methods of their use is the proper way of researching that topic. The whole range of activities within the process of education – gives all of the agents of the educational process such valuable social and individual experience and shapes student's levels of tolerance, compassion, and awareness of other people's "impossibilities" and physical challenges.

When a designer is working on adaptive design project, all the conditions are important, as elements of the system are interconnected and can affect the final result of the creation of a new product. This involves the use of interdisciplinary knowledge and skills, aesthetic and scientific cooperation within the product design industry.

To form specific situational tasks and the definition of concepts, throughout the research process we identified core groups of individuals bearing shared physical or psychological abnormalities. It has shaped out several concepts of work provided below:

1. *The concept of garment's interaction with specific physical needs of disabled individual's body frame* (ways of putting on the garment, comfortable bindings, supporting design constructions, garments with ability to transform, special design constructions, specialized systems of allowances to allow the freedom of encirclement and movement).

2. *The concept of environmental protection* (clothing and accessories that increase comfort and protection from the aggressive environment for the handicapped individual).

3. *The concept of "caring" or a "body-friendly" technology* (seamless technology, soft-taped seams, lightweight materials).



4. *Concept of adding positive esthetics to the defects of the body* (body conscious decoration: tattoos, prosthetics, accessories, add-ons).

5. *The concept of "careful" colors* (the healing qualities of color, symbolic system of colors, chameleon colors).

Scientific and technological advances have increased the life expectancy of people with disabilities; nowadays they have a chance to be more mobile, reducing the level of their dependence on others. Internet technology and inclusive approach had increased the possibilities of communication and education for disabled people. These improvements cannot be ignored. The newly obtained ability to communicate, ability to work in teams, puts out a new issue that includes external and visual communication. There, in many ways of professional interactions with undergraduate students that has a positive impact. Young and active undergraduates, who are ready to face new challenges positively, who are open for productive interaction with people who are somehow different from the others, are the ones we focus our projects on. Design students can multi-

task: think, decide, and give a fresh perspective upon both creative journey and ergonomic comfort and convenience within the specified product development. They are also a moving force in creating a positive impact the life of people with physical challenges.

#### References

1. Rogers M.F., Ritzer G. (Eds.). *Multicultural Experiences, Multicultural Theories*. – New York: The McGraw-Hill Companies Inc., 1996.
2. Surber J.P. *Culture and Critique. An Introduction to the Critical Discourses of Cultural Studies*. – Boulder: Westview Press, 1998.
3. Feldstein D. *The Man in the Modern World: Opportunities For Development // Academic Gazette Institute for Adult Education*. – 2009. – *Man and Education* № 3 (20) – P. 10–16.
4. Shentseva N. *Descriptive Model of Socio-Psychological Rehabilitation of the "Young People with Disabilities" / N. Shentseva; A. Davydov // Scientific Dialogue*. – 2013. – № 4 (16): *Psychology. Pedagogy*. – P. 85–95.
5. Shaburova A. *Availability of the Urban Environment for People with Disabilities / A. Shaburova, L. Fahradsava // Questions of Territorial Development*. – 2014. – № 3 (13). – P. 1–7.
6. Dobrovolskaya T. *Social and Psychological Characteristics of People with Disabilities and Healthy Relationships / T. Dobrovolskaya, N. Shabalin // Sociological Studies*. – 1993. (electronic resource). – № 1.

## Materials of Conferences

**FRACTURE SURFACES  
UNDER PLASTIC DEFORMATION**

Udaev V.V., Frolova T.A., Frolov S.V.  
Tambov State Technical University, Tambov,  
e-mail: frolova@mail.gaps.tstu.ru

Increasing the strain energy effects on the surface of the component leads to a transition from elastic to plastic deformation. Formation of the minimum residual deformation begins when the surface layer of the metal yield strength ( $\sigma_T$ ) and requires the application to the unit volume of the energy exposure, corresponding OBE area under the curve (Figure).

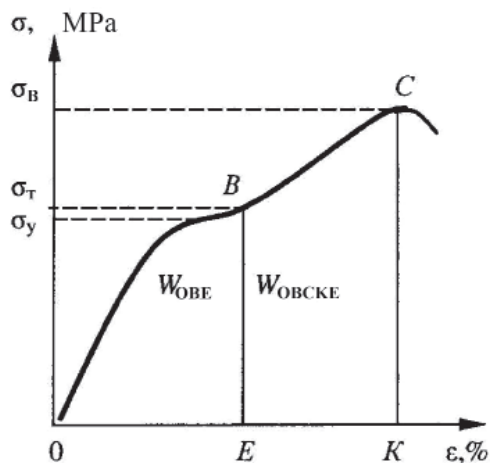

Changing the energy of plastic deformation in tension

Limit the degree of uniform plastic deformation occurs at voltages equal to the tensile strength

( $\sigma_B$ ) materials. Creating this level of stress state requires strain energy cost equal to the area under the curve OBCKE.

Increasing the degree of loading of a metal volume of the surface layer above the yield stress at the time of the contact leads to the formation of plastic deformation-malized zones. Repeated loading of these areas are subjected to re deformation that amplifies motion of dislocations in the process, not only the surface layer but also in the metal. With the increasing number of cycles of concentration in the deformed metal is increased and at the same time hindered the output of crystalline structure defects on the surface of the product. The lower the coefficient of hardening during plastic deformation, the metal is more ductile, especially stage can be prolonged exposure to the external force beyond the yield stress. Achieving the ultimate degree of hardening on the material with the higher coefficient of hardening occurs at lower values of the plastic deformation. Strain hardening during deformation fades. This is because the maximum possible dislocation density does not rise above. At this limiting level, the emergence of new dislocation balanced by the number of endangered dislocations as a result of their output to the surface and annihilation. Resulting in the process of plastic deformation in some parts of the accumulation of dislocations, which is close to the limit level, accompanied by the formation of the embryonic fissure.

The work is submitted to the International Scientific Conference «Modern high technologies», Czech Republic (Prague), May, 10–16, 2016, came to the editorial office on 20.04.2016.

*Short Reports***RESEARCH OF METHODS  
OF PARAMETRIC OBJECT CHANGES**

Vadutova F.A., Cherkashina Yu.A.

*National Research Tomsk Polytechnic University,  
Tomsk, e-mail: cherr999y@mail.ru*

The purpose of the work is the development of program algorithm for objects morphing on the basis of current methods of basic bodies' parametrical change. The article carries out the analysis of current methods of objects' morphing and their realization at the program level. An algorithm of the morphing library work was developed.

**Introduction**

With development of the three-dimensional (3D) graphics, there are a lot of tasks where the morphing of objects according to developer's requirements can be applied. It includes a sphere of animation, an online application with three-dimensional visualization and a game industry. For example, the modern industry of the computer games and animation makes high demands to realness of the environment representation, an individualization and specification of animated characters. To realize these requirements it is necessary to perform a large amount of works which will demand the considerable expenses of resources that will lead to decrease of the product competitiveness and of the project profitability.

Today, it is possible to distinguish some main approaches to the creation of 3D models of objects, offered today in the most successful 3D programs – schedules: the creation of solid bodies by means of Boolean operations – by addition, subtraction or crossing of models material; the formation of the composite polygonal surfaces, which are called as a Mesh-surfaces, by polygonal or NURBS modeling; the use of geometry modifiers. There are the main organizations using these techniques in its products: Autodesk, Dessault System, Unity and others. The programs Autodesk 3Ds Max, Autodesk Maya, Unity 3D work with objects of the different type, including the polygonal grids to which the term “morphing” is directly applied.

Let's give the definition of the concept a morphing. Morphing is a smooth transformation of the image of one object to another. One of the tasks, where the object morphing is successfully applied, is the creation of game characters with different external data. For this purpose to the developer will optimum work with a basic body, what in the professional environment is called “primitive”. Setting parameters for morphing, the developer will receive a number of the same objects, unique on the external data, for example, game characters, and won't spend much less temporary resources.

One more example of the task where an online object morphing is successfully applied, it is, so-called, “the 3D – fitting rooms”. The essence of the operation of such application is that the user, having intuitively clear interface, enters parameters of his body, thereby editing the basic object, in this case 3D-dummy, under individual parameters, and after this tries on the three-dimensional clothes preparations provided by known trademarks. The application allows to estimate the product appearance on the user's body, and also to pick up an appropriate size. Use of such application on the site of the producer increases online sales and considerably minimizes risks of the goods return.

The direction of modules integration on an object morphing in the real-time mode develops in Russia since 2011. Corporations carry out orders to the research centers for the software product development to improvement the content quality that they can use for visualization of practical material in internal and external activity. Orders arrive from versatile representatives, among them automobile consortia, marketing services, textile productions, and a raw segment of the Russian business. Developers use various ways to execute the module most close to the mortgaged requirements. Working on the subject domain analysis, it becomes clear that there is no universal utility at the moment. Existing software products are applicable only in the specialized areas.

**Objects morphing and its realization  
at the program level**

It is difficult to find issued in the book information about of parametrical objects morphing at the moment, Actual information can be found at specialized forums of programmers, often foreign, or in personal contact with the practicing experts. We will begin with definition of Morphing, as process.

Morphing (Morph) is a process of transformation of one object to another, by means of object's tops provision changing. Editing of the polygonal objects can be made both at the level of object in general, and at the level of subobjects: sides, edges or tops. Prom it depends on what algorithm of work will be applied for morphing. The real secret of combined transformations use is the announcement of a reference mesh in the equation. The basic mesh (basic object) determines the initial coordinates of each top in a mesh before morphing application. Often the basic mesh is the initial mesh of morphing operation. In an example of the person face mesh the person face with the closed mouth and open eyes is basic. When you combine two morphing meshes (or any quantity meshes), you define a difference of tops coordinates of the each morphing mesh and the basic mesh. You unite these differences of coordinates in the resultant combined morphing mesh.

The morphing can be applied to net objects, patches or NURBS surfaces. Further, we will consider a net morphing. However, its principles are uniform for objects of any origin. A necessary condition of the objects morphing creation – is the preservation of number of tops: it has to be the same, as in inoculating object. This results from the fact that operation of a morphing simply moves the inoculating object's tops that they coincided with the corresponding tops of object-purpose. If the number of tops changes, the morphing doesn't work.

Polygonal grid (slangy “the mesh” from English “polygon mesh”) is a set of tops» edges and sides, which define a form of many-sided object in three-dimensional computer graphics and volume modeling. Sides usually are triangles, quadrangles

of the operations performed over grids can include Boolean algebra, smoothing, simplification and many others. Different representations of polygonal grids are used for the different purposes and appendices. For transfer of polygonal grids network representations' on a network, such as “stream” and “progressive” grids are used. Volume grids differ from polygonal in that they obviously represent both surface and volume of structure whereas polygonal grids obviously represent only surface, but not volume. As polygonal grids are widely used in computer graphics, algorithms of beams trace, detection of collisions and dynamics of solid bodies are developed for them.

Mathematical equivalent of polygonal grids is unstructured grids.

Basic spatial forms are: parallelepiped, cone, sphere, torus, wedge, cylinder (Fig. 1, 2).

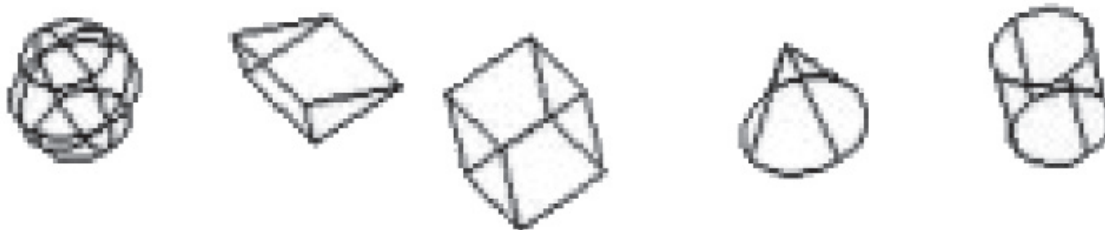

Fig. 1. Basic spatial forms

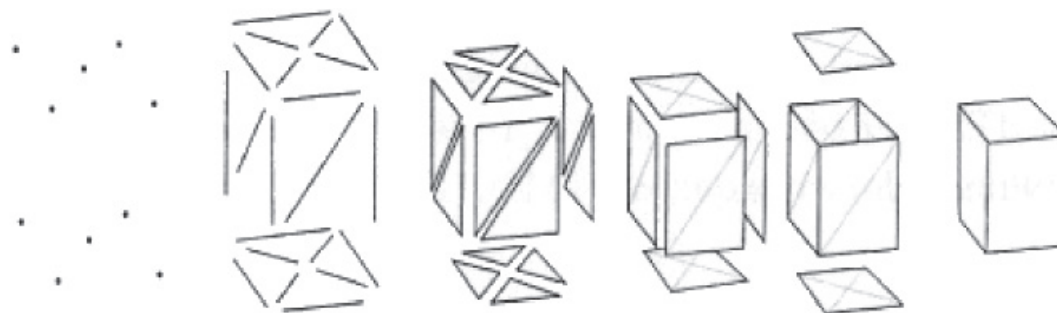

Fig. 2. Elements of polygonal grid modeling

or other simple convex polygons (grounds) as it simplifies visualization (rendering), but grids can also consist and of the most general concave polygons, or polygons with holes.

Work with polygonal grids – is big subsection of computer graphics and geometrical modeling. The set

The objects created by means of polygonal grids have to store different types of elements, such as tops, edges, sides, grounds and surfaces. Only tops, edges and either sides, or grounds are stored in many cases. The top is a position together with other information, such as color,

a normal vector and coordinates of texture. The edge is a connection between two tops. The side is the closed set of edges in which the triangular side has three edges and quadrangular – four. The ground is a set of sides.

In systems, which support multilateral sides, grounds and sides are equivalent. Mathematically, the polygonal grid can be presented in the form of an unstructured grid, or the nondirectional count, with addition of properties of geometry, a form and topology.

Usually for a grid are defined materials, which allows different parts of grid to use different shaders for rendering. The majority of the grid formats also assume UV coordinates which are the separate two-dimensional representation of a polygonal grid developed to show, what part of two-dimensional texture is applied to different grounds of a grid.

At the program level, polygonal data can be stored and transferred in various formats: \*.3ds, \*.stl, \*.obj, \*.x3d and so on. Each of them has the advantages and shortcomings. Generally, the char-

acteristic of this or that format depends on the program parent, the volume and contents of file's data, and depends on compatibility with other software products. According to skilled data the \*.obj format has the optimum characteristic to assume it as a basis the developed library.

A Java/JNI part of the JNI interface and a set of java classes. Classes Morpher and MoiphObject – java wrappers for JNI interface. Class MorpherError contains the error codes.

#### References

1. Samarskii A.A. Mathematical modeling and computer experiment // Journal of Academy of Sciences of USSR. – 1979. – № 5. – P. 38–49.
2. Semyanihina Ya.Yu., Kalinowski N.V., Davydov B.A., Vadutova F.A. Morphing parametric objects, A collection of articles XII All-Russian scientific-practical conference of students, graduate students and young scientists “Microsoft technologies in the theory and practice of programming”. – 2015.
3. Arkhipov O.P., Maniacov Yu.A., Sirotinin D.O. Morphing method of registration of three-dimensional object on the basis of full-scale experimental data // Systems and tools inform. – 2010. – Vol. 20, Issue 1. – P. 91–105.

*Materials of Conferences***SYSTEM PLANNING AND MANAGEMENT OF SHUTDOWN MAINTENANCE FOR CHEMICAL FACILITIES**

Egorov S.Ya., Shirokova S.D.,  
Egorov E.S., Betin E.A.

*Tambov State Technical University,  
Tambov, e-mail: egorovsy@yandex.ru*

The aim of the work was to develop operational planning and control system for shutdown maintenance of chemical facilities. The importance of the problem is related to the large monetary losses due to during production due to equipment downtime during shutdown maintenance [1].

The system under consideration includes four subsystems: the collection and processing of initial data; planning and management; supply of spare parts; issuing of documentation.

Subsystem for collecting and processing of initial data provides a baseline data collection and processing of initial data for the initial construction, calculation and optimization of the network model, and for the rapid adjustment of the calendar plan on the stage of operational management.

Subsystem for planning and management is a set of graphical and computational methods, organizational measures and monitoring techniques which provide modeling, analysis and dynamic restructuring of the plan which is needed for complex projects and set of work realization. Realization of the planning and management functions of the set of work is carried out on the basis of construction, analysis, optimization and periodic updating of network models. On the basis of individual work mod-

els the generalized network model of all repairs in general is constructed and calculated. In the capacity of optimization problem criteria of the network model the following is used: capital repair costs, salaries of the repair person-la; the time of repairs; the variance of resource changes; the sum of the squares of the needs in resources.

Subsystem for supply of spare parts quickly recalculates the network model of repair works in dependence on the supply of one or another spare part.

The issuing of documentation includes: a schedule of shutdown and capital maintenance, a schedule of spare parts and components shipment; specification of works; statements of labor costs.

The final product of the system: identification and mobilization of material resources and time reserves which are hidden in irrational organization of the production process; project management with prediction and elimination of possible failures; improvement of the technical performance of the project; efficient management. The economic effect from the use of the system is 8–20 percents, depending on the complexity of the shutdown maintenance.

**References**

1. Egorov S.Ya, Kartashov A.S. Development of the system for calendar planning of shutdown maintenance // Repair, restoration, modernization. – 2006. – № 12. – P. 24–31.

---

The work is submitted to the International Scientific Conference «Production management and natural resources», France (Paris), March, 19–26, 2016, came to the editorial office on 04.03.2016.

*Materials of Conferences***PECULIARITIES OF MODERNIZING  
RUSSIAN ECONOMY**<sup>1</sup>Danilina E.I., <sup>1</sup>Chebotarev V.E.,<sup>1</sup>Gorelov D.V., <sup>2</sup>Malikova Y.I.<sup>1</sup>*Moscow Institute of Public Administration  
and Law, Moscow,**e-mail: danilina05@mail.ru, dvgorlov@mail.ru;*<sup>2</sup>*Vologda State University, Vologda*

The article studies peculiarities of domestic economy, its transition towards informational form, it demonstrates foreign experience and grounds the necessity of a new model of growth for creation of knowledge management system.

As we know, the basic content of economy modernization is increase in quality of state economy regulation, but not neutralization of it. Foreign economists criticize radical-liberal ideas of “Rayganomy” that does not consider human capital as a foundation of new economy, change in capital structure, transition towards network methods of business organization.

In South Korea and China volume of micro-electronic components’ output in 300–500 times greater than the same index of Russia, and 4–5 times greater than volume or automobile production of oil consumption. During the recent 20 years 2–3 generations of technological equipment has changed. Microelectronic digital technics forms up to 85% of value in the newest equipment, and an average apartment hold over 40 operating microcontrollers, and average automobile – over 30. Russia has to import over 80% of electronic devices, including those of military purpose. A number of countries limits sales of certain types of microchips to Russia.

Russian economy has approached a transition point. The operating liberal economic strategy is aimed for macroeconomic stability, decrease in inflation and budget deficit. It is achieved through withdrawing money from economy, investing export income into reserve and debtor responsibilities of other state, increase in corporate debt, redistribution of education and healthcare financing into local budgets. Within globally unstable and turbulent economy this strategy has decreased economic growth down to minimum, led to a sharp fall of investment and capital runaway, decrease in business profitability. According to Center of macroeconomic analysis and forecast, in 2013–2015 profitability of sale decreased, and credit debts of population grew over the period of 2008–2014,

multiplication effect of state megaprojects fell, 1/4 of investments does not compensate, and their total profitability is lower than credit price and income of placing bank deposits. The basic income is formed not of production, but natural, monopolistic, political-administrative rent that is received by raw material companies and monopolistic intermediaries.

Russia requires a new model of growth (3) that will aimed to establish deficitless budget and decrease in inflation, but first of all – acceleration of economic growth due to increase in volume of strategic investment into modernization of economy. According to S. Glaziev and other economists (2), development of real anti-crisis strategy is impossible within the existing liberal-monetary paradigm. The problem is not solved by free market flow of capitals, especially as Russian banks do not possess sufficient capacity and are speculative, they depend on financial non-residents and are unavailable for the majority of Russian enterprises. Internal market, exposed to pressure of foreign competition, is unable to solve problems of modernizing economy and developing its high-technological sectors without support of purposeful state policy. Commercial banks are unable to grow their capital up the level that will be adequate to needs of real sector.

The main reason of economic growth stagnation is decrease in pace of labour efficiency growth and loss of cheap price for resources that compensated low productivity.

Russia can improve production efficiency dramatically via creating new and liquidating old outdated working places, especially in the area of communal urban and village infrastructure, roads, power industry, machinery construction, agrarian-industrial complex, increase in GPD investment share. These measures will compensate gap between volume of savings and production investment. It requires real social-governmental private partnership that will attract local, not only state and foreign investment, new tools of preferential long-term crediting, development of subfederal and corporate obligation loans, creation of profitable market of dwelling-communal service at the foundation of new technologies and real competition.

According to the presented material, economy of state and municipal sector can expect the following changes in the next several years: new industrialization becomes the main factor of modern economic development in terms

of geographical shifts in global economy and change in structure of world economy (5). New industrialization has its principal differences in objectives, methods, and behavior. Its essence lies in transition from mechanized to robotized production.

New industrialization creates innovative strategy for global economy and management system (6). For Western countries new industrialization implies return of production, outsourced to countries with cheap labour, to scientific centers with new robotized base that will provide for a dramatic decrease in laboriousness. At the same time, according to Yale University (USA) (7), firms will transit from output of mass product to limited production and continuous assortment refreshment.

For Russia new industrialization implies creating of new 20–25 million places of work for qualified and well-stimulated labour. Light industry requires fundamental change of material and technical base, introduction into global chains of supply (4). Analysis of structural shifts, trends, and sources of investment (1) shows us perspectives of transforming machine building, military-industrial complex, and sector of service.

A number of publication uses the term “new economy” only in relation to computer building and instrument making, radio electronics, precise machine building, nuclear power industry, accurate chemistry, and other sectors, for which science intake exceeds 5–7%. At the same time, “new” economy is often studied in conflict with traditional industries: almost all savings, made with oil, mining, and other “old” industries are supposed to be withdrawn and invested into the “new economy”. There is no reason for such contradiction. Oil, light, construction, fish industry can and should become science intensive branches of economy, use modern technologies and methods of organizing production. None of informational products can replace traditional consumer goods.

A special part in transforming state and municipal sector is devoted to transition towards informational economy, economy of knowledge.

Information is transition of biological or material carriers from one subject to another along connection lines. This definition removes or limits the uncertainty of economic activity and making economic decisions at micro and macrolevel. Information becomes the basic productive resource.

The list of major characteristics of informational economy includes:

- transformation of new knowledge, information, methods of their efficient implementation into the main form of social wealth;
- transition to complex-automatized and computer-assisted production with minimum of environmental pollution;

- growth in human capital value, thorough development of abilities and initiative of workers, their attitude to work;

- continuous refreshment of product assortment, technology, organization of output, labour, and management;

- transformation of service sector and science-intensive branches of production into the sector of employment and GDP;

- globalization and internationalization of production, creating world market of consumer goods, capital, information, and labour technology;

- creation of information banks in all branches of knowledge and types of employment, accessible directly from a workplace or dwelling.

The necessity of state regulation in the area of informational technology is defined by uneven access to modern informational-communicative technologies and products in different countries and world regions, monopolizing world market of informational products by the leading transnational corporations that state their terms and standards to consumers, asymmetric nature of information, danger of world terrorism and cybercrime.

State and municipal sector play a significant part in transition towards new, sixth technological cycle that is expected in 2020–2030.

The sixth setup is based upon transition towards nano- and biotechnologies, new physical-chemical and informational-cognitive (influencing thinking and behavior of people) concepts that transform not only the form, but also internal atomic-molecular and gene-cellular structure of labour object, the whole system of production. Social-innovative economy implies transition to small and moderate production that does not require transporting and processing great mass of natural raw materials, individual work at a completely new scientific-informational foundation of the new model of production evolution (that creates robotized computer assistants, new genotype of communication between material objects, firms, and people. (The Economist, 26.04.2014).

New forms of managing knowledge and intellectual property require transition from cybernetic (management according to oscillations from the existing goals) to synergetic management at the foundation of normative regulation of non-linear and unequal processes. System of knowledge is created at enterprises and it will include:

- Defining criterions of significance and value for a certain type of knowledge.

- Organization of search, storage, analysis, and presentation of data according to the corresponding requests in real time with digital databases.

- Classification of data according to types of product (order), market sectors, and business units.



– Development of concepts on structural elements and job descriptions that will allow to set clear communication and addressness of data transmission, exclude its duplication.

– Creation of data protection system, regulation of access and protection of commercial secret, including the process of resignation for employees who possess it.

– Organization of digital data exchange between services of marketing, innovation, production, service, and setup of internal informational network.

Cloud calculations allow each company to create digital area of selecting the best suppliers and consumers throughout the world, searching and mastering innovation, organizing logistic that will allow them to exclude warehouses and overstocking.

Modern economy is characterized by revolution in business organization, related to clustering, development of global supply chains, creation of value, transition from vertical to horizontal cooperation through establishing strategic alliances, modern innovation-investment pro-

jects, franchising, trust (not possessing any property) managing companies.

#### References

1. Berezinskaya O., Vedev A. Investment process in Russian economy: potential and directions of activation // Questions of economy. – 2014. – № 4.
2. Glaziev S., Fetisov G. New course: strategy of breakthrough // Economic strategies. – 2014. – № 2.
3. Mau V. In wait for a new model of growth // Questions of economy. – 2014. – № 2.
4. Radayev V. Can Russian light industry be saved? // Questions of economy. – 2014. – № 4.
5. Tatrkin A., Amureyeva E., Ratner A. Imperatives of modern economic development: world trends and Russian reality // Questions of economy. – 2014. – № 5.
6. Cault F. Innovation strategies by a global economy // Development implementation, measurement and management Cheltenham (U. K.). – 2011.
7. Marsh P. The new industrial revolution: consumers, globalization and the end of mass production Hew Haven (Conn.). – Yale University, 2012. – P. 311.

---

The work is submitted to the International Scientific Conference «Economic mechanism of innovative development», France (Paris), March, 19–26, 2016, came to the editorial office on 26.02.2016.

*Materials of Conferences*

**EFFICIENCY OF MODERN  
DIDACTIC PRINCIPLES  
OF PERSONALITY-ORIENTED LEARNING  
TECHNOLOGIES IN HIGHER MEDICAL  
EDUCATION IN UKRAINE**

Iermolenko T.I., Karnaukh E.V.  
*Kharkiv National Medical University,  
Kharkiv, e-mail: ella69k@mail.ru*

The modern European system of higher education in Ukraine seeks to steadily improve the forms and methods of training, the maximum zoom it up to modern standards organization, to give every student a quality and effective education.

The priorities of the state policy in higher education is a personal focus, continuous improvement of education quality, update its content and form, the introduction of innovative educational technologies, integration of national education to European and world education.

Innovative teaching didactic methods experimentally confirmed by the example of the discipline "Pharmacology" in Kharkiv National Medical University.

Teaching by Pharmacology as one of the main theoretical subjects preclinical and clinical training of future doctors are constantly improving.

In terms of educational innovation and reform the education system, improving quality is an important social problem, which is caused by the processes of globalization and the need for creating conditions for individual development.

In our country there are changes in the educational process aimed at improving the quality of training, including the use of personality-oriented learning technologies.

Applying by modern student-centric model organization of quality higher medical education, we have implemented educational technology of interactive training module based on REAL- methods by N. Maslova and with forming by individual student academic portfolio.

Experimental study of the application of these personality-oriented technology training was conducted among students of 3rd year medical faculty. The results of this pedagogical experiment proved that in terms of student-centric learning model gradually reveal all personal information learning opportunities and of student's intellectual potential.

Each student analyzes the information, its reproduction, storage, systematization and generalization and also aware of their personal responsibility for the decision and the work done.

This gives the opportunity to update and deepen knowledge of the learning discipline, improve internal and external student's motivation, confirm the high level of knowledge and get good results that meet modern European standards of higher medical education.

This reflects the psychological and pedagogical direction of a high school teacher for the organization of all parts of students at workshops.

The work is submitted to the International Scientific Conference «Development of Scientific Potential of Higher Education», UAE (Dubai), March, 4–10, 2016, came to the editorial office on 31.01.2016.

**ACTIVIZATION OF STUDENTS'  
COGNITIVE ACTIVITY IN IT  
LESSONS REFERENCES**

Kaldarova B.S., Daulenbaeva T.P.

*M. Auezov South-Kazakhstan State University,  
Turkestan, e-mail: tan-1007@mail.ru*

The article deals with the activization of students' cognitive activity in IT lessons. It is important to determine an internal and directly related motive to the content of this activity. Revitalization of the students' cognitive activity in IT lessons.

**Introduction.** Active learning methods are allowed to be used in all levels of assimilating knowledge from reproduced to transforming activity through the main goal – creative-search activity.

Creative-search activity is more effective if it is preceded by reproduced and transforming activity in which students learn the techniques of teaching.

Information technologies let teachers and students to use various sources of information such as text, sound, images and video in the creative activity in the classroom.

In modern conditions the main task in education is not only getting students of certain knowledge and skills, but also to develop the students self work skills. So, the role of a teacher is very important in disclosure of the potential in new computer technologies. The practice has shown that students who has actively skills in using computer shows a higher level of orientation in the flow of information which allocate important sources and systematize and generalize.

Factors which stirring up the students cognitive activity in using the computer at the lesson are:

1. Aids (not passive and active) ie ability to control the demonstration process.
  2. The keypad operation, which increases the correlation of motor reactions and processes of perception.
  3. Opportunities of self-control.
  4. Opportunities to visualize the processes that previously could not be observed.
  5. Opportunities of individualization in training.
  6. Modeling.
  7. Solving problems with the help of the software.
- Activate students cognitive activity by using the following methods:

- development of the project is: after studying the topic, students prepare appropriate presentation. This work can take a long time to allow students

to be successfully implement of the solution search and research tasks;

- internet resources, which expand the content of information obtained for self work that allows to establish various projects are not only illustrations, maps, charts, photos also create searching and organizes various reference;

- role plays;
- virtual excursions;
- interactive programs, tests, electronic textbooks and graphic presentations.

One of the tools is the program Power Point. In this program, teachers and students create presentations, allowing to illustrate the material in training;

- videoranimation films;
- students' creative work. Drafting and crossword puzzles, rebuses in IT classes, creating case studies, participating in contests.

The solution of the problem

The creative nature of the activity is determined in the process of continuous monitoring of the execution of tasks by each student or by the students themselves in the following items:

- level of the student's motivation;
- original methods and clearance;
- imagination and originality;
- use of interdisciplinary connections;
- ability to perform self-analysis of its activities and the identification of the applied methods and evaluation of results.

In a complex of pedagogical conditions and means of activation of students' cognitive activity in the content of the studied material is defining. Exactly, the content of the subject is one of the leading motives of students' cognitive interest. Selection of the content of teaching material should be made taking in to account of the students interests. In selecting the content of the material is necessary to consider its prospects, practical and personal significance for students urgency.

It is important to use active methods of teaching adequate to the content of the material to the solution of a problem of activation of students cognitive activity. In this case it is possible to teach students to apply their knowledge in new and unusual situations, i.e. to develop elements of creative thinking.

Success in solving problems of activating the learning of students' are the optimal combination of innovative and traditional teaching methods. The success in the problem solution of an activation of cognitive activity of pupils' consists of an optimum combination of innovative and traditional methods of training

New information technologies influence all system components of teaching: the purposes, the contents, methods and organizational forms of education, tutorials that allows to solve complex and actual challenges of pedagogics, namely: development of intellectual, creative potential, analytical thinking and independence of the person.

The most important point here is the result of performed actions. Hardly, a weak or average student will draw an activity whose purpose or result – teaching. The doctrine now is “not in vogue”. In addition, the majority of students are often not

even aware of the role of knowledge obtained in school. Therefore, the result of any practical work must necessarily have personal significance for the student, that is, motive. One of these motives may be binary lessons. The student does the work and informatics, and to another, or other subjects, spends much less time to prepare, and received several estimates. In this case, there is a motive for knowledge, the desire to develop further action. Another means for solving this problem may be the method of projects. About him in recent years, many said and written. Accent just focus on the fact that the project activity, depending on the ongoing educational tasks can take all sorts of forms: it can be a great project for the whole academic year or more (it can be cross-cutting, that is not to interrupt the classical lessons), but can – draft on one or several lessons (mini-project). Of course, not every activity possible and appropriate to transform the project.

Here are some more examples of activation of informative activity of students using the following methods:

- special way to formulate the objectives of the student, denoting his personal interest (even if it will even be interest in a mark, or label the practice as a stage in the more important tasks that simply must be overcome;

- add into practice game, competitive moment, then she will gain at least temporary significance;

- create an unusual atmosphere during operation, making an unusual lesson.

It is crucial to the practical activities carried developing character, so there must be a minimum of instructions, a maximum of independent research, search, analytical activities. Let the students will find the right algorithm, and maybe it was his decision will be the best and original. Finally, to enhance the cognitive activity in the study of complex or “dull” of the material, how often programming, recommend from the beginning to demonstrate the amazing results that can provide one or the other learning material.

#### References

1. Apatova N.V. Information Technologies in Scooling. – M.: Prosveshenie-ACT, 1994. – P. 362.
2. Bulgakova N.N. Activation of younger pupil's cognitive activity in IT lessons. “Educational technologies”. – SPb.: NOVA, 2004. – 482 p.
3. Dubovitsky T.D. The method of diagnostics of an orientation of educational motivation. – <http://psyedu.ru/view.php?id=84>.
4. Smolina L.V. Application of modern methodology of productive training in a school course of informatics and ICT // Sb. works of N-pr.konferentsii of OGPU. – March, 2006.
5. Khutorsky A.V. The method of the personal focused training. – M.: Vladoss-press, 2005. – P. 55.
6. Khutorsky A.V. Didactic heuristics. Theory and technology of creative training. – M., 2003.
7. <http://www.eidos.ru/journal/2002/0423.htm>.
8. Khutorsky A.V. Key competence and educational standards // Internet magazine “Eydes”. – 2002. – <http://www.eidos.ru/journal/2002/0423.htm>.

The work is submitted to the International Scientific Conference «Modern problems of science and education, RUSSIA», Russian, (Moscow, Russian Academy of Sciences (RAS)), February, 25–27, 2016, came to the editorial office on 19.11.2015.

*Materials of Conferences*

**YOUTH PRO-NATALIST POLICIES:  
SOCIAL AND ECONOMIC ASPECTS  
(CASE STUDY SOME REGIONS OF RUSSIA,  
FRANCE AND GERMANY)**

Gokova O.V.

*Omsk State University n.a. F.M. Dostoevsky,  
Omsk, e-mail: capri484@yandex.ru*

A modern young person appreciates most of all his or her personal freedom and independence and puts his or her interests superior than those ones of other people and the society. In such picture of the world children, even if they are welcome, are associated with extra expenses and additional troubles and are considered as factors limiting an adult. The given article analyzes the results of three empirical researches, conducted in Russia, Germany and France, points out corresponding values of modern young people, the character of their social behavior in the demographic aspect and factors influencing such behavior. The experience of pro-natalist policies in regions of France and Germany, the opinions of experts, received in experts' interviews, allowed to formulate and work out the measures to affect the young families in the framework of pro-natalist policies, i.e. policies serving the increase of a birth rate, marriages and natural natality.

Modern globalization influences the transformation of the reproduction framework and its consequences force modern society to change the priorities of the demographic policies. Surprisingly, but nowadays the lowest level of a birthrate is registered in the developed countries. And vice versa, there is the highest level of this index in the developing countries. Hence, we can observe an inverse relationship between the welfare of the population and the index of a birthrate, so it is obvious that reproduction priorities depend not only upon material incentives, but upon different factors, starting from social, ethnic, religious up to educational, moral-psychological ones.

Recently, in spite of the improvement of the demographic situation in Russia, our state is still in the demographic crisis, which in accordance with the opinions of some researches will increase, having negative quality and quantity consequences for the development of the population. Modern demographic policies are characterized only by the economic measures and do not remove the reason of the demographic crisis, so it is partial and temporary, as the crisis is conditioned not only by the economic factors. Nowadays the measures which are taken in RF to stimulate the birthrate are realized by authorities without proper understanding of the factors, influencing the reproduction activity of the population, without regional differentiation of these measures and their connection with the socio-economic

policies in regions, realizing an average approach to the stimulation of a birthrate for different groups of the population. It requires the systematization and taking into account all the conditions for the provision of a proper level of the life of the people and a separation of a certain demographic branch – pro-natalist policies, the formation of which should start at the regional level for the solution of the demographic crisis and the following achievement of the nationwide results.

Russia is not the only country where we can observe population decline tendencies. Almost all the developed countries are at the stage of «the second demographic transition» which is characterized by a high level of the welfare, women's involvement in the industry, an increase of their social role, an increase value of the higher education and as the consequence a decrease of the level of a birthrate, transformation of the social approach to the family behavior.

If we take this fact into account, there is a necessity to handle a comparative analysis of the factors influencing the changes the reproduction behavior of the population in different countries, people's attitude to marriages, to a birth out of the wedlock and the measurers of the demographic policies. Russia, Germany and France were chosen as territorial objects. Russia and Germany have common tendencies of the demographic development, whereas France is a state which has been realizing active pro-natalist policies since the end of the XIX century.

In the research we suggest to concentrate the attention on the exploration of the views of the youth, as the one is the main resource for the reproduction of the population – natural, migration and social and has the main load connected with the reproductive behavior, particularly, the formation of families, childbirth and the raising of the children.

The novelty of the project is the author's approach to the creation of the mechanisms of the realization of the youth policy taking into account the experience of the developed countries (Germany and France) and different factors influencing the reproductive behavior of the youth on the example of one of the territorial object of RF (Omsk region).

The expected results of the research will be the identification and systematization of the factors which influence the reproductive behavior of the youth of Omsk region, similar regions of France and Germany, the attitude of the youth to marriage, family, the childbirth out of the wedlock, the use of contraception, axiological values of the youth in different countries, the state support of families with children. All these will allow to work out the author's model of the pro-natalist policies and its unification which goals to be suggested to the regions with the conditions similar to Omsk region's ones.

As a result of conducted researches, the experience of Russia, Germany and France (in carrying out pro-natalist policies) was analyzed and the following connection was found out: reproduction behavior of the youth of the mentioned countries depends on the quality of the provided state measures and creation of a positive image of a strong and united family. Also the peculiarities of pro-natalist policies in Germany and France were distinguished.

Today's unified nation-state of Germany was, prior to 1990, composed of a conservative welfare state in the West, and a socialist system in the East. The two states followed two different policy paths during the division of Germany from 1949 to 1989 [1, p. 559]. In the East, childbirth and the employment of both parents were supported, and the dual-earner family was the dominant family model. In West Germany, politicians followed the male breadwinner model, which supported marriage and the traditional division of labour between husband and wife. However, in order to avoid analogies with Nazi Germany, West German politicians tended to reject pro-natalist policies. Based on the principle of «sustainable family policy», which was first introduced in 2002, the German government has been seeking to increase fertility and reduce child poverty by mitigating work-family conflicts.

Currently, Germany has a mixed system of child benefits and tax allowances which redistributes resources from childless people to families, and from higher-income families to low-income families. Child benefits are virtually universal, and are paid as monthly lump-sum payments per child, with the amounts varying depending on the number of children in the family (2014: 184 euros for the first and second child, 190 euros for the third child, and 215 euros for the fourth and each additional child). The benefit is generally paid until the child is 18 years old, or 25 years old if the child is in education. However, from age 18 onwards, the benefit is means-tested based on the income of the child. Whether parents are entitled to tax allowances beyond the child benefit payments is determined by the tax authorities when the parents file their tax return. Parents with annual incomes above approximately 63000 euros (or singles with annual incomes above 33500 euros) are eligible for additional tax allowances [2].

As for France, family policy has a long history there, and fertility has traditionally been a political concern. Compared to other OECD countries, public investment in families with children is relatively high. In 2009, when France spent about 3,8% of GDP on family benefits, cash payments, and services and tax breaks for families, the country had the highest investment level in the OECD, which had an average spending level of 2,9% [5].

The development of childcare-related policies in France can be broken down into four main periods:

1. Before the 1970s: Policies encouraged the male breadwinner model, in which men worked and women stayed home. These measures included tax cuts for

families and (from 1946 to 1972) a single wage allowance for households with a single wage earner.

2. The 1970s and the 1980s: Policies became progressively more supportive of mothers' labour market participation, with the progressive abolition of the single wage allowance in 1972, the introduction of a childcare allowance for households with a working mother, and the development of public childcare services in the 1980s. However, in 1985 a parental education allowance for women with three or more children who left employment to care for their children was introduced. This allowance aimed exclusively at large families was unique in Europe [6].

3. The 1990s: Policies promoted the diversification of childcare with the development of public subsidies for both collective and individual home-based services. Parents employing a registered child-minder at home or at the child-minder's home received an allowance covering the payment of social contributions for their employee; the childcare costs could also be deducted from taxable income. However, the parental education allowance was extended to mothers with two children in 1994, and to mothers with one child in 2004 (but for six months only). Thus, there was a dualism in childcare policies which had unequal effects across households.

4. From the mid-2000s until today: Policies have placed more emphasis on the diverse needs of families. Recent policy initiatives have included the following:

- The development of services for working parents with non-standard hours was set as a main supply-side objective;

- Specific centres with medical and social assistance have been developed since 1976, and services for families with children with disabilities or severe illness have been improved;

- Meeting the needs of low-income families and children with disadvantaged backgrounds (especially children of poor families and of migrant families) has been re-affirmed as a policy priority. In 2006, a law was passed that increased the availability of childcare services for families receiving social assistance by requiring municipalities to provide childcare places to the children of these families who are not already attending school. A minimum of one in 20 childcare places must be reserved for these children. These goals were reaffirmed in a 2009 law on social assistance, which also gave priority in access to childcare to children with parents who are currently undergoing a process of social inclusion (regardless of whether they are receiving benefits). Finally, the 2012 conference on poverty set the objective of delivering more childcare places for children from poor families, who are expected to represent at least 10% of all children in collective centres [4];

- There are many different kinds of childcare providers in France offering a wide range of services, from individual (home-based) to collective (centre-based) care. The governance of childcare availability and quality involves various actors, from

municipalities to the central government. Reforms of the governance structure were carried out to encourage the diversification of services (i.e., to encourage the development of services for parents with non-standard working hours, to facilitate access for poor and migrant families, and to provide services for children with disabilities or severe illness). Recently, the supply of childcare services has been expanded through an increase in the number of child-minders [3].

The key challenges for childcare policy-makers are to ensure that the recent expansion of childcare services (including of out-of-school care) takes into account possible future reforms of parental leave, and to ensure that the supply of services for parents with non-standard working patterns continues to increase. Reducing inequalities in the costs to families for the use of public centre-based services and home-based child-minders is another option under discussion. Addressing children with specific needs would also call for the adaptation of child-minder training schemes.

Thus, taking into account the empirical data of the researches and the experience of pro-natalist policies in Germany and France, we worked out a set of measures of pro-natalist policies at the regional level.

1. In our opinion, one of the most important measures of the mentioned above policies should be the change of the provision of the maternity leave. As our research shows the most important factors, influencing the delay or refusal a child birth, is the fact that most women (including Russian ones) do not want to leave their social and professional life for a long time because of a birth and rising of a child. Having a maternity leave for two-three years often makes a woman uncompetitive on the job market, she loses professional skills. Many Russian women are completely involved in the process of upbringing a child and do not participate in the social life. The development of a free market and the increase of possibilities of women's employment can become a more important factor influencing the increase of a birth rate, than special family-demographic measures in this aspect. Policies which support the access to jobs for women and protects the saving a job and provides adequate income in most of the cases is a good condition for making up a decision to have a child (or one more child). The goal of such policies is integration of mothers in the professional sphere. Long maternity leaves and gender-segregation policies show that combination of work with a motherhood, the return to the job market after a maternity leave and the preservation of the previous standard of life can become rather difficult. It leads to the decrease of a birth rate.

Our suggestions are to provide several variants of a system of maternity leaves and benefits in accordance with the wishes of parents:

a) maternity leave of a 4 months' length with saving a job and 100% of wages. After that a woman can return to work and use the service of a certified baby-sitter who looks after children either at her own place or comes to parents' house;

b) maternity leave divided between both parents: part of a leave is taken by mother (3,5 months),

then she returns to work, the second part is taken by a father (up to 3,5 months) with saving jobs and 100% of wages. After a maternity leave parents can return to work and use a service of a baby-sitter (as in the first variant) or take a child to a kindergarten or prolong a partially paid maternity leave with saving a job which can last up to 3 years.

2. Existing model of pre-school education in Russia is provided mainly for children from 3 to 7 years, so, there should be a versatile system of care of the children who did not reach 3 years and system of women's work support.

3. Another measure of the pro-natalist policies can be the construction of a culture of a work-life balance.

4. A construction of a «supporting environment» which includes a lot of devices and daily practices making life easier.

5. According to the results of sociological interviews the problem of a dwelling is the most important one for young families. In this direction it is expedient to develop a system of mortgage credit lending for young families, including low lending rate which can depend on the number of children (the more children the lower lending rate).

Thus, a realization of a systematic combination of diverse variants of socio-economic policies towards families with children (including direct help, tax benefits, construction of an infrastructure) is an important condition for youth pro-natalist policies effectiveness. Modern demographic situation in Russia and the need to sustain the achieved results demands to work out new solutions and the use of best international practice (including the experience of France and Germany).

#### References

1. Dorbritz J. Germany: Family diversity with low actual and desired fertility // *Demographic Research*. – 2008. – № 19. – P. 557–598. – URL: <http://www.demographic-research.org/volumes/vol19/17/19-17.pdf>.
2. Germany: A modern family policy for more partnership when it comes to creating a work-family balance and economically stable families // *European Union: European Platform for Investing in Children*. – URL: [http://europa.eu/epic/countries/germany/index\\_en.htm](http://europa.eu/epic/countries/germany/index_en.htm).
3. Lépinard E., Lieber M. The Policy on Gender Equality in France // *European Parliament*. – URL: [http://www.europarl.europa.eu/RegData/etudes/IDAN/2015/510024/IPOL\\_IDA\(2015\)510024\\_EN.pdf](http://www.europarl.europa.eu/RegData/etudes/IDAN/2015/510024/IPOL_IDA(2015)510024_EN.pdf).
4. Thévenon O. Does Fertility Respond to Work and Family-life Reconciliation Policies in France? // *Research Gate*. – URL: [https://www.researchgate.net/publication/46479023\\_Does\\_fertility\\_respond\\_to\\_work\\_and\\_family\\_reconciliation\\_policies\\_in\\_France](https://www.researchgate.net/publication/46479023_Does_fertility_respond_to_work_and_family_reconciliation_policies_in_France).
5. Thévenon O. Family Policies: France // *PERFAR: Population Europe Resource Finder & Archive*. – URL: <http://www.perfar.eu/policy/family-children/france>.
6. Vanovermeir S. L'accueil des jeunes enfants: axe majeur de la politique familiale française depuis les années 1970 // *Ministère des Affaires sociales, de la Santé et des Droits des femmes*. – URL: <http://drees.social-sante.gouv.fr/IMG/pdf/article31.pdf>.

The work is submitted to the International Scientific Conference «Economic mechanism of innovative development», France (Paris), March, 19–26, 2016, came to the editorial office on 04.03.2016.

*Short Reports***RUSSIA AND THE ROME STATUTE OF THE INTERNATIONAL CRIMINAL COURT: RATIFICATION PROBLEMS**

Gracheva R.O.

*Kursk state medical university, Kursk,  
e-mail: kopcevarada@mail.ru*

The short message opened the question about the ratification by Russian Federation the Statute of the International criminal court. There are numerous and formidable political and legal obstacles which don't allow the Russian Federation to ratify the Statute of the ICC soon.

According to the order of the President of the Russian Federation of September 8, 2000 № 394-RP Russia signed the Statute of the ICC, having expressed thereby the approval of the general idea of creation of this body, its purposes and tasks. However so far this document is officially not published and not ratified. We will consider the reasons of that the Russian Federation still didn't ratify the Rome Statute of the International criminal court.

The contradictions existing between separate provisions of the document and a number of articles of the Constitution of the Russian Federation belong to constitutional and legal aspects. For an adequate assessment of prospects of implementation of provisions of the Statute of the ICC defining the basic principles of activity of the International criminal court it is necessary to consider the limits of implementation of norms of international law set by the Constitution of the Russian Federation [3].

Meanwhile a number of provisions of the Statute of the ICC contradict standards of the Constitution of the Russian Federation, including:

1) transfer of persons to court that contradicts the Constitution of the Russian Federation guaranteeing that "the citizen of the Russian Federation can't be sent out of borders of the Russian Federation or is given out to other state";

2) the inadmissibility of the link to official capacity assuming application of the Statute of the ICC to heads of state and government, members of the government and parliament that contradicts the Constitution of the Russian Federation, guaranteeing immunity of the President, members of the Federation Council and the State Duma;

3) the exceptions of the principle of "ne bis in idem" (is impossible to judge twice for the same) contradicting article of the Constitution of the Russian Federation which isn't providing any exceptions of this principle.

Now in the Russian legislation there are no the norms providing transfer of citizens of the country of any international organization or to other state.

This constitutional norm reflects the important principle of citizenship of the Russian Federation which consists that the Russian Federation guarantees to the citizens of the right and freedom, assigned in Constitutions, and also protection and protection to its limits [1].

Further about international legal aspects. As it was noted above, a number of provisions of the Statute of the ICC contradict norms of international law, including norms on immunity of the highest officials from foreign criminal jurisdiction. The question of privileges and immunities in the international criminal law is one of the most actual and sharp, and attempts of its decision unilaterally and by force lead sometimes to serious complications in the international relations.

Besides, the Statute of the ICC contradicts the conventional principles and norms of international law on human rights in the sphere of criminal legal proceedings. So, according to point 7 of article 14 of the International covenant "About the civil and political rights" 1966, "nobody has to be again judged or punished for a crime for which it was already finally condemned or justified according to the law and the criminal procedure right of each country". The same principle is enshrined in article 4 of the Protocol № 7 of the Convention "About Protection of Human Rights and Fundamental Freedoms" of 1950: "Nobody has to be repeatedly judged or punished in a criminal order within jurisdiction of the same state for a crime for which it was already justified or condemned according to the law and criminal procedure norms of this state" [4].

We will specify criminal and legal and criminological aspects. In comparison with the numerous constitutional and legal and international legal problems arising in connection with discussion of a question of ratification of the Statute of the ICC in the sphere of criminal law practically there are no obstacles for its ratification. It is explained by features of a subject of regulation of this act: unlike the majority of the international treaties existing in the sphere of fight against crime, the Statute of the ICC doesn't assign a direct duty to establish criminal liability for the crimes specified in it to the states.

In this regard it must be kept in mind that the norms of the international criminal law regulating responsibility for the heaviest acts are already incorporated in the Russian criminal legislation.

Besides, it is necessary to consider provisions of the principle of legality according to which crime of act, and also it's punish ability and other criminal and legal consequences are defined only by the Code. Thus, criminal prosecution on the basis of other legal act, in particular the Statute

of the ICC, in Russia is excluded. At the same time, the Criminal code is based on the Constitution of the Russian Federation and the conventional principles and norms of international law that gives the chance to consider the Statute of the ICC as a source for improvement of standards of the criminal code of Russian Federation by inclusion of a number of new structures of crimes in it. However it doesn't mean recognition of jurisdiction of the ICC concerning the crimes committed in the territory of Russia or beyond its limits, but against its interests.

The criminological factors operating in the sphere of the international crimes are connected with character and scales of these acts. These factors are the bases of establishment of criminal liability for these or those socially dangerous acts. Statistical data testify that in 2001–2004 in the Russian Federation no more than 1–2 crimes against the world and safety of mankind in a year were registered. This fact testifies to inexpediency of participation of the ICC in the course of criminal prosecution of the persons guilty of commission of similar crimes. The solution of this task is quite of forces to national judicial authorities.

In the conclusion we will consider financial aspect. At a solution of the problem of ratification of

the Statute of the ICC along with legal and political affairs it is necessary to consider also financial aspect of this problem. According to the Statute of the ICC, financing of activity of court is carried out, mainly, at the expense of contributions of the State Parties which size is established by the decision of Assembly of these states.

Now the size of a contribution makes the sum equal to 2,5–3% of the national budget of the country. That exceeds expenses on all judicial system of the country by 2–3 times. Our country will go to such expenses as they aren't justified [1].

Thus, there are numerous and formidable political and legal obstacles which don't allow our country to ratify the Statute of the ICC soon.

#### References

1. Bogush G.I., Trikoz E.N. International criminal court: problems, discussions. – M., 2008. – P. 45–52.
2. URL: <https://geneva.usmission.gov/2013/09/30/u-s-announces-additional-humanitarian-assistance-in-response-to-the-darfur-and-central-african-republic-crises/> (дата обращения 12.02.16).
3. URL: [http://www.un.org/ru/law/icc/rome\\_statute\(r\).pdf](http://www.un.org/ru/law/icc/rome_statute(r).pdf) (дата обращения 12.02.16).
4. URL: [https://www.icc-cpi.int/iccdocs/asp\\_docs/ASP9/OR/RC-11-RUS.pdf](https://www.icc-cpi.int/iccdocs/asp_docs/ASP9/OR/RC-11-RUS.pdf) (дата обращения 12.02.16).