

Short Reports

THE WIDELY – REGULABLE THYRISTOR CONVERTERS CALCULATION AND INCREASING POWER FACTOR

Magazinnik L.T.

The Ulyanovsk State Technical University, Ulyanovsk,
e-mail: tai@ulstu.ru

About a third of the electric power, having produced in the country, is being converted into BC or the other frequency currents. So, in the large power plants (e.g. above 500 kWt), mainly, the thyristor converters (VT) are being used for all these purposes. Their efficiency is being reached 97%, however, the vulnerable spot is the low power factor (K_m) at the wide regulation of the output co-ordinates (e.g. current, voltage). For example, the weight average K_m

of the reversing rolling mills electric drives is not exceeded 0,4; and because of the change high rate of its reactive power compensation should be conducted in such facilities, either by the compensators commensurable rapid performance, or by the forced switching in the converters themselves [1, 2, 3].

When there is the natural commutation, the K_m increase is achieved, due to the control laws complication by the converters. So, from the thyristor bridges connected in series 2–3 has been found its practical application (e.g. for the reversible VT ones) (Figure, B). These bridges are usually powered by two identical matching transformer of the secondary matching 1, and the loose connections of the above – mentioned bridges are practically connected in the anti – parallel to the load 4.

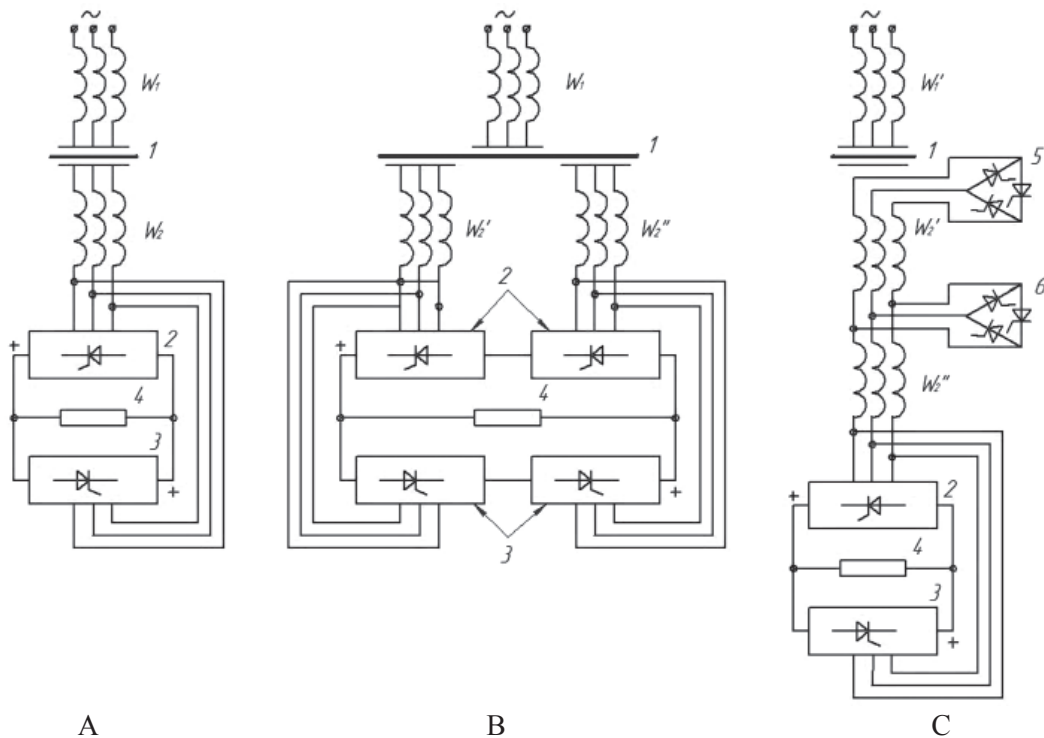

A – symmetric control; B – serial; alternate; C – alternate with the voltages summation at the alternating current (AC) side; W_1 and W_2 – the primary and secondary windings of the matching transformers

We would note, that, as in sequence, or in the other well – known control laws, in the established practice:

$$C_p = \cos \alpha \approx Ed/Ed_0; \quad (1)$$

$$\cos \varphi_1 = \cos (\alpha + \gamma/2), \quad (2)$$

where α – is the steering angle; γ – is the angle switching; Ed/Ed_0 – is the degree of regulation (C_p); φ_1 – is the shift angle of the first harmony power, relatively to the voltage.

The Equation (1) is ignored the fact, that practically any VT is usually the element of the closed system of the automatic control system (ACS), having maintained the output coordinates set constancy. For example, $C_p = \text{const}$. the load variations from the zero, to, at least, the nominal, at the voltage fluctuations mains supply (e.g. + 5...–10) %, and for the reversing VT (Figure) the energy inverting mode should also be ensured to the grid at the maximum allowable current VT and the load, that it is limited

α_{\max} . In connection with the foregoing, the following real $\cos \varphi_1$, and Km are defined, having taken into consideration of the above – mentioned requirements, referred to VT and to the load, at the both control laws (e.g. as the symmetric one, well as the alternate one), and it also is proposed the quite new scheme of the alternate control, which is more economical, and simple, in comparison with the already known one.

From the above – listed requirements, the most critical is appeared to be the conservation $Cp = \text{const}$ at the acceptable power supply voltage variation, which it is quite obviously, that the equation (1) for the closed ACS should be replaced by:

$$Cp = Ud/Ud_0, \quad (3)$$

where $Ud \leq 0,9Ud_0$, as the necessary voltage supply is made up about 10%.

In the general case:

$$\overline{\cos \varphi_1} = \cos(\arctg \overline{Q}/n\overline{P}), \quad (4)$$

where n – is the number of the series – connected VT, \overline{Q} and \overline{P} – are the mathematical expectations of the reactive and active powers of one VT.

The calculations by the expressions (e.g. 3 and 4) are given for the symmetric control ($n = 1$), $\overline{\cos \varphi_1} = 0,45 (0,5)$, for the alternate one (when $n = 2$) – $0,715 (0,755)$. As it is well – known, the distortion coefficient of the three – phased bridge circuit is made up $0,955$ (e.g. without switching). Then, $Km = 0,43 (0,47)$ in the Scheme 1a, and it is equal to $0,68 (0,72)$ in the Scheme 1b. Thus, for the clarity, the $\overline{\cos \varphi_1}$ and Km are given, in the parentheses, at the calculation by the formula (1), having given the significant overestimation the $\overline{\cos \varphi_1}$ and Km .

We note, that the derived data are also somewhat overstated on the basis (3, 4): the reduction $\overline{\cos \varphi_1}$ is quite unspecified in the dynamic modes [4], as there is no correlation with the load, and also the stochastic oscillations of the current and voltage, having required for the theory attraction calculations of the stochastic processes, are not taken into account, that is quite beyond the scope of this paper.

Below (Figure, C), the new converter circuit is considered, which is quite identical by the energetic indicators for the same “ n ” to the “classical” alternate control (Figure, B). So, the scheme is being operated the following way. In the idle status, the transducer switch is closed, that is, all its three thyristors are being switched on, and the steering angle is $\alpha \geq \pi/2$ in the both bridges 2 and 3. Consequently, the W_2'' winding is being connected into “the star” one, as the similar switching in the Figure, b. At the angle α changing, for example, in the converter 2 from $\pi/2$ to the zero, the voltage is appeared at the load 4, which is equal to $0,5$ time of the rated voltage. So, this step is quite the similar to the first stage at the alternate control, the only difference is that, the load current is flowed only through one bridge, the one W_2'' semi-winding, and the key 6.

The second stage of the algorithm, that is, the voltage rise to its normal value, is flowed in the following sequence: simultaneously, the bridge 2 (e.g. up to α_{\max}) is locked, and the unlocking control pulses are removed from the key 6; after the current decay, the key 5 is being switched on, and the steering angle α by the bridge 2 is being decreased from α_{\max} down to $\alpha = \pi/3$, that is, the $0,5Ud_0$ voltage is being restored at the corresponding load. Subsequently, there is the regulation of the load voltage in the range of $0,5Ud < Ud < 0,9Ud$. So, the time described the switching is not practically exceeded $0,02$ s, so the break in the voltage is not only affected on the powerful electric drives DC or the AC, but also to any other inertial load of the above – mentioned power range (e.g. the heating ovens, the different electro – technological installations and etc.).

Thus, the calculations obtained have been shown, that if to do not two, but three of the branch line ($n = 3$) with outlets on three keys in the secondary winding, then $\overline{\cos \varphi_1} = 0,86$, $Km = 0,82$ and the installation are not almost required the reactive power compensation. For all this, the average current is made up about $2/3$ transducer current with the “classic” alternate control (Figure, B), and the total number of thyristors 21, that is, at three less, than at the two – staged alternate control. The \overline{Cn} offset towards larger values is practically increased $\overline{\cos \varphi_1}$ and Km .

Summary

1. The $\overline{\cos \varphi_1}$ commonly – accepted definition, as the ratio of the EMF of the adjustable thyristor transducer to the EMF idling at the zero angle of the control does not consider, that the transducer – is the element of the closed system of the automatic control. To its turn, this is practically led to the $\overline{\cos \varphi_1}$ actual overestimation against the actual one. So, the well – known alternate two – staged control of the thyristor transducers can be allowed to be increased the average power factor from $0,43$ (e.g. at the symmetric control) up to $0,68$.

2. The new system of the alternate control has been suggested, that even in the three – staged option is quite simpler “classic” alternate control, and it, moreover, is practically provided the average power factor $0,82$ in the range of the rectified voltage from the zero up to the nominal one. So, the system is recommended for the power variable voltage DC power inertial loads above 500 kW (e.g. the Electro-technology, the Electro-metallurgy, the Electric drive, and etc.).

References

- Magazinnik G.G., Magazinnik L.T. The Rectifier with Forced Switching. A.S. USSR № 519832, published on 30.06.76. Bulletin, № 24.
- The Transducer with the Artificial Valve Switching. A.S. USSR № 987759, published on 07.01.83. № 1. The Author G.G. Magazinnik.
- Magazinnik L.T. The Frequency Electric Drive. The Russian Patent № 2407141. № 35. 20.10.2010.
- Magazinnik G.G., Melnikov V.L. The Maximum Power Factor Controlled Rectifier. Proceedings of the Institute of Higher Education // Technical Electrodynamics. – 1984 – № 3. – P. 38–43.