

*Medical and Biological sciences**Articles*

<b>MICROBIAL LARVICIDES FOR MALARIA CONTROL IN THE GAMBIA</b> Majambere S., W Lindsay S., Green C., Kandeh B., Fillinger U.	4
<b>PREDICTORS OF DISEASE PROGRESSION IN HIV INFECTION: A REVIEW</b> Langford S. E., Ananworanich J., Cooper D. A.	21
<b>NEW PROSPECTS FOR THE THERAPY OF THE PATIENTS WITH DISSEMINATED MAMMARY CARCINOMA</b> Lokhov R. Ye.	42
<b>AGE-DEPENDENT INDUCTION OF IMMUNITY AND SUBSEQUENT SURVIVAL COSTS IN MALES AND FEMALES OF A TEMPERATE DAMSELFLY</b> Robb T., Forbes M. R.	52
<b>SEASONAL BIORHYTHMS AS A FEATURE OF HUMAN GENETIC SYSTEMS</b> Talalaeva G.V., Khokhutkin I.M.	68
<b>DETERMINATION OF THE GENETIC STRUCTURE OF REMNANT <i>MORUS BONINENSIS</i> KOIDZ. TREES TO ESTABLISH A CONSERVATION PROGRAM ON THE BONIN ISLANDS, JAPAN</b> Tani N., Yoshimaru H., Kawahara T., Hoshi Y., Nobushima F., Yasui T.	74
<b>BK VIRUS ASSOCIATED MENINGOENCEPHALITIS IN AN AIDS PATIENT TREATED WITH HAART</b> Vidal J. E., Fink M. C., Cedeno-Laurent F., Delbue S., Ferrante P., Dauar R. F., Filho F. B., Nogueira R. S., Calore E. E., Pannuti C. S., Trujillo J. R., Penalva de Oliveira A. C.	88

*Materials of the Conferences*

<b>HORMONE-ADAPTIVE-METABOLIC MODEL OF CHRONIC NON-INFECTIOUS DISEASE FORMATION – NEW CONCEPT OF PREVENTIVE MEDICINE</b> Grigorenko A.P., Khoshchenko Yu.A.	95
<b>EVALUATION OF THROMBOCYTE CAPACITY AS METHOD OF EARLY DIAGNOSTICS OF HEMORRHAGIC SYNDROME AT CRIMEAN-CONGO HEMORRHAGIC FEVER</b> Lazareva Ye.N., Samotrueva M.A.	99
<b>METABOLIC AND CIRCULATORY DYNAMICS DISORDERS IN TEENAGE GIRLS WITH OLIGOMENORRHEA AND SECONDARY AMENORRHEA</b> Levenets S.O., Nachetova T.A., Vvedenskaya T.S.	100
<b>PSYCHOPHYSIOLOGICAL STATE OF NAVAL SPECIALISTS IN THE PERIOD OF ACUTE ADAPTATION TO SERVICE UNDER CONTRACT</b> Mosyagin I.G.	101
<b>SEASONAL ACTIVITY CHANGES OF CARBOHYDRATE-ENERGY AND PROTEIN METABOLISM TISSUE ENZYMES IN BLOOD OF NON-ADULTS LIVING IN CONDITIONS OF A PLAIN</b> Nikitina V.V., Abdulnatipov A.I., Sharapkikova P.A.	103
<b>ADVANTAGES AND DISADVANTAGES OF ENERGY PLENTIFUL SUPPLY IN ANIMALS' ORGANISM</b> Testov B.V.	104
<b>MODERN METHODS OF PSYCHOPHYSIOLOGICAL CORRECTION</b> Urazayeva F.Kh., Urazayev Kh.F., Dashkina A.A., Khamzina A.F.	107
<b>AGE-DEPENDENT DYNAMICS OF ELECTROENCEPHALOGRAPHIC CHARACTERISTICS IN IDIOPATHIC ARTERIAL HYPOTENSION PERSONS</b> Chefranova Zh. Yu., Titova L.P., Makotrova T.A.	109

*Shot report***IMMUNE FUNCTIONS OF THE BRAIN**

Parakhonsky A.P.

113

**ROLE OF IMMUNE DAMAGES IN THE NEUROLOGIC PATHOLOGY**

Parakhonsky A.P.

115

*Physico- Mathematical sciences**Shot report***DEDUCTION OF EUCLID STATEMENT ABOUT PARALLEL LINES INTERSECTION AS THEOREM**

Lokhov R. Ye.

118

**EVIDENCE FOR DETERMINATION PRINCIPLE IN TERMS OF PHOTOSYNTHESIS**

Lokhov R. Ye.

122

*Pedagogical sciences**Materials of the Conferences***THE DYNAMICS OF CLINICAL HEALTH OF THE COHORT GROUP EXPOSED TO CHLORANATED DOSES OF TCDD**

Basharova GR, Karamova LM

123

**EDUCATION IN OPEN SOCIETY: PROBLEMS OF VARIABILITY**

Dudina M.N.

129

**COMPARATIVE CHARACTERISTICS OF HEALTH STATUS OF PARENTS EXPOSED TO CHLORENATED DOSES OF TCDD AND OF THEIR CHILDREN**

Karamova L.M., Basharova G., Pyanova F.Z.

132

**CREATIVENESS (“TVORCHESTVO”) AND CREATIVITY: AN ANTHROPOLOGICAL THEORY**

Petrova V.N., Petrov A.

136

**ON FORMATION OF PROFESSIONAL ACTIVITY STANDARDS IN THE SPHERE OF CONSUMER SERVICES**

Rudnik S.Yu.

138

**ON PROJECTING AND PRACTICAL APPLICATION OF INTELLECTUAL TEACHING SYSTEMS AT SPECIALIST TRAINING IN THE AREA OF INFORMATION SECURITY**

Rukovishikova S.N., Gritsyk V.A.

139

**INTEGRATION PROCESS AS CONDITION OF PROFESSIONAL COMPETENCE FORMATION**

Shekikhacheva N.I.

140

*Technical sciences**Articles***METALS FRACTURE MICRO MECHANISM AND PLASTIC ZONES FORMATION AT THE CRACK TIP**

Klevtsov G. V., Klevtsova N. A., Frolova O.A.

142

*Materials of the Conferences***ANALYSIS OF STRESS AND STRAIN STATE OF PLATES AND SHELLS WITH DUE CONSIDERATION OF MATERIALS DAMAGEABILITY THANKS TO TIME-DEPENDENT DEFORMATION AND HIGH-TEMPERATURE HYDROGEN CORROSION**

Belov A.V., Polivanov A.A., Popov A.G.

148

**SECONDARY POWER SOURCES WITH CAPACITORS IN POWER CIRCUIT**

Magazinnik L.T.

150

**TRANSISTOR CHOPPERS FOR ELECTRIC-ARC WELDING**

Magazinnik L.T.

151

**EFFICIENCY OF MODELING NUMERICAL METHODS USE FOR ANALYSIS OF TEXTILE EQUIPMENT WORK INTENSITY**

Nazarova M.V., Bereznyak M.G.

**153****VEGETATIVE REACTIONS TO VESTIBULAR IRRITATION AT SKI JUMPING PRACTICE**

Chinkin A.S., Husnullina R. I.

**156***Economic sciences**Materials of the Conferences***MODERN CONCEPTS OF MONEY FLOWS CONTROL ON BASIS OF ACCOUNTING INFORMATION**

Khakhonova N.N.

**158**

## MICROBIAL LARVICIDES FOR MALARIA CONTROL IN THE GAMBIA

Majambere S.<sup>1,2</sup>, W Lindsay S.<sup>1</sup>, Green C.<sup>1,2</sup>, Kandeh B.<sup>3</sup>, Fillinger U.<sup>1</sup>

<sup>1</sup>School of Biological and Biomedical Sciences, Durham University  
Durham, DH1 3LE, UK

<sup>2</sup>Medical Research Council Laboratories, Fajara, The Gambia and

<sup>3</sup>National Malaria Control Programme, Banjul, The Gambia

Mosquito larval control may prove to be an effective tool for incorporating into integrated vector management (IVM) strategies for reducing malaria transmission. Here the efficacy of microbial larvicides against *Anopheles gambiae* s.l. was tested in preparation for a large-scale larviciding programme in The Gambia.

The impact of water-dispersible (WDG) and corn granule (CG) formulations of commercial *Bacillus sphaericus* strain 2362 (*Bs*; VectoLex<sup>®</sup>) and *Bacillus thuringiensis* var. *israelensis* strain AM65-52 (*Bti*; VectoBac<sup>®</sup>) on larval development were tested under laboratory and field conditions to (1) identify the susceptibility of local vectors, (2) evaluate the residual effect and re-treatment intervals, (3) test the effectiveness of the microbials under operational application conditions and (4) develop a method for large-scale application.

The major malaria vectors were highly susceptible to both microbials. The lethal concentration (LC) to kill 95% of third instar larvae of *Anopheles gambiae* s.s. after 24 hours was 0.023 mg/l (14.9 BsITU/l) for *Bs* WDG and 0.132 mg/l (396 ITU/l) for *Bti* WDG. In general *Bs* had little residual effect under field conditions even when the application rate was 200 times greater than the LC<sub>95</sub>. However, there was a residual effect up to 10 days in standardized field tests implemented during the dry season. Both microbials achieved 100% mortality of larvae 24–48 hours post-application but late instar larvae were detected 4 days after treatment. Pupae development was reduced by 94% (95% Confidence Interval = 90.8–97.5%) at weekly re-treatment intervals. Field tests showed that *Bs* had no residual activity against anopheline larvae. Both microbials provided complete protection when applied weekly. The basic training of personnel in identification of habitats, calibration of application equipment and active larviciding proved to be successful and achieved full coverage and control of mosquito larvae for three months under fully operational conditions.

Environmentally safe microbial larvicides can significantly reduce larval abundance in the natural habitats of The Gambia and could be a useful tool for inclusion in an IVM programme. The costs of the intervention in this setting could be reduced with formulations that provide a greater residual effect.

### Background

At the start of the new millennium malaria is still deeply entrenched in Africa and effective malaria control is under threat from drug and insecticide resistance [ 1 , 2 ]. In response to that, mosquito larval control has recently received renewed attention by the international scientific community [ 3 - 11 ] and recent attempts to develop integrated vector management (IVM) strategies for different eco-epidemiological settings re-consider mosquito larval control as one of the tools to reduce malaria transmission [ 12 ].

Promising new formulations of the microbial larvicides *Bacillus sphaericus* (*Bs*) and *B. thuringiensis* var. *israelensis* (*Bti*) have recently been shown to give excellent

control of the major vectors of malaria in Africa [ 4, 13 ]. Use of these biological control agents is better than chemical larvicides since they are very species specific, environmentally safe

[ 14 ] and appear not to induce resistance when used together [15]. It is envisaged that the utilization of such biological control agents may be best carried out using a vertical approach that actively involves local communities [ 10 , 16 ].

The national strategy for malaria control in The Gambia includes larval control [17], yet there has been no detailed evaluation of this methodology. Whilst *Bs* and *Bti* have been tested in different ecological settings in Africa [4,18 22 ], the

riparian habitats found in The Gambia represent a novel habitat for investigating these microbials. In the presented study the efficacy of microbial larvicides was tested against malaria vectors in The Gambia, West Africa, to identify the optimal formulations, dosages and application methods in order to prepare for a large-scale larviciding programme.

### Methods

#### Study area

The Gambia is in the southern Sahel and is characterized by a single rainy season from June to October. The country lies in an area of open flat Sudan savannah that is dominated by the River Gambia, a large, slow moving waterway, characterized by tidal movements and saltwater intrusions as far as 200 km up river. River Gambia is representative of many large river systems in Africa. Its tidal movements flood successive belts of vegetation from the mangrove forest through flooded *Phragmites*, sedge and grass species, punctuated by large bands of barren floodplain. The tidal movement of the river and its flooding during the rainy season creates suitable breeding habitats for malaria vectors [ 23 , 24 ].

The study was based in and around Farafenni town (UTM zone 28 1500200mN, 435500mE), in the central part of the country, about 100 km from the coast (Figure 1). Laboratory and standardized field tests were carried out at Farafenni Field Station of the Medical Research Council (MRC) Laboratories. Field tests were implemented near Tamba-Koto village, 10 km east of Farafenni. The area is predominantly flat farmland and woodland savannah. The main inland crops are sorghum, millet, groundnut and pumpkin and in the floodplains swamps rice is grown during the rainy season. The villages in the area are discrete clusters of houses and are not scattered as seen in many parts of Africa. The primary malaria vectors are *Anopheles gambiae sensu stricto*, *Anopheles arabiensis* and *Anopheles melas* [ 23 , 25 ].

#### Climate

Data on daily minimum and maximum temperatures were available from the meteorological station at Kaur 30 km from Farafenni town. Rainfall was collected with a rain gauge at the MRC station, Farafenni.

#### Larvicides

Water-dispersible granular formulations (WG/WDG) of the commercial strains of *Bs* (VectoLex<sup>®</sup> strain 2362, Lot number 115-498-PG, 650 International Toxic Units, ITU/ mg) and *Bti* (VectoBac<sup>®</sup> strain AM65-52; Lot number 114114-32, 3000 ITU/mg; Valent BioSciences Corporation, Illinois, USA,) were tested in the laboratory and under field conditions, in a similar manner to that described by Fillinger *et al.* [ 13 ] in Kenya, in order to make direct comparisons between west and east Africa. WG/WDG formulations were applied as liquid with handheld or knapsack sprayers. *Bs* (VectoLex<sup>®</sup>, Lot number 117-999-NB, 50 ITU/ mg) and *Bti* (VectoBac<sup>®</sup>, Lot number 131-661-NB, 200 ITU/mg) corn granule (CG) for hand application or motorized granule spreaders was evaluated under field conditions only.

#### Laboratory assays

Laboratory assays were conducted to assess the susceptibility of the principal malaria vector in The Gambia, *An. gambiae* s.s., to microbial larvicides. Laboratory assays were carried out with a colony of insectary-reared larvae originated derived from wild-caught mosquitoes collected from Saruja in The Gambia and maintained at the MRC Laboratory in Farafenni since 2002. All mosquito larvae used in the laboratory experiments were reared at a room temperature of 28°C, 80% relative humidity and an approximate 12 hour light : 12 hour dark cycle. Larvae were reared in transparent, 1.5 L capacity plastic containers (24 × 17 × 8 cm) filled with 1 L tap water that had been left in the insectary for at least 48 hours to equilibrate. Larvae were fed by adding a pinch of crushed Tetramin<sup>®</sup> (Tetra, Germany) fish food spread evenly on the water surface twice daily.

**Figure 1.** Map of The Gambia, West Africa (A) and the study area (B). The black line encloses the control, the red line the intervention area. The 24 sentinel sites for larval surveys are marked as stars.

Assays were performed with the WG/WDG formulation of VectoLex<sup>®</sup> and VectoBac<sup>®</sup> to determine their minimum effective dosages following the standard testing procedures for microbial tests [14]. Fifty third instar larvae were randomly collected for the experiment from several bowls to compensate for size differences that could have reflected the amount of food available [26] and transferred to new 1.5 L plastic containers filled with 1 L of the test solution or distilled water only (control). On every test date a fresh stock solution of 100 mg/l WG/WDG was prepared and test

aliquots made up to 1 L with distilled water. After range finding tests [14], five to six different test concentrations were chosen for each experiment. Test concentrations ranged between 0.001 and 0.1 p.p.m for *Bs* and between 0.001 and 0.016 p.p.m for *Bti*. Each experiment contained an untreated control. The experiment was run in three replicates at the same time and the entire experiment carried out on five occasions. Larvae were not fed during the experiments and all tests were run at ambient temperature ranging between 21 and 34°C. Larvae were counted and mortality scored after 24 hours. Where

mortality exceeded 10% in the controls, the experiment was discarded and repeated.

#### Standardized field trials

Standardized field trials were conducted at the MRC field station in Farafenni during the rainy (September to October 2004) and dry season (December 2004 to May 2005) to identify the optimum dosages of *Bs* and *Bti* required under field conditions and to evaluate the residual effect and re-treatment intervals for the test microbials. Artificial ponds were created following the experimental design of Fillinger *et al.* [13]. Eighteen light blue plastic tubs (0.5 m diameter) were buried into an open sunlit field in three lines of six tubs (distances between tubs was approximately 2 m). The tubs were filled with approximately 6 kg of top soil from the experimental area to provide the abiotic and biotic conditions suitable for mosquitoes. Tub s were filled with tap water and maintained at a depth of 0.4

m. Overflow holes were created at the 0.4 m level and screened with nylon netting to allow excess water to leave the tubs during heavy rainfall and prevent larvae from being washed over the edges. The habitats were left open for mosquito oviposition. Experiments were implemented eight to nine days after the tubs were set-up to allow third and fourth instar larvae to develop. Water temperatures during the experiments ranged between a minimum of 23°C and a maximum of 40°C. Acknowledging the hazard artificially created breeding sites present, all habitats were carefully screened for pupae twice daily with a dipper and visually and any pupae were removed vent the emergence of malaria vectors.

Of the 18 artificial habitats, six served as untreated controls and two treatments (six tubs each) were also the remaining 12. Treatment and control selected randomly using a web-

based random [27]. Treatment concentrations were calculated on a basis of a standard water depth of 0.1 m and fixed area [28, 29] irrespective of the actual water depth used in operational procedures. Both microbials were applied over the entire water surface of the habitats using a 250 ml handheld sprayer. Each day the average number of larvae and pupae per dip (350 ml capacity dipper, Clarke Mosquito Control Products, Illinois, USA) was determined by taking five dips from four different directions of each pond close to the edge and one from the middle. Mosquito larvae were classified as anophelines or culicines and recorded as early (1<sup>st</sup> and 2<sup>nd</sup>) or late (3<sup>rd</sup> and 4<sup>th</sup>) instars. After counting, larvae were returned to the water and pupae removed. Treatment was done once at day 0. The experiment was terminated when the difference between late instar and pupae density was no longer statistically significant between control and treatment tubs. A subsample of 69 *Anopheles* adults were allowed to emerge from pupae collected from the control and identified morphologically; rDNA-PCR markers were used for species determination of adults of the *An. gambiae* species complex [30].

#### Field trial

Based on the results from the laboratory and the standardized field tests a pilot-scale field operation was designed and implemented between August and November 2005 to test the efficiency and life span of the larvicides under natural conditions in representative habitat types in the floodplains of the River Gambia. The field tests served to identify (1) the operational requirements e.g. time needed per surface area treated, equipment and manpower needed, (2) the optimal microbial and (3) the best formulation in preparation for large-scale larviciding campaigns scheduled for the following rainy season 2006.

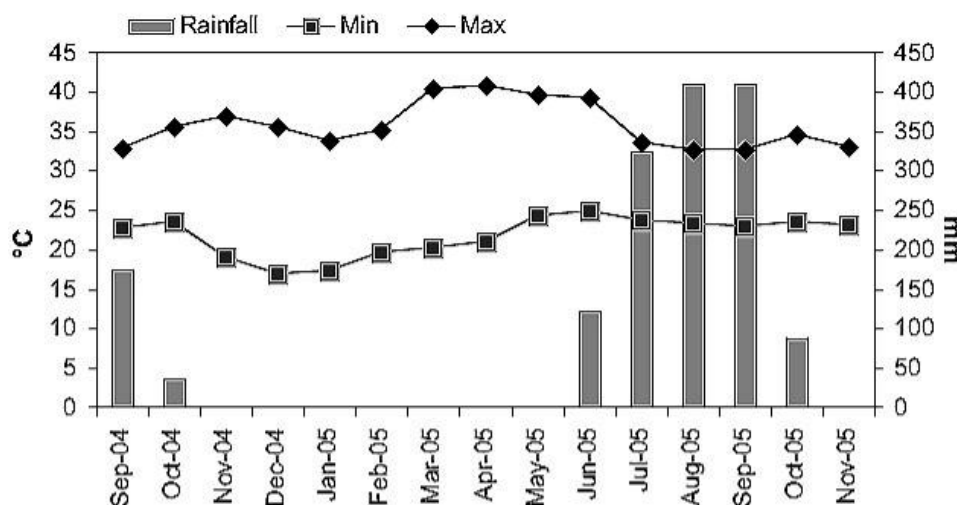

Figure 2. Temperature (°C) and rainfall pattern (mm) during the studyperiod.

Liquid (WDG) and granule (CG) formulations of both *Bs* and *Bti* were tested. Liquids were applied using 5 L capacity compression sprayers (Mesto Resistent No. 3600, Freiberg, Germany) or 15 L capacity diaphragm knapsack sprayers (SOLO® 475, Sindelfingen, Germany; Figure 3). Both sprayers were operated at an average pressure of 4bar. Corn granules were either applied by hand carrying the granules in a 5 L bucket on a carrying strap over the shoulder (Figure 4) or were spread with 13 L backpack power chemical applicators (MD 150DX-13 Maruyama, Tokyo, Japan) covering a swath width of 10–15 metres.

The pilot zone was situated 10 km east of Farafenni and had an area of 24 km<sup>2</sup>. The area included the major breeding habitats for anophelines in this region of The Gambia: extensive rice fields, pools that were people-made and natural, and large floodwater areas interspersed with grass. Notably, aquatic habitats harbouring anopheline larvae in the Gambia might be described as 'atypical' when compared with other parts of Africa. The habitats are water-fed primarily through the flooding of the river and are additionally under tidal influence leading to flooding and contraction of the habitats which are usually shallow but can be extensive in size (Figure

3) and are probably fairly typical for many large rivers in the Sahel.

After mapping all aquatic habitats in the pilot zone the area was divided into an intervention and a non-intervention zone (Figure 1). In the intervention zone, 6 km<sup>2</sup> was routinely larvicided. In each zone 12 sentinel sites were randomly selected from the total list of habitats for measuring mosquito larval density. The sentinel sites were located in rice fields and floodwater habitats covered with grass and sedge. Larviciding was implemented under operational conditions by a team of four men from the National Malaria Control Programme who had undergone two weeks of training prior to the field trial. The monitoring of the intervention's impact in the 24 sentinel sites was implemented independently by the research team. The larviciding teams were unaware of the location of the sentinel sites.

*Bs* treatments were applied at rates of 1 kg/ha for WDG and 15 kg/ha for CG; dosages proven to be effective from the standardized field trials and previous experiences [ 4 , 13 ]. *Bs* WDG was tested for two consecutive weeks and followed by *Bs* CG for one week. This allowed the authors to train larviciding staff how to use different application equipment and assess



whether the two formulations performed differently under field conditions. Larval density was surveyed using the standard dipping technique [31]. Ten dips were taken at each sentinel site to determine the larval density at the day of the first treatment (day 0) and at day two, four and seven after treatment for three consecutive weeks. Purposive sampling was done to maximise the sensitivity of collections. Re-treatments took place on a weekly basis if late instar larvae occurred at day four.

Following the *Bs* field test, operational application of *Bti* was evaluated at dosages of 4.0 kg/ha for CG for two weeks, followed by WDG applications of 0.2 kg/ha for seven weeks. Dosages were based on laboratory and field trial results and on previous studies [4,13]. During the application of *Bti* larval density was monitored once a week in the sentinel sites using the same methodology as described above. The monitoring was implemented one to three days after application.

Due to the specific habitat characteristics in the tidal floodwater of The River Gambia we covered the entire surface of all aquatic habitats with larvicide.



**Figure 4.** Hand application of corn granule in highly vegetated areas of the floodplains.

#### Analyses

LC<sub>50</sub> and LC<sub>99</sub> values were determined using log-probit regression analysis. The percentage reduction in larval mosquito densities in the standardized field trials was

calculated using the formula of Mulla *et al.* [ 32 ]: % Reduction = 100 - (C<sub>1</sub>/T<sub>1</sub> × T<sub>2</sub>/C<sub>2</sub>) ×100, where C<sub>1</sub> and C<sub>2</sub> describe the average number of larvae in the control tubs pre- and post-treatment, T<sub>1</sub> and T<sub>2</sub> describe the average number of larvae in the treated tubs pre-and post-treatment



**Figure 3.** Liquid application of microbial larvicides with 15 litres capacity knapsack sprayers on open water surface (edge of floodwater).

. Mean number of larvae and pupae per dip in control and treatment sites in field tests were compared using non-parametric Mann-Whitney tests. The tests were implemented separately for each sampling day comparing mean numbers of immature stages in the controls with treatments. When multiple comparisons of more than one treatment and control were made the Bonferroni correction was used to define the alpha cut off value. The corrected significance levels are presented with the figures. All analyses were carried out using version 11.0 of the SPSS statistical software package.

#### Ethics

Ethical approval for this study was given by the Joint Gambian Government and Medical Research Council's Laboratories in The Gambia, as well as Durham University's Ethics Advisory Committee.

## Results

### Climate

Figure 2 summarizes average minimum and maximum temperatures and the monthly rainfall during the study period from September 2004 to November 2005. The dry season extended from November 2004 to May 2005 and can be portioned into a 'cold dry season', from November to February, and a 'hot dry season', from March to May. The rainy season is characterized by more constant temperatures with little difference between minimum and maximum values. Rain fell only once during the experiments on day 4 of the rainy season test of low (0.5 and 1 kg/ha) *Bs* WDG dosages, but did not appear to influence the results.

### Laboratory assays

After 24 hours exposure of third instar larvae of *An. gambiae* s.s. to *Bs* WDG (VectoLex<sup>®</sup>, 650 BsITU/mg), a concentration of 0.004 mg/l (2.6 BsITU/l) caused 50% mortality (LC<sub>50</sub>) and a concentration of 0.023 mg/l (14.9 BsITU/l) caused 95% mortality (LC<sub>95</sub>). *Bti* WDG (VectoBac<sup>®</sup>, 3000 ITU/mg) concentrations of 0.039 mg/l (117 ITU/l) killed 50% of the larvae and 0.132 mg/l (396 ITU/l) 95% (Table 1).

### Standardized field trials

Throughout the year, oviposition occurred soon after the artificial habitats were set up and immature stages of anopheline and culicine mosquitoes detected after four to five days. Overall *Anopheles* larvae accounted for 40% of larvae collected during the trials. 69 *Anopheles* adults that emerged from pupae collected from the control tubs were identified to species level. 36 *Anopheles* adults belonged to the *An. gambiae* s.l. species complex and PCR analyses revealed that the tubs contained a mix of *An. arabiensis* (66%), *An. gambiae* s.s. (30%) and *An. melas* (4%). Since there were no differences of the impact of the larvicides on anophelines and culicines in the standardized field trials the data were pooled for all analyses and presentation.

### *Bti* WG

Field trials with *Bti* WG were implemented with the minimum dosage [33] required to cause 100% mortality within 24–48 hours after application as identified in the laboratory assays. Since no improvement of the impact or activation of any residual effect was expected [34] higher dosages were not tested after the minimum dosage of 0.2 kg/ha under standardized field conditions killed all larvae within 48 hours and provided therefore optimum control for the period of one week (Figure 5 and Table 2). Although reduced late instar densities were recorded up to eight to ten days after application (Table 2) these differences were only statistically significant up to day five (Figure 5) in both test periods. Late instar larvae and pupae developed in increasing numbers five to six days after *Bti* application. The seasons had little impact on the outcome of the trials. Notably, pupal production could not be completely suppressed despite the well-controlled implementation of the experiment, although pupal production was more successfully suppressed during the cold than the hot dry season. The results indicate that weekly treatment intervals can reduce pupae production by 64–94%. A recent study though showed that higher rates of the WG formulation of *Bti* may produce longer control since the WG particles redistribute throughout the water column after application (S. Krause, personal communication) and, therefore, the effect of higher *Bti* WG rates on field residual control of *An. gambiae* requires further study.

### *Bs* WDG

Four different doses of *Bs* WDG were tested (0.5, 1.0, 2.5 and 5.0 kg/ha) and each experiment run twice to evaluate whether any residual effect of the larvicide could be detected which would allow extended re-treatment intervals. The results of the impact of the different dosages are presented in Figure 6 and 7. The results are shown separately for the replicates implemented during the rainy (A) and the dry season (B). The

daily percent reduction of late instar larvae is summarized in Table 3.

Irrespective of dosage and season 96–100% larval mortality was achieved 24–48 hours after application. No residual effect of a single Bs application was detected during the rainy season at any application rate tested but was extended during the dry season for all tested dosages (Figure 5 and 6, Table 3). Statistically significant reductions in pupae densities were achieved up to five days post-

treatment in the rainy season and up to 10 days during the dry season. There were no statistically significant differences between the different test concentrations (Figure 6 and 7). Consequently, pupae development could be reduced by over 95% when Bs WDG was applied at weekly intervals. Low dosages have shown to be as effective as high dosages. During the dry season similar suppression of pupae densities could be achieved at 10-day re-treatment intervals.

**Table 1.** Laboratory bioassays results of *Bs* and *Bti* WDG/WG against third instar larvae of *Anopheles gambiae* s.s. after 24 h exposure (lethal concentrations (LC) in p.p.m.)

WDG/WG Formulations	LC <sub>50</sub> (95% CI)	LC <sub>95</sub> (95% CI)	Slope (SE)	c <sup>2</sup> (d.f.)
VectoLex (650 BslTU/mg)	0.004 (0.003<LC<0.005)	0.023 (0.016<LC<0.042)	2.208 (0.112)	123.518 (25)
VectoBac (3000 ITU/mg)	0.039 (0.033<LC<0.047)	0.132 (0.100<LC<0.199)	3.110 (0.141)	140.513 (23)

CI, confidence interval; SE, standard error; d.f., degrees of freedom

#### Field trial

Field trials were conducted in the floodplains of the River Gambia to confirm results from standardized field set up and to evaluate the effect of larviciding under operational conditions. The field tests were implemented during the rainy season which is the main malaria transmission season in The Gambia and the period with most larval habitats. At the start of the field trials late instar *Anopheles* larvae were found in 33% of all sentinel sites. The proportion of habitats with late instar *Anopheles* increased in the non-intervention sites with continuous rainfall to 67% in October 2005. Culicine and anopheline larvae co-existed in most of the habitats and did not show any difference in response to the larviciding. Both sub-families have, therefore, been pooled for presentation and analyses.

*Bs* WDG and CG formulations were evaluated to detect any residual effect of the microbial under operational application in the field. Application took place at weekly intervals to evaluate whether continuous application might result in an increasing residual effect with time. The results of the three week trial are presented in Figure 8. 100% mortality of late instar larvae was

achieved two days post-treatment at any application date irrespective of the formulation applied. A residual effect of the microbial which would allow re-treatment intervals greater than one week was not detected (Figure 8), which supports the results from the standardized field trials. Weekly application of *Bti* under operational conditions (Figure 9 ) achieved a consistent suppression of larval development over the entire nine weeks study period with minimum dosages (as identified in laboratory) irrespective of the formulation and equipment used. Surprisingly, pupae were not collected under field conditions in either the intervention or control sites.

Larvicides were applied by four men from 7:00 to 13:00 (6 hours) a day. While staff worked continuously to cover the entire study area, each habitat was sprayed only once a week. All formulations could be successfully applied under operational conditions and were equally effective. Different application equipment though had an impact on the time required per surface area treated. On average seven hectares were treated per day (0.29 ha/person/hour) using 5 L compression sprayers or 13 L motorised granule spreaders; nine hectares were

covered using 15 L knapsack sprayers (0.38 granules were applied by hand (0.21 ha/ person/ hour) and 5 hectares when ha/person/hour).

**Table 2.** Percent reduction (%) of late instar larvae (*Anopheles* and culicine combined) after application of *Bti* WDG at 0.2 kg/ha in the cold (Dec) and hot (May) dry season

Day after application	Cold dry season	Hot dry season
1	100	95
2	100	100
3	100	95
4	100	94
5	98	81
6	90	54
7	67	68
8	45	68
9	0	33
10	0	74

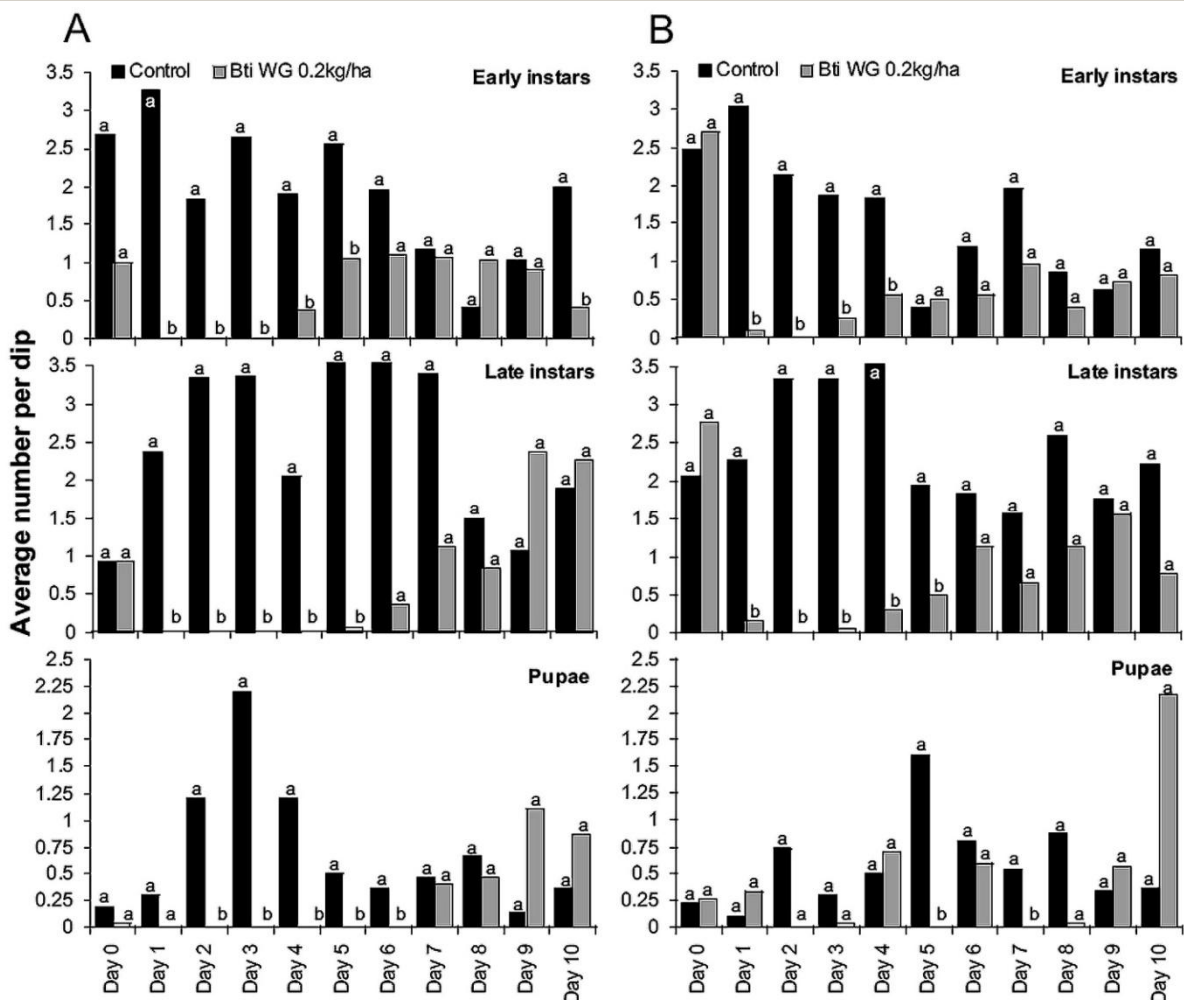
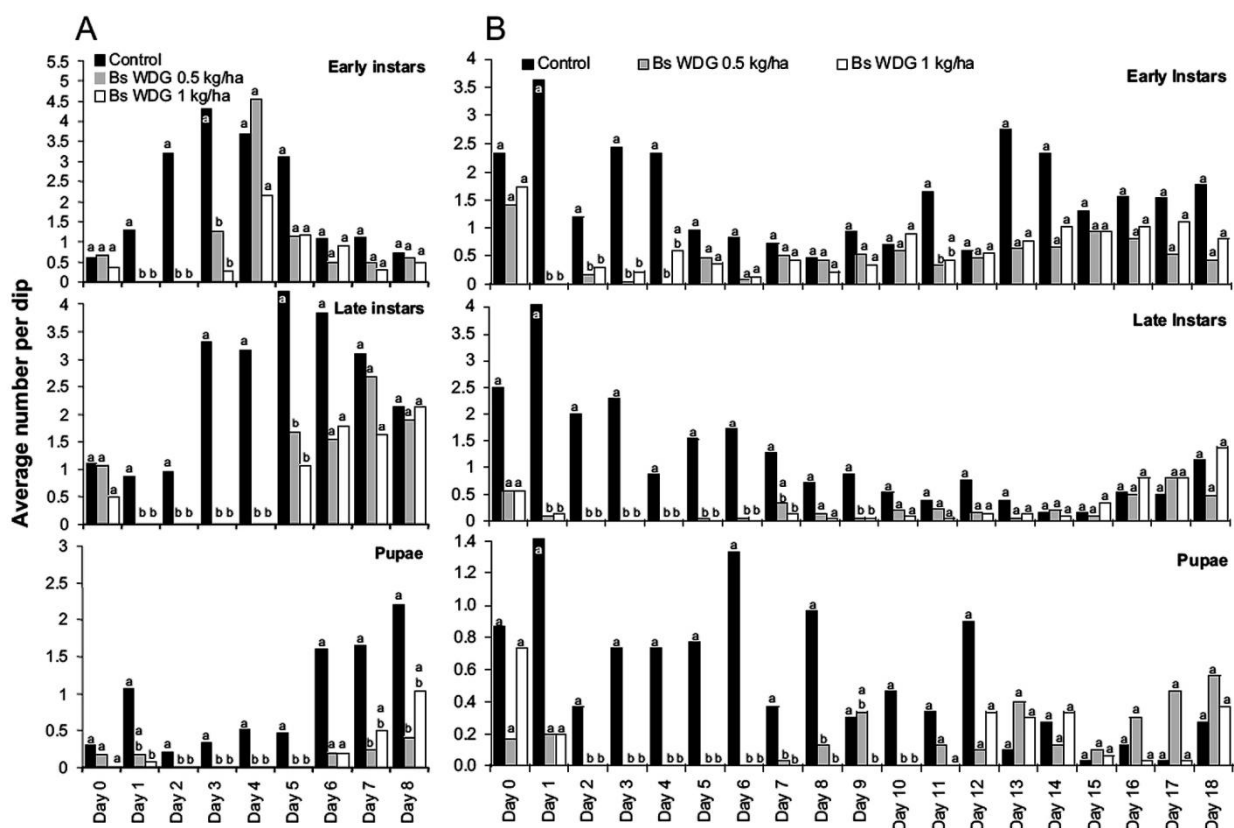

**Figure 5.** Impact of *Bti* WDG at 0.2 kg/ha on early and late larval and pupae density in standardized field tests. A: during cold dry season (Dec); B: during hot dry season (May). Daily differences in immature densities were analysed using Mann-Whitney tests at a significance level of  $p < 0.05$ . Different letters (a, b) on bars indicate a significant difference at the specific sampling day.

**Discussion**

The results show that the major malaria vectors in The Gambia are highly susceptible to *Bs* and *Bti* under laboratory and field conditions, with *Bs* even more toxic per weight applied than *Bti*. The LC values found in the laboratory experiments are very similar to those found in earlier studies [13,35] conducted in East Africa suggesting that the susceptibility of malaria vectors to microbial larvicides is inherent to the species and not to the ecological settings of the area. *Bs* has shown residual activity for two to 10 weeks

in previous studies [ 36 - 39 ], with repeated applications increasing the likelihood of greater residual activity [ 4 , 40 ]. Larvicides with long residual activity would be advantageous for larviciding campaigns because less manpower and larvicide would be required, helping to keep down costs and increase effectiveness. However, in contrast to previous results *Bs* did not show extended residual effect under field conditions in The Gambia even after repeated treatments and when the application rate was as high as 200 times the LC<sub>95</sub> (5 kg/ha).



**Figure 6.** Impact of low dosages of *Bs* WDG (0.5 and 1 kg/ha) on immature mosquito density in standardized field tests. A: during rainy season; B: during dry season. Daily differences in immature densities were analysed using Mann-Whitney tests at a significance level of  $p < 0.017$ . Different letters (a, b) on bars indicate a significant difference at the specific sampling day.

Only a slightly extended residual effect up to 10 days could be detected in the standardized field tests implemented during the dry season (January to March) but not the wet season. It can be hypothesized that the different daily water temperature profile in

the experimental tubs during the rainy season might be responsible for the reduced effect of the microbial. Although the average air temperatures did not differ between the experimental periods in the rainy and dry seasons the low variation between minimum

and maximum temperatures during the rainy season (Figure 2 ) will have resulted in high water temperatures for longer during the rains compared with the dry season. High water temperatures result in faster destruction of the protein toxin [ 41 ]. The low residual activity could also be due to the low larval density observed in the artificial and natural habitats. *Bs* seems to persist or recycle in some environments because it rapidly increases its numbers in the midgut of killed larvae [42-44]. Where larval densities were high the residual activity of the microbial larvicides appears to be greater [45 , 46 ]. Dead and dying larvae release the bacteria into the water increasing the bacterial content of the water and infecting new generations of larvae.

The presence and abundance of pupae can serve as a proxy measure for adult mosquito emergence, since pupae survive for only a few days before adult emergence. The identification of the most productive habitats for adults could help target larviciding operations especially in the extensive water surface areas of the river's floodplains. In this study no pupae were collected in the field during the pilot field tests. This unexpected finding may be a consequence of the dipping technique. Although the technique is commonly used for studying larval ecology in Africa, it appears to be inappropriate for sampling the very sensitive and agile pupae from natural aquatic habitats, particularly in The Gambia where larval densities are generally low consequently leading to even lower pupae densities. This insensitivity of the sampling technique is further compounded by the highly aggregated distribution of pupae in natural habitats compared to larvae [31,47,48]. Even in the tubs dipping underestimated the density of pupae. Sweep nets may prove to be a better sampling tool since they collect 10 times more pupae in fewer sweeps than dips (see also [47]). Since pupae abundance is often used for establishing the 'productivity' of

habitats [8] further studies to develop more efficient sampling protocols are desirable.

Large-scale application of larvicides in The Gambia will be implemented during the rainy season when the river floods and surface water is plentiful. At the end of the wet season over 90% of the *Anopheles*-containing breeding sites dry up quickly leaving only a few dry season refugia. For these dry season sites a targeted application of *Bs* might be useful to suppress the build up of the adult population at the start of the rains. The results indicate that with commercially available microbials weekly larviciding will be necessary during the rainy season in The Gambia. In this instance the use of *Bti* products is preferred since the costs for this microbial are far lower than *Bs* [ 4 ] and the development of resistance is unlikely [ 15 , 34 , 49 ]. Very low dosages of 0.2 kg/ha (representing the LC<sub>99</sub>) lead to optimal suppression of mosquito larvae and pupae which is consistent with results from East Africa [4,13].

Granule and liquid formulations have proven equally effective in killing mosquito larvae but the selection of application equipment was important for the speed of coverage. The 5 L compression sprayers were easier to carry than the higher capacity sprayers, but they were slower to use because they needed to be refilled more frequently. This was exacerbated by the fact that most water bodies in the floodplains of The Gambia are very shallow and muddy, and, therefore, unsuitable for water collection, which led to long distances being covered to re-fill the sprayers. Another disadvantage of the compression sprayers was that they have to be pressurized by pumping air into the tank before spraying which proved difficult on the very muddy ground in the floodplains. The problem of finding suitable water sources for mixing WDG formulations and the increasing plant growth during the rainy season favours the application of granule formulations in an environment like the river floodplains.

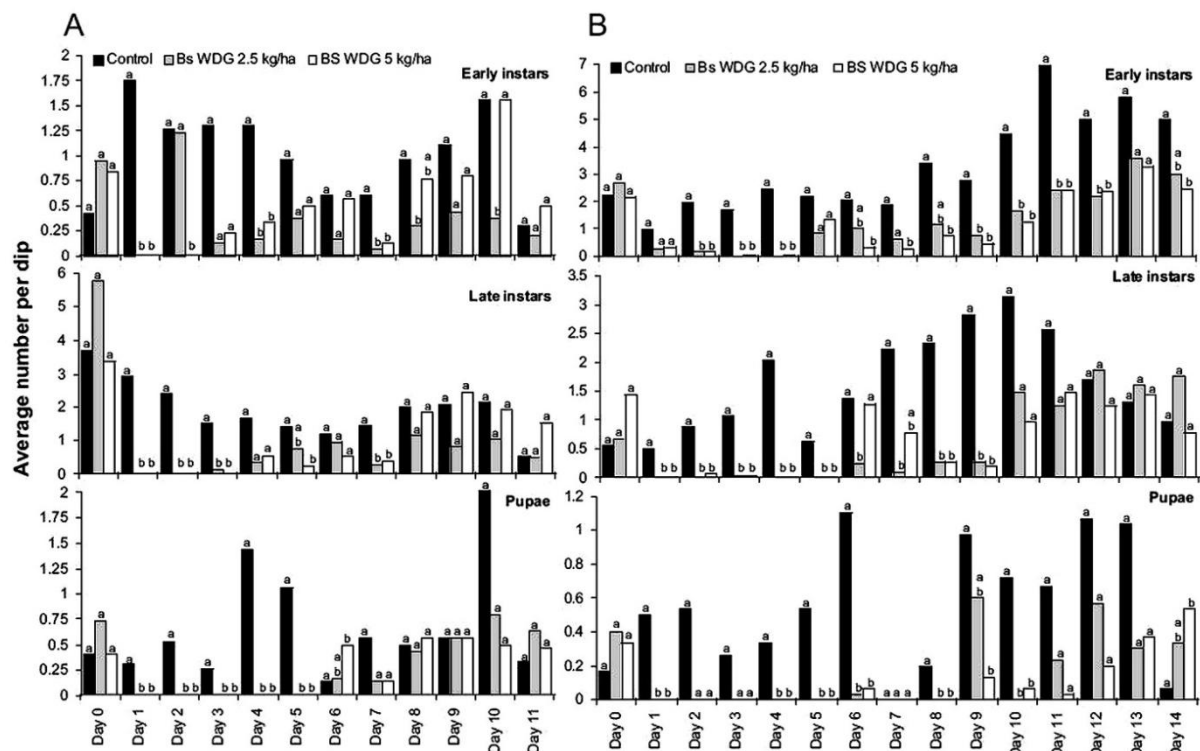

**Figure 7.** Impact of high dosages of *Bs* WDG (2.5 and 5 kg/ha) on immature mosquito density in standardized field tests. A: during rainy season; B: during dry season. Daily differences in immature densities were analysed using Mann-Whitney tests at a significance level of  $p < 0.017$ . Different letters (a, b) on bars indicate a significant difference at the specific sampling day.

**Table 3.** Percent reduction (%) of late instar larvae (*Anopheles* and culicine combined) after application of *Bs* WDG in different dosages in the dry and rainy season

Day after application	Rainy season				Dry season			
	0.5 kg/ha	1.0 kg/ha	2.5 kg/ha	5.0 kg/ha	0.5 kg/ha	1.0 kg/ha	2.5 kg/ha	5.0 kg/ha
1	100	100	100	100	96	96	100	100
2	100	100	96	100	100	100	100	95
3	100	100	89	68	100	100	100	100
4	100	100	68	85	100	100	100	100
5	60	44	52	55	100	100	88	100
6	59	0	86	69	76	100	96	60
7	11	0	62	2	4	68	89	84
8	9	0	74	0	40	100	91	94
9	-	-	70	1	54	54	58	97
10	-	-	36	0	0	17	60	86
11	-	-	-	-	0	0	4	75
12	-	-	-	-	0	48	0	70
13	-	-	-	-	0	0	0	54
14	-	-	-	-	0	0	-	66
15	-	-	-	-	0	0	-	-
16	-	-	-	-	0	0	-	-
17	-	-	-	-	0	0	-	-
18	-	-	-	-	0	0	-	-

-, test was terminated earlier

Motorized granule spreaders provided excellent coverage and proved especially useful in areas with tall vegetation where access on foot is impossible. However, when filled with the microbials they weighed close to 20 kg and walking on soft ground became difficult and, coupled with the loud noise of the engine, made them uncomfortable for long-term use. The relatively high purchase and running costs of motorized spreaders (approximately \$300/spreader plus fuel costs) compared to knapsack sprayers (approximately \$100/sprayer) represent another disadvantage in resource poor African settings. Based on the pilot field trial, it is recommended for a large-scale larviciding programme in The Gambia to use 15 L knapsack sprayers for all large, open water surface areas, and to use granule formulations for highly vegetated areas. In the view of the authors hand application is the preferred method for larvicide application because it represents a low-tech and low-cost technology. Even though granule distribution does not result in an even application, as that achieved with motorized sprayers, it is easily manageable and maintenance free. Nevertheless, motorized sprayers must be used when tall vegetation dominates or access on foot is impossible due to high water level or soft underground.

The basic training of larviciding personnel in identification of habitats, calibration of application equipment and active larviciding proved to be successful and achieved full coverage and control of mosquitoes for three months under fully operational conditions. To reduce labour and management effort though it would be desirable to have larvicides available which would express extended efficiency under extreme climate conditions. Microbial larvicides were chosen in this study because, in contrast to many other larval control agents, they exhibit the highest environmental safety to non-target organisms and application personnel, they are very easy to handle and are unlikely to lead to the

development of resistance [ 15 , 34 , 49 , 50 ]. Nevertheless, it would be useful to explore whether greater persistence could be achieved with alternative products. Organophosphates, like temephos, appear to be less useful since they rarely show much persistence compared with microbials [9,51]. Moreover, organophosphates can have a negative impact on non-target organisms [ 52 , 53 ] and need careful resistance management. On the other hand, the use of insect growth regulators (IGRs), like pyriproxyfen, might prove more advantageous [ 54 - 56 ]. IGRs have been highly successful elsewhere when applied at monthly intervals, although this was usually administered in highly confined habitats [ 56 , 57 ]. Whether this residual effect could be replicated in a highly mobile aquatic environment like the floodplains of The Gambia needs careful evaluation. The greatest disadvantage of IGRs though is the difficulty in monitoring whether they are still effective or not since larvae will always be detected in the water and the development and emergence of pupae needs to be observed, which represents a challenge given the difficulty of collecting any pupae. Moreover complicated monitoring systems using emergence cages or similar devices might not be easy to handle in a large-scale operational programme.

#### Conclusion

The results support the hypothesis that the implementation of large-scale larviciding with commercially available microbials in The Gambia will lead to a reduction in larval abundance in the natural habitats. Both microbial strains tested, can be applied successfully in extended floodplain areas either as liquid with knapsack sprayers or as granules by hand and motorised sprayers. Due to the lack of residual effect of *Bs*, products *Bti* should be applied weekly during the rainy season. Dry season refugia should be targeted with bi-monthly *Bs* applications.



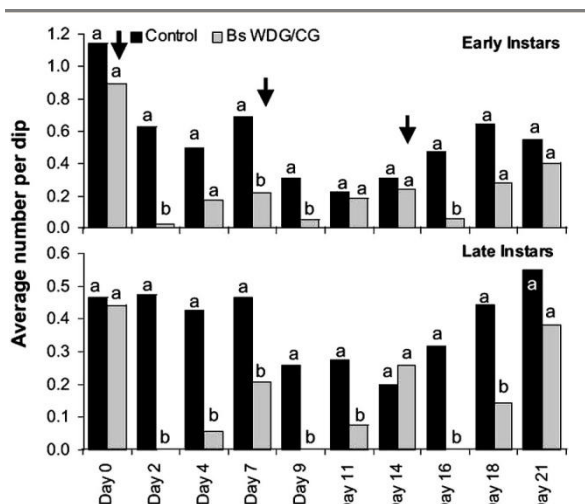

**Figure 8.** Efficiency of *Bs* treatments under operational field conditions. *Bs* application took place on day 0, day 7 and day 14 (arrows). WDG formulation was applied on day 0 and 7; CG formulation was applied on day 14. Differences in immature densities were analysed using Mann-Whitney tests at a significance level of  $p < 0.05$ . Different letters (a, b) on bars indicate a significant difference at the specific sampling date.

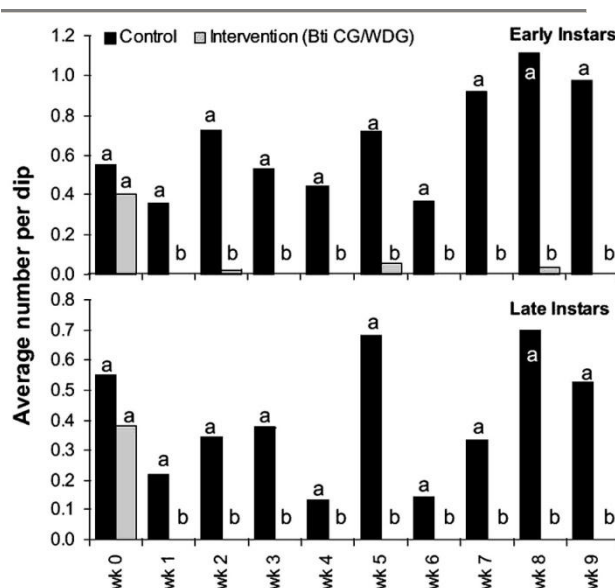

**Figure 9.** Efficiency of *Bti* treatments under operational field conditions. *Bti* application took place weekly. The monitoring of the sentinel sites was done 1–3 days after application. CG formulation was applied in week (wk) 1, 2 and 3, WDG formulation was applied from week 4. Differences in immature densities were analysed using Mann-Whitney tests at a significance level of  $p < 0.05$ . Different letters (a, b) on bars indicate a significant difference at the specific sampling date.

Environmentally safe microbial larvicides could be an additional tool in an IVM programme in The Gambia but due to the lack of residual effect of the microbial larvicides, there is a need to assess the costs of weekly applications in consideration of reduction in transmission intensity.

**Authors' contributions**

UF, SWL and SM designed the study. SM was responsible for the implementation of the study in the laboratory and the field. CG carried out the species identification of members of the *An. gambiae* complex. BK assisted with the organization of the field trial. UF and SM analysed the data. All authors were involved in the manuscript writing, read and approved the final manuscript.

**Acknowledgements**

We are grateful to the helpful suggestions made by two anonymous referees. We wish to thank the local community

of Tamba Koto for allowing us to treat and sample in their rice fields.

We are grateful to Malick Saïdy, Sara Bah, Boukary Loum, Mam Sering Secka and Modi Ceesay for allowing us to use their pictures for this publication. We thank David Conway and the staff of the Medical Research Council (MRC) Laboratories for their support and the National Malaria Control Programme staff who participated in this study. We are also grateful to Peter DeChant, Steven Krause and Robert Fusco from Valent BioSciences Corp. (VBC) for their technical support. This study was funded by the National Institute of Health (NIH) Grant No. 1 UO1 AI058250-01. The microbial larvicides were donated by VBC. UF was supported by the Environmental Health

Project (EHP) of the United States Agency of International Development (USAID).

### References:

- Coleman M, Sharp B, Seocharan I, Hemingway J: Developing an evidence-based decision support system for rational insecticide choice in the control of African malaria vectors. *J Med Entomol* 2006, 43(4):663-668.
- Winstanley PA, Ward SA, Snow RW: Clinical status and implications of antimalarial drug resistance. *Microbes Infect* 2002, 4(2):157-164.
- Chen H, Fillinger U, Yan G: Oviposition behavior of female *Anopheles gambiae* in western Kenya inferred from microsatellite markers. *Am J Trop Med Hyg* 2006, 75(2):246-250.
- Fillinger U, Lindsay SW: Suppression of exposure to malaria vectors by an order of magnitude using microbial larvicides in rural Kenya. *Trop Med Int Health* 2006, 11(11):1629-1642.
- Fillinger U, Sonye G, Killeen GF, Knols BG, Becker N: The practical importance of permanent and semipermanent habitats for controlling aquatic stages of *Anopheles gambiae* sensu lato mosquitoes: operational observations from a rural town in western Kenya. *Trop Med Int Health* 2004, 9(12):1274-1289.
- Gu W, Novak RJ: Habitat-based modeling of impacts of mosquito larval interventions on entomological inoculation rates, incidence, and prevalence of malaria. *Am J Trop Med Hyg* 2005, 73(3):546-552.
- Killeen GF, Fillinger U, Kiche I, Gouagna LC, Knols BG: Eradication of *Anopheles gambiae* from Brazil: lessons for malaria control in Africa? *Lancet Infect Dis* 2002, 2(10):618-627.
- Mutuku FM, Bayoh MN, Gimnig JE, Vulule JM, Kamau L, Walker ED, Kabiru E, Hawley WA: Pupal habitat productivity of *Anopheles gambiae* complex mosquitoes in a rural village in western Kenya. *Am J Trop Med Hyg* 2006, 74(1):54-61.
- Shililu JI, Tewolde GM, Brantly E, Githure JI, Mbogo CM, Beier JC, Fusco R, Novak RJ: Efficacy of *Bacillus thuringiensis israelensis*, *Bacillus sphaericus* and temephos for managing *Anopheles* larvae in Eritrea. *J Am Mosq Control Assoc* 2003, 19(3):251-258.
- Vanek MJ, Shoo B, Mtasiwa D, Kiama M, Lindsay SW, Fillinger U, Kan-nady K, Tanner M, Killeen GF: Community-based surveillance of malaria vector larval habitats: a baseline study in urban Dar es Salaam, Tanzania. *BMC public health [electronic resource]* 2006, 6:154.
- Yohannes M, Haile M, Ghebreyesus TA, Witten KH, Getachew A, Byass P, Lindsay SW: Can source reduction of mosquito larval habitat reduce malaria transmission in Tigray, Ethiopia? *Trop Med Int Health* 2005, 10(12):1274-1285.
- WHO: Guidelines for integrated vector management. Harare, WHO Regional Office for Africa; 2003.
- Fillinger U, Knols BG, Becker N: Efficacy and efficiency of new *Bacillus thuringiensis* var *israelensis* and *Bacillus sphaericus* formulations against Afrotropical anophelines in Western Kenya. *Trop Med Int Health* 2003, 8(1):37-47.
- WHO: International programme on chemical safety (IPCS): Microbial pest control agent *Bacillus thuringiensis*. *Environmental Health Criteria* 1999, 217:1-105.
- Mulla MS, Thavara U, Tawatsin A, Chomposri J, Su T: Emergence of resistance and resistance management in field populations of tropical *Culex quinquefasciatus* to the microbial control agent *Bacillus sphaericus*. *J Am Mosq Control Assoc* 2003, 19(1):39-46.
- Mukabana WR, Kannady K, Ijumba J, Mathenge E, Kiche I, Nkwengulila G, Mboera L, Mtasiwa D, Yamagata Y, van Schayk I, Knols BG, Lindsay SW, Caldas de Castro M, Mshinda H, Tanner M, Fillinger U, Killeen GF: Ecologists can enable communities to implement malaria vector control in Africa. *Malar J* 2006, 5(1):9.
- NMCP: National Malaria Control Strategic Plan 2002-2007. Gambia Department of State for Health and Welfare; 2002.
- Hougard JM, Mbentengam R, Lochouart L, Escaffre H, Darriet F, Bar-bazan P, Quillevere D: Campaign against *Culex quinquefasciatus* using *Bacillus sphaericus*: results of a pilot project in a large urban area of equatorial Africa. *Bull World Health Organ* 1993, 71(3-4):367-375.
- Karch S, Asidi N, Manzambi ZM, Salaun JJ: Efficacy of *Bacillus sphaericus* against the malaria vector *Anopheles gambiae* and other mosquitoes in swamps and rice fields in Zaire. *J Am Mosq Control Assoc* 1992, 8(4):376-380.
- Karch S, Manzambi ZA, Salaun JJ: Field trials with Vectolex (*Bacillus sphaericus*) and Vectobac (*Bacillus thuringiensis* (H-14)) against *Anopheles gambiae* and *Culex quinquefasciatus* breeding in Zaire. *J Am Mosq Control Assoc* 1991, 7(2):176-179.
- Nicolas L, Darriet F, Hougard JM: Efficacy of *Bacillus sphaericus* 2362 against larvae of *Anopheles gambiae* under laboratory and field conditions in West Africa. *Med Vet Entomol* 1987, 1(2):157-162.
- Ravoahangimalala O, Thiery I, Sinegre G: Rice field efficacy of deltamethrin and *Bacillus thuringiensis israelensis* formulations on *Anopheles gambiae* s.s. in the Anjiro Region of Madagascar. *Bulletin of the Society of Vector Ecology* 1994, 19(2):169-174.

23. Bogh C, Clarke SE, Jawara M, Thomas CJ, Lindsay SW: Localized breeding of the *Anopheles gambiae* complex (Diptera: Culicidae) along the River Gambia, West Africa. *Bull Entomol Res* 2003, 93(4):279-287.
24. Thomas CJ, Lindsay SW: Local-scale variation in malaria infection amongst rural Gambian children estimated by satellite remote sensing. *Trans R Soc Trop Med Hyg* 2000, 94(2):159-163.
25. Lindsay SW, Alonso PL, Armstrong Schellenberg JR, Hemingway J, Thomas PJ, Shenton FC, Greenwood BM: A malaria control trial using insecticide-treated bed nets and targeted chemo-prophylaxis in a rural area of The Gambia, West Africa. 3. Entomological characteristics of the study area. *Trans R Soc Trop Med Hyg* 1993, 87 Suppl 2:19-23.
26. Koenraadt CJ, Githeko AK, Takken W: The effects of rainfall and evapotranspiration on the temporal dynamics of *Anopheles gambiae* s.s. and *Anopheles arabiensis* in a Kenyan village. *Acta Trop* 2004, 90(2):141-153.
27. Randomization tool [ <http://www.randomization.com> ]
28. Ragoonanansingh RN, Njunwa KJ, Curtis CF, Becker N: A field study of *Bacillus sphaericus* for the control of culicine and anopheline mosquito larvae in Tanzania. *Bulletin of the Society of Vector Ecology* 1992, 17(1):45-50.
29. Schnetter W, Engler S, Morawcik J, Becker N: Wirksamkeit von *Bacillus thuringiensis* var. israelensis gegen Stechmuecken und Non-Target Organismen. *Mitteilungen der Deutschen Gesellschaft fuer allgemeine und angewandte Entomologie* 1981, 2:195-202.
30. Scott JA, Brogdon WG, Collins FH: Identification of single specimens of the *Anopheles gambiae* complex by the polymerase chain reaction. *Am J Trop Med Hyg* 1993, 49(4):520-529.
31. WHO: Entomological field techniques for malaria control. *Volume Part I*. Geneva , World Health Organization; 1992:77.
32. Mulla MS, Norland RL, Fanara DM, Darwazeh A, McKean D: Control of chironomid midges in recreational lakes. *J Econ Entomol* 1971, 64(1):300-307.
33. Becker N, Rettich F: Protocol for the introduction of new *Bacillus thuringiensis* israelensis products into the routine mosquito control program in Germany. *J Am Mosq Control Assoc* 1994, 10:527-533.
34. Charles JF, Nielsen-LeRoux C: Mosquitocidal bacterial toxins: diversity, mode of action and resistance phenomena. *Mem Inst Oswaldo Cruz* 2000, 95(Suppl 1):201-206.
35. Seyoum A, Abate D: Larvicidal efficacy of *Bacillus thuringiensis* var. israelensis and *Bacillus sphaericus* on *Anopheles arabiensis* in Ethiopia. *World Journal of Microbiology & Biotechnology* 1997, 13:21-24.
36. Hougard JM: Formulation and persistence of *Bacillus sphaericus* in *Culex quinquefasciatus* larval sites in tropical Africa. In *Bacteriological Control of Mosquitoes and Blackflies* Edited by: de Barjac H, Gutherland DJ. New Brunswick , Rutgers University Press; 1990:295-306.
37. Lago GM, Perez MC, Figueroa AM, Sonzalez FAC: Results of a pilot application of the biolarvicide *Bacillus sphaericus* to larval habitats of mosquitoes in Santa Cruz del Norte municipality (La Habana Province). *Rev Cubana Med Trop* 1991, 43:39-44.
38. Mulla MS, Su T, Thavara U, Tawatsin A, Ngamsuk W, Pan-Urai P: Efficacy of new formulations of the microbial larvicide *Bacillus sphaericus* against polluted water mosquitoes in Thailand. *J Vector Ecol* 1999, 24(1):99-110.
39. Sutherland DD, McNelly JJ, Hansen JA: Evaluation of granular *Bacillus sphaericus* to control *Culex* in sewage treatment ponds in Cape May. *New Jersey Mosqu Contr Assoc* 1989, 76:84-90.
40. Karch S, Monteny N, Jullien JL, Sinagre G, Coz J: Control of *Culex pipiens* by *Bacillus sphaericus* and role of nontarget arthropods in its recycling. *J Am Mosq Control Assoc* 1990, 6(1):47-54.
41. Rojas JE, Mazzarri M, Sojo M, Garcia AG: Effectiveness of *Bacillus sphaericus* strain 2362 on larvae of *Anopheles nuneztovari*. *Invest Clin* 2001, 42(2):131-146.
42. Becker N, Zgomba M, Petric D, Beck M, Ludwig M: Role of larval cadavers in recycling processes of *Bacillus sphaericus*. *J Am Mosq Control Assoc* 1995, 11(3):329-334.
43. Charles JF, Nicolas L: Recycling of *Bacillus sphaericus* 2362 in mosquito larvae: a laboratory study. *Ann Inst Pasteur Microbiol* 1986, 137 B(1):101-111.
44. Skovmand O, Bauduin S: Efficacy of a granular formulation of *Bacillus sphaericus* against *Culex quinquefasciatus* and *Anopheles gambiae* in West African countries. *J Vector Ecol* 1997, 22(1):43-51.
45. Pantuwatana S, Sattabongkot J: Comparison of development of *Bacillus thuringiensis* subsp. israelensis and *Bacillus sphaericus* in mosquito larvae. *J Invertebr Pathol* 1990, 55(2):189-201.
46. Skovmand O, Sanogo E: Experimental formulations of *Bacillus sphaericus* and *B. thuringiensis israelensis* against *Culex quinquefasciatus* and *Anopheles gambiae* (Diptera: Culicidae) in Burkina Faso. *J Med Entomol* 1999, 36(1):62-67.

47. Robert V, Le Goff G, Arie F, Duchemin JB: A possible alternative method for collecting mosquito larvae in rice fields. *Malar J* 2002, 1:4.
48. Service MW: Studies on sampling larval populations of the *Anopheles gambiae* complex. *Bull World Health Organ* 1971, 45(2):169-180.
49. Zahiri NS, Su T, Mulla MS: Strategies for the management of resistance in mosquitoes to the microbial control agent *Bacillus sphaericus*. *J Med Entomol* 2002, 39(3):513-520.
50. Becker N, Ludwig M: Investigations on possible resistance in *Aedes vexans* field populations after a 10-year application of *Bacillus thuringiensis israelensis*. *J Am Mosq Control Assoc* 1993, 9(2):221-224.
51. Rozendaal JA: Vector Control - Methods for use by individuals and communities. Geneva , World Health Organization; 1997:411.
52. Pinkney AE, McGowan PC, Murphy DR, Lowe TP, Sparling DW, Ferrington LC: Effects of the mosquito larvicides temephos and methoprene on insect populations in experimental ponds. *Environmental Toxicology and Chemistry* 2000, 19:678-684.
53. U.S. Environmental Protection Agencies: Reregistration eligibility document for temephos [ [http://www.epa.gov/oppsrrd1/reregistration/REDS/temephos\\_red.htm](http://www.epa.gov/oppsrrd1/reregistration/REDS/temephos_red.htm) ]
54. Yapabandara AM, Curtis CF: Laboratory and field comparisons of pyriproxyfen, polystyrene beads and other larvicidal methods against malaria vectors in Sri Lanka. *Acta Trop* 2002, 81(3):211-223.
55. Yapabandara AM, Curtis CF: Control of vectors and incidence of malaria in an irrigated settlement scheme in Sri Lanka by using the insect growth regulator pyriproxyfen. *J Am Mosq Control Assoc* 2004, 20(4):395-400.
56. Yapabandara AM, Curtis CF, Wickramasinghe MB, Fernando WP: Control of malaria vectors with the insect growth regulator pyriproxyfen in a gem-mining area in Sri Lanka. *Acta Trop* 2001, 80(3):265-276.
57. Seng CM, Setha T, Chanta N, Socheat D, Guillet P, Nathan MB: Inhibition of adult emergence of *Aedes aegypti* in simulated domestic water-storage containers by using a controlled-release formulation of pyriproxyfen. *J Am Mosq Control Assoc* 2006, 22(1):152-154.

## PREDICTORS OF DISEASE PROGRESSION IN HIV INFECTION: A REVIEW

Langford S. E.<sup>1,2</sup>, Ananworanich J.<sup>2</sup>, Cooper D. A.<sup>2,3</sup>

<sup>1</sup>Monash University, Melbourne, Australia,

<sup>2</sup>The HIV Netherlands Australia Thailand Research Collaboration, Bangkok, Thailand

<sup>3</sup>The National Centre in HIV Epidemiology and Clinical Research, Sydney, Australia, University of New South Wales, Sydney, Australia

---

During the extended clinically latent period associated with Human Immunodeficiency Virus (HIV) infection the virus itself is far from latent. This phase of infection generally comes to an end with the development of symptomatic illness. Understanding the factors affecting disease progression can aid treatment commencement and therapeutic monitoring decisions. An example of this is the clear utility of CD4+ T-cell count and HIV-RNA for disease stage and progression assessment. Elements of the immune response such as the diversity of HIV-specific cytotoxic lymphocyte responses and cell-surface CD38 expression correlate significantly with the control of viral replication. However, the relationship between soluble markers of immune activation and disease progression remains inconclusive. In patients on treatment, sustained virological rebound to >10 000 copies/mL is associated with poor clinical outcome. However, the same is not true of transient elevations of HIV RNA (blips). Another virological factor, drug resistance, is becoming a growing problem around the globe and monitoring must play a part in the surveillance and control of the epidemic worldwide. The links between chemokine receptor tropism and rate of disease progression remain uncertain and the clinical utility of monitoring viral strain is yet to be determined. The large number of confounding factors has made investigation of the roles of race and viral subtype difficult, and further research is needed to elucidate their significance. Host factors such as age, HLA and CYP polymorphisms and psychosocial factors remain important, though often unalterable, predictors of disease progression. Although gender and mode of transmission have a lesser role in disease progression, they may impact other markers such as viral load. Finally, readily measurable markers of disease such as total lymphocyte count, haemoglobin, body mass index and delayed type hypersensitivity may come into favour as ART becomes increasingly available in resource-limited parts of the world. The influence of these, and other factors, on the clinical progression of HIV infection are reviewed in detail, both preceding and following treatment initiation.

---

### Review

Throughout the clinically latent period associated with Human Immunodeficiency Virus (HIV) infection the virus continues to actively replicate, usually resulting in symptomatic illness [1-3]. Highly variable disease progression rates between individuals are well-recognised, with progression categorised as rapid, typical or intermediate and late or long-term non-progression [1,4]. The majority of infected individuals (70–80%) experience intermediate disease progression in which they have HIVRNA rise, CD4+ T-cell decline and development of AIDS-related

illnesses within 6–10 years of acquiring HIV. Ten to 15% are rapid progressors who have a fast CD4+ T-cell decline and occurrence of AIDS-related events within a few years after infection. The late progressors (5%), can remain healthy without significant changes in CD4 count or HIV-RNA for over 10 years [4].

While Figure 1[5] demonstrates the existence of a relationship between high plasma HIV-RNA, low peripheral CD4+ T-cell count and rapidity of disease progression, many of the determinants of this variation in progression are only partially understood. Knowledge of prognostic

determinants is important to guide patient management and treatment. Much research has focussed on many different facets of HIV pathogenesis and possible predictive factors, covering immunological, virological and host genetic aspects of disease. Current therapeutic guidelines take many of these into account but their individual significance warrants review [6].

Immunological factors

*T-cell count and function*

*CD4+ T-cells*

CD4+ T-cells are fundamental to the development of specific immune responses to infection, particularly intracellular pathogens. As the primary target of HIV, their depletion severely limits the host response capacity. HIV largely infects activated cells, causing the activated T-cells directed against the virus to be at greatest risk of infection [7]. The ability of the immune system to mount a specific response against HIV is a key factor in the subsequent disease course [8]. Long-term non-progressors appear to have better lymphoproliferative responses to HIV-specific antigens than those with more rapid progression [8].

The CD4+ T-cell count is the most significant predictor of disease progression and survival [9-15], and the US Department of Health and Human Services (DHHS) ART treatment guidelines recommends treatment commencement be based on CD4+ T-cell count in preference to any other single marker [6]. Table 1 shows the results of the CASCADE collaboration<sup>i</sup> (see Appendix 1 for details) analysis of an international cohort of 3226 ART-naïve individuals with estimable dates of seroconversion. Each CD4 count was considered to hold predictive value for no more than the subsequent 6 month period, with individual patients contributing multiple 6 month periods of follow up [10]. Lower CD4 counts are associated with greater risk of disease progression. CD4 counts from 350–500 cells/mm<sup>3</sup> are associated with risks of ≤5% across all age and HIV-RNA strata,

while the risk of progression to AIDS increases substantially at CD4 counts <350 cells/mm<sup>3</sup>, the greatest risk increase occurring as CD4 counts fall below 200 cells/mm<sup>3</sup>. The risk of disease progression at 200 cells/mm<sup>3</sup>, the threshold for ART initiation in resource-limited settings, is generally double the risk at 350 cells/mm<sup>3</sup>, the treatment threshold in resource-rich countries [10].

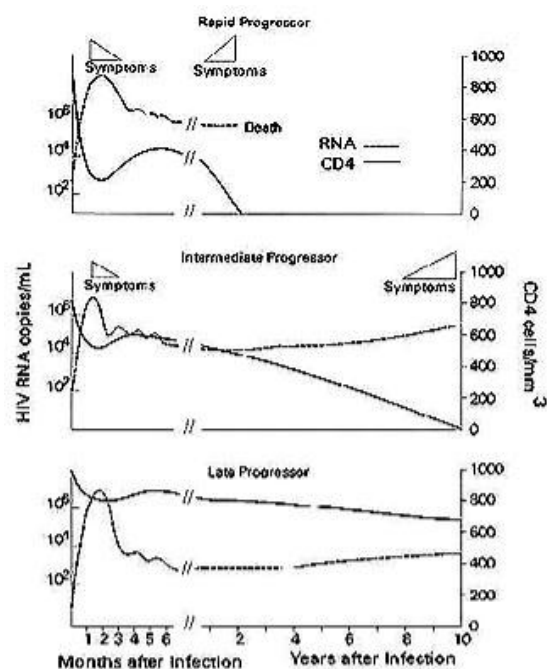

**Figure 1.** General pattern of the natural history of HIV-RNA levels and CD4 counts at three rates of disease progression [5] (Reproduced from Figure 1, HIV InSite Knowledge Base, with permission).

Use of the CD4 count as a means of monitoring ART efficacy is well established [6,16]. In particular, measurement of the early response in the first six months of therapy has strong predictive value for future immunological progression [17, 18]. Baseline CD4 count is predictive of virological failure, Van Leth et al. [19] finding a statistically significant correlation between a baseline CD4 count of <200 cell/mm<sup>3</sup> and HIV-RNA >50 copies/mL at week 48 of therapy. Figure 2 shows the importance of

baseline CD4 count as a predictor of disease progression; each stratum of CD4 count <200 cell/mm<sup>3</sup> at time of HAART initiation being associated with an increasingly worse prognosis [ 20 ]. Immunological recovery is

largely dependent on baseline CD4 count and thus the timing of ART initiation is important in order to maximise the CD4+ T-cell response to therapy [20 ].

**Table 1.** Predicted 6 month risk of AIDS according to age, current CD4+ cell count and viral load, based on a Poisson regression model

Viral load (copies/mL)			Predicted risk (%) at current CD4 count (× 106 cells/L)							
	50	100	150	200	250	300	350	400	450	500
<b>25 years</b>										
3000	6.8	3.7	2.3	1.6	1.1	0.8	0.6	0.5	0.4	0.3
10 000	9.6	5.3	3.4	2.3	1.6	1.2	0.9	0.7	0.5	0.4
30 000	13.3	7.4	4.7	3.2	2.2	1.6	1.2	0.9	0.7	0.6
100 000	18.6	10.6	6.7	4.6	3.2	2.4	1.8	1.4	1.1	0.8
300 000	25.1	14.5	9.3	6.3	4.5	3.3	2.5	1.9	1.5	1.2
<b>35 years</b>										
3000	8.5	4.7	3.0	2.0	1.4	1.0	0.8	0.6	0.5	0.4
10 000	12.1	6.7	4.3	2.9	2.0	1.5	1.1	0.9	0.7	0.5
30 000	16.6	9.3	5.9	4.0	2.8	2.1	1.6	1.2	0.9	0.7
100 000	23.1	13.2	8.5	5.8	4.1	3.0	2.3	1.7	1.3	1.1
300 000	30.8	18.0	11.7	8.0	5.7	4.2	3.1	2.4	1.9	1.5
<b>45 years</b>										
3000	10.7	5.9	3.7	2.5	1.8	1.3	1.0	0.7	0.6	0.5
10 000	15.1	8.5	5.4	3.6	2.6	1.9	1.4	1.1	0.8	0.7
30 000	20.6	11.7	7.5	5.1	3.6	2.6	2.0	1.5	1.2	0.9
100 000	28.4	16.5	10.6	7.3	5.2	3.8	2.9	2.2	1.7	1.3
300 000	37.4	22.4	14.6	10.1	7.2	5.3	4.0	3.1	2.4	1.9
<b>55 years</b>										
3000	13.4	7.5	4.7	3.2	2.3	1.7	1.2	0.9	0.7	0.6
10 000	18.8	10.7	6.8	4.6	3.3	2.4	1.8	1.4	1.1	0.8
30 000	25.4	14.6	9.4	6.4	4.6	3.3	2.5	1.9	1.5	1.2
100 000	34.6	20.5	13.3	9.2	6.5	4.8	3.6	2.8	2.2	1.7
300 000	44.8	27.5	18.2	12.6	9.1	6.7	5.0	3.9	3.0	2.4

<2%, risk 2–9.9%, risk 10–19.9%, risk ≥20%

This table is reproduced from Table 4 in [10]

It is important to note that within-patient variability in CD4+ T-cell quantification can occur and so care must be taken to ensure measurements are consistently performed by the same method for each patient [9].

#### *CD8 T-lymphocyte function*

The influence of CD8+ T-lymphocyte function on HIV disease progression is of considerable interest as cytotoxic T-lymphocytes (CTLs) are the main effector cells of the specific cellular immune response. Activated by CD4+ T-helper cells, anti-HIV specific CD8+ T-cells have a crucial role to play in the control of viremia [21], increasing in response to ongoing viral replication [22]. Further, the diversity of HIV-specific CTL responses correlates with the control of viral replication and CD4 count, indicating the need for a response to a broad range of antigens to achieve a maximum effect [ 23 , 24]. Low absolute numbers of HIV- specific CD8+ T-cells correlate with poor survival outcomes in both ART-naïve and experienced patients, providing additional evidence for the significance of the CTL response [ 23, 25 , 26].

#### *Immune activation*

Chronic immune activation is a characteristic of HIV disease progression. Immune-activation-driven apoptosis of CD4+ cells, more than a direct virological pathogenic effect, is responsible for the decline in CD4+ T-lymphocytes seen in HIV infection [27]. HIV triggers polyclonal B cell activation, increased T cell turnover, production of proinflammatory cytokines and increased numbers of activated T cells [28]. CD4+ T cells that express activation markers such as CD69, CD25, and MHC class II are a prime target for HIV infection and a source of active HIV replication. Increased numbers of these activated T cells correlate with HIV disease progression [29-31]. Another important surface marker of cell activation is CD38. In HIV negative individuals, CD38 is expressed in relatively greater numbers by

naïve lymphocytes, while in HIV infection, memory T-cells, particularly CD8+ memory T-cells, express the largest quantities of CD38 [ 32, 33 ]. CD8+CD38+T-cell levels correlate strongly with HIV-RNA levels, decreasing with ART-induced virological suppression and increasing with transient viremia, suggesting that continuously high levels of CD38+ cells may be an indicator of ongoing viral replication [32-35]. Indeed, HIV replication has been nominated the main driving force behind CD8+ T-cell activation [32 , 33]. Similar to the stabilization of HIV-RNA levels following initial infection, an immune activation "set point" has also been described and shown to have prognostic value [36].

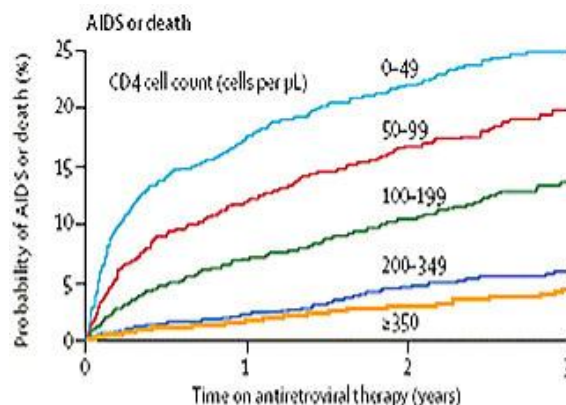

**Figure 2.** Kaplan Meier plots of the probability of progression to AIDS or death according to baseline CD4 count [20] (reproduced with permission).

Despite the strength of the relationship with HIV-RNA, the search for a clear association between CD8+ T-cell activation and CD4 count has resulted in conflicting findings [ 32 , 33 , 35 , 37 ]. In contrast, CD4+ T-cell activation has a considerable influence on CD4+ T-cell decline [27,34,35]. One prospective study of 102 seroconverters has found that CD8+CD38+ proportions lose their prognostic significance over time and only elevated CD4+CD38+ percentage is associated with clinical deterioration at 5



years follow up [ 27]. The clinical value of monitoring CD38 expression is yet to be clarified, however, there is no doubt that disease progression is related to both CD4+ and CD8+ T-cell activation as indicated by expression of CD38.

A switch from T-Helper Type 1 (TH1) to T-Helper Type 2 (TH2) cytokine response is seen in HIV-related immune dysfunction and is associated with HIV disease progression. TH1 cytokines such as interleukin (IL)-2, IL-12, IL18 and interferon- $\gamma$  promote strong cellular responses and early HIV viremic control while TH2 cytokines, predominantly modulated by IL-1 $\beta$ , IL-4, IL-6, IL-10 and tumor necrosis factor- $\alpha$  (TNF- $\alpha$ ), promote HIV viral replication and dampen cellular response to HIV [8, 38 ]. HIV-positive individuals have high plasma IL-10 levels, reduced production of IL-12 and poor proliferation of IL-2 producing CD4+ central memory T-cells [30,39,40]. Levels of pro-inflammatory cytokines such as TNF- $\alpha$  are also increased, causing CD8+ T-cell apoptosis [1,40].

Soluble markers of immunological activity have been the focus of many studies over the years in the hope that they will show utility as prognostic indicators. Unfortunately, the product of these endeavours is a large number of studies with apparently conflicting results, some studies linking elevated levels of these markers with more rapid disease progression [41-46], and others finding no correlation [ 46 -48 ]. Factors investigated include neopterin [41 43, 45 , 46, 48 ],  $\beta_2$ -microglobulin [42 , 46-48], tumour necrosis factor type II receptor [41,46], tumour necrosis factor receptor 75 [45], endogenous interferon [43] and tumour necrosis factor- $\alpha$  [25]. The lack of specificity of these markers for HIV infection appears to curtail their utility. Current treatment guidelines make no mention of their use for either disease or therapeutic monitoring [ 6, 49 , 50]. As the immune response to HIV is clarified with further research, the utility of

monitoring these immune modulators may become more apparent.

#### Virological factors

##### *HIV-RNA*

The value of HIV-RNA quantification as a prognostic marker has long been established [6,51,52]. An approximately inverse relationship to the CD4+ T-cell count and survival time has been observed in around 80% of patients [53,54]. Higher HIV-RNA levels are associated with more rapid decline of CD4+ T-cells, assisting prediction of the rate of CD4 count decline and disease progression. However, once the CD4 count is very low (<50–100 cells/mm<sup>3</sup>), the disease progression risk is so great that HIV-RNA levels add little prognostic information [25,54 56]. The correlation between CD4 count and disease progression seen clearly in Table 1 has already been described [ 10 ]. Further highlighting the risk of AIDS in those with CD4 counts of 200–350 cell/mm<sup>3</sup> (the current threshold for ART initiation), a four-fold risk increase can be seen between those with a HIV-RNA of 3000 copies/mL and those with  $\geq 300\ 000$  copies/mL, even within the same age bracket. Additionally, there is a considerable increase in risk of disease progression in those with HIV-RNA >100 000 copies/mL across all age and CD4 strata.

Higher baseline HIV-RNA levels in early infection have been associated with faster CD4+ T-cell decline over the first two years of infection [15 , 57]. Research has suggested that HIV-RNA levels at later time points are better indicators of long term disease progression than levels at seroconversion, with the viral load reaching a stable mean or 'set point' around one year after infection [4,12,52,58,59]. Indicative of the efficiency of immunological control of viral replication, this set point is strongly associated with the rate of disease progression as can be inferred from Figure 1 [ 1 , 52, 59 - 62 ]. Desquilbet et al. [63] studied the effect of early ART on the virological set point by starting treatment

during Primary HIV Infection (PHI) and then ceasing it soon after. They found the virological set point was mainly determined by pre-treatment viral load, early treatment having minimal reducing effect.

Treatment response has been strongly linked to the base line HIV-RNA level; Van Leth et al. [19] finding that patients with a HIV-RNA >100 000 copies/mL were almost 1.5 times more likely to experience virological failure (HIV-RNA >50 copies/mL) after 48 weeks of treatment than those with HIV-RNA <100 000 copies/mL.

An analysis of a subgroup (6814 participants) of the EuroSIDA study cohort verified that clinical outcome correlates strongly with most recent CD4+ T-cell or HIV RNA level, regardless of ART regimen used. In particular, it is worth noting that those with CD4 count  $\leq 350$  cells/mm<sup>3</sup> were at increased risk of AIDS or death than higher CD4 counts (rate ratio  $\geq 3.39$  vs  $\leq 1.57$ ), while the risk of these outcomes was substantially lower at HIV-RNA <500 copies/mL compared to >50 000 copies/mL (rate ratio 0.22 vs 0.61) [64]. These findings support the continued use of HIV-RNA and CD4 count as markers of disease progression on any HAART regimen [6,51,65].

There is no doubt that monitoring viral load is critical to assessing the efficacy of ART [65 -68]. Findings from multiple studies reinforce the association between greater virological suppression and sustained virological response to ART [6,50]. Guidelines define virological failure as either a failure to achieve an undetectable HIV-RNA (<50 copies/mL) after 6 months or a sustained HIV-RNA >50 copies/mL or >400 copies/mL following suppression below this level [6]. A greater than threefold increase in viral load has been associated with increased risk of clinical deterioration and so this value is recommended to guide therapeutic regimen change in the developed world [69, 70]. Several studies have shown a significant correlation between HIV-RNA >10 000 copies/mL and increased mortality

and morbidity, and therapeutic switching should occur prior to this point [49]. The World Health Organisation recommends that this level be considered the definition of virological failure in resource limited settings [49].

Some patients experience intermittent episodes of low-level viremia followed by re-suppression below detectable levels, known as "blips". A very detailed study by Nettles et al. [71] defined a typical blip as lasting about 2.5 days, of low magnitude (79 copies/ml) and requiring no change in therapy to return to <50 copies/ml. Havlir et al. [72] and Martinez et al. [73] demonstrated that there was no association between intermittent low-level viremia and virological failure. Intermittent viremia does not appear to be a significant risk factor for disease progression. Nevertheless, it must be distinguished from true virological failure, which is consistently elevated HIVRNA, as defined above. Continued follow up is essential.

Even in patients achieving apparently undetectable HIVRNA levels, the HIV virus persists through the infection of memory T-cells [74, 75]. This 'viral reservoir' has an extremely long half life and remains remarkably stable even in prolonged virological suppression [74, 76, 77]. Responsible for the failure of ART to eradicate infection, regardless of therapy efficacy, it may also contribute to the 'blips' described above [76]. Like intermittent viremia, its effect on disease progression appears trivial, being mainly of therapeutic importance [78, 79]. However, as the long-term clinical outcomes of viral resistance and sub-detection viral replication become clearer, its significance may increase [15].

#### Resistance mutations

Drug resistance is a strong predictor of virological failure after HAART, with a clear relationship seen between the number of mutations and virological outcome [56,80-84]. Hence maximal suppression of viral replication, with the parallel effect of preventing the development of resistance, is

essential to optimise both response to treatment and improvement in disease progression [ 85, 86 ].

The transmission of resistant virus is a serious reality, with implications for the efficacy of initial regimens in ART naïve patients. Prevalence of resistance mutations amongst seroconverters varies according to geographic location, with inter-country prevalence varying from 3– 26%. This reinforces the need to gain local data, especially as resistance increases with increasing HAART use [ 87]. In the USA, the prevalence of primary (transmitted) resistance was 24.1% in 2003–2004, an almost two-fold increase from the 13.2% prevalence recorded in 1995– 1998 [88 ]. European prevalence for 2001–2002 was 10.4%, which, although lower than the US figures, remains quite high [86,87]. Pre-treatment resistance testing has been shown to reduce the risk of virological failure in patients with primary drug resistance [6,50]. The DHHS guidelines suggest that pre-treatment resistance testing in ART naïve patients may be considered if the risk of resistance is high (ie: population prevalence  $\geq 5\%$ ) while the British HIV Association (BHIVA) recommends testing for transmitted resistance in all newly diagnosed patients and prior to initiating ART in chronically infected patients [ 49 ]. In resource-limited settings, resistance testing may not be readily available; however, in such locations, primary resistance is likely to be rare, and need for pre-treatment resistance testing is lower [89]. An exception to this rule is the case of child-bearing women who have received intrapartum nevirapine, in whom poorer virological responses to post-partum nevirapine based regimens have been seen (49% vs 68% achieved HIV-RNA  $< 50$  copies/ mL at 6 months) [49,89]. Regardless of the setting, there is a need for surveillance of local drug resistance prevalence [ 1 , 2 , 90].

#### Chemokine receptor tropism

CCR5 and CXCR4 chemokine receptors act as co-receptors for HIV virions. Proportionately greater tropism for one or the other of these receptors has been associated with different rates of disease progression. Slowly progressing phases of infection are associated with predominance of the "R5 virus strains" that ligate the CCR5 receptor, mainly present on activated immune cell surfaces (including macrophages). "X4 strains" showing tropism for CXCR4, expressed by naïve or resting T-cells, and dual-tropic R5X4 strains, increase proportionately in the later stages of disease and are associated with more rapid clinical and immunological deterioration [1,2,90]. 'X4' strains have been associated with greater immune activation, suggesting a possible mechanism for their effects on disease progression [27]. Patients with predominantly X4 strains have been found to have lower CD4 counts, but correlations with viral load have been inconsistent [90 -92 ]. Some host genetic phenotypes namely CCR5- $\Delta 32$  and SDF-1'A, affect R5 strain binding and are associated with delayed disease progression [93 -95 ].

It is evident that even under effective HAART suppression [ 96 ], the predominant viral strain can change from R5 to X4 [90,92,97]. Additionally, about 50% of triple therapy experienced patients have been found to harbour X4 strains, a far greater proportion than the 18.2% seen in an ART naïve population [98]. The evidence for a difference in survival between those on HAART with X4 strains and those with R5 strains is difficult to interpret. Brumme et al. [ 98 ] suggested that a group of patients with the 11/25 envelope sequence (a highly specific predictor of the presence of X4 strains) had higher mortality and poorer immunological response to HAART despite similar virological responses to those without the 11/25 sequence. In contrast, a later study indicated that after adjustment for baseline characteristics, X4 strains were not

associated with a difference in survival or response to HAART [99]. As can be seen, the effects of chemokine receptor tropism remain controversial and as yet, there is no clear evidence that monitoring or measuring these parameters will be useful clinically.

#### Viral subtype and race

Complicating the assessment of the effect of viral subtype on disease progression are the potential confounders such as race, prevalence of various opportunistic infections and access to health care. Subtype C affects 50% of people with HIV and is seen mostly in Southern and Eastern Africa, India and China. Subtype D is found in East Africa and Subtype CRF\_01\_AE is seen mainly in Thailand. Caucasians are predominantly infected by subtype B, seen in 12% of the global HIV infected population [99]. The majority of research on all aspects of HIV has been performed amongst subtype B-affected individuals. The implications for treatment practice are obvious should differences in viral pathogenicity or disease progression exist between subtypes [99, 100].

Rangsin et al. [100] noted median survival times in young Thai men (Type E 97%) of only 7.4 years, significantly shorter than the 11.0 years reported by the mainly Caucasian CASCADE cohort (Type B  $\geq$  50%). Hu et al. [101] found differences in early viral load between those with Type E ( $n = 103$ ) when compared to Type B ( $n = 27$ ) in Thai injecting drug users. Kaleebu et al. [102] studied a large cohort in Uganda, providing the strongest evidence for a difference in survival between A and D subtypes. However, analysis of a small cohort in Sweden reported no difference in survival rates between subtypes A-D [103]. Only Rangsin et al. [100] and Hu et al. [101] studied cohorts with estimable seroconversion dates.

It is difficult to control for the multiple potential confounding factors in research measuring the influence of subtype on disease progression. Geretti [99] remarked

that the evidence for survival and disease progression rate differences between subtypes is currently inadequate to draw any definitive conclusions. Ongoing research is essential not only to determine the effect of subtype on disease progression but also to evaluate response to therapy.

Many of the confounding factors affecting subtype investigation also confound research into the effect of race on disease progression. Studies with clinical endpoints have found no significant relationship between race and disease progression [104, 105], while another study of clinical response to HAART suggested disease progression appears to correlate more strongly with other factors (eg: depression, drug toxicity) than with race per se [106]. In support of this, data from the TAHOD database<sup>ii</sup> (see Appendix 1 for details) suggests that responses to HAART among Asians are comparable to those seen in other races [11]. Evidence for racial variation in viral loads and CD4 counts has not been consistent and confounders have been difficult to exclude [107-109]. Morgan et al. [110] reported a median survival time of 9.8 years amongst HIV infected Ugandans which does not differ greatly from the 11.0 years reported by the mainly Caucasian CASCADE cohort. Race as an independent factor does not appear to play a part in the rate of disease progression independently of confounders such as psychosocial factors, access to care and genetically driven response to therapy.

#### Host genetics

An understanding of the effect of host genetics on disease susceptibility and progression has significant implications for the development of therapies and vaccines [95]. Host genetics impact HIV infection at two main points: (i) cell-virion fusion, mediated primarily by the chemokine receptors CXCR4 and CCR5 and their natural ligands, and (ii) the host immune response, mediated by Human Leukocyte Antigen (HLA) molecules [95, 111].

Polymorphisms of the genes controlling these two pathways have been extensively studied and multiple genetic alleles that have been found to correlate with either delayed or accelerated disease progression [95,111,112].

HLA molecules provide the mechanism by which the immune system generates a specific response to a pathogen. As has been described earlier, the diversity of HIV-specific immune responses plays a crucial role in containment of the virus and it is HLA molecules that control that diversity. Thus, HLA polymorphisms should affect disease progression. Investigation of the effect of specific alleles has found that heterozygosity of any MHC Class I HLA alleles appears to delay progression, while rapid progression has been associated with some alleles in particular, for example, HLA-B35 and Cw4 [95]. The HLA-B57 allele, present in 11% of the US population and around 10% of HIV-positive individuals, has been linked to long-term non-progression, a lower viral set-point and fewer symptoms of primary HIV infection [95,112].

In addition to the effect of genetic polymorphisms on the natural history of infection, host genetic profile can influence the response to HAART [113]. In Australia, the presence of the HLA-B5701 allele accounts for nearly 90% of patients with abacavir hypersensitivity. Drug clearance also varies significantly between racial groups due to genetic variations in CYP enzyme isoforms [114]. For example, polymorphisms of CYP2B6 occurring more frequently in people of African origin are associated with three-fold greater plasma efavirenz concentrations, leading to a greater incidence of central nervous system toxicity amongst this group [115]. Potential outcomes of such phenomena include treatment discontinuation in the case of toxicity or hypersensitivity and drug resistance when medications are ceased simultaneously causing mono-therapy of the drug with the prolonged half life [114]. Genetic screening

in order to guide choice of therapy is already underway in Australia for HLA-B57 alleles related to abacavir hypersensitivity [114]. Studies of host genetics appear likely to significantly influence the clinical management of HIV in the future.

#### Other host factors

Studies of many of these factors usually assume equality of access to care for members of the study population. A survey of people living with AIDS in New York city found that female gender, older age, non-Caucasian race and transmission via injecting drug use or heterosexual intercourse were all associated with significantly higher mortality. This most likely reflects the poorer access to health care and other sociological disparities experienced by these groups [116].

#### Age

Age at seroconversion has repeatedly been found to have considerable impact on the future progression of disease. Concurring with earlier studies, the CASCADE collaboration [62] found a considerable age effect correlating with CD4 count and HIV-RNA, across all exposure categories, CD4 count and HIV-RNA strata in an analysis of multiple international seroconversion cohorts, reinforcing these findings again recently [10,117,118]. Table 1 clearly demonstrates the importance of stratification by age, CD4 count and HIV-RNA as predictive of the short term risk of AIDS. There is a clear relationship between increasing risk with increasing age. For example, a 25 year old with a CD4 count of 200 and HIV-RNA level of 3000 has one third the risk of disease progression when compared to a 55 year old. This raises the issue of whether or not older patients should be treated at higher CD4+ T-cell counts [10].

Older age is associated with lower CD4 counts at similar time from seroconversion which may explain the relationship between age and disease progression [57,119]. However, age disparities seem to diminish with HAART treatment; CD4 counts and HIV-

RNA levels becoming more useful prognostic indicators [119]. It appears that the age effect seen on HAART treatment is closer to the natural effect of aging rather than the pre-treatment, HIV-related increase in mortality, suggesting that HAART attenuates the effect of age at seroconversion on HIV disease progression [120].

#### Gender

Mean HIV-RNA has been found to vary between men and women for given CD4 count strata [107,121-123]. Low levels of CD4+ T-cells ( $<50$  cells/mm<sup>3</sup>) are associated with higher mean HIV-RNA in women (of the order of  $1.3 \log_{10}$  copies/mL) than in men within the same CD4 count stratum. Conversely, at higher CD4+ T-cell levels ( $>350$  cells/mm<sup>3</sup>), mean HIV-RNA has been noted to be  $0.2-0.5 \log_{10}$  copies/mL lower in women [124]. Despite HIV-RNA variation, disease progression has not been seen to differ between the genders for given CD4 counts [121,124,125]. On this basis, the current DHHS *Guidelines for the use of Antiretroviral Drugs in HIV-1 Infected Adults and Adolescents* state that there is no need for sex-specific treatment guidelines for the initiation of treatment given that antiretroviral therapy initiation is guided primarily by CD4 count [6].

#### Mode of transmission

Comparing disease progression rates between transmission risk groups has led to conflicting findings. An early study found significantly faster progression amongst homosexuals than heterosexuals [126]. However, more recent studies analysing much larger cohorts reported no difference in disease progression rates following adjustment for age and exclusion of Kaposi's sarcoma as an AIDS defining illness [62,127,128]. Prins et al. [127] noted that injecting drug users have a very high other-cause mortality rate that could confound results failing to take this into account.

The CASCADE collaboration [120] examined the change in morbidity and mortality between the pre- and post-HAART

periods. They found a reduction in mortality in the post-HAART era amongst homosexual and heterosexual risk groups but no such change in injecting drug users. This apparently higher risk of death than other groups may be related to poor therapy adherence, less access to HAART and the higher rate of co-morbid illnesses such as Hepatitis C. Other factors may have a larger role to play in clinical deterioration than the mode of transmission.

#### Psychosocial factors

Understanding the interaction between physical and psychosocial factors in disease progression is important to maximise holistic care for the patient. Several studies have found significant relationships between poorer clinical outcome and lack of satisfaction with social support, stressful life events, depression and denial-based coping strategies [129-132]. Other studies have found strong correlations between poorer adherence to therapy and depression, singleness and homelessness [106, 133]. Patient management should include consideration of the psychosocial context and aim to provide assistance in problem areas.

#### Resource limited settings

The three elements of host, immunological and virological factors obviously synergise to influence the progression of HIV infection, however, a few additional factors may hold prognostic value. While CD4 count and HIV RNA are the gold standard markers for disease monitoring, when measurement of these parameters is not possible surrogate markers become important. Markers investigated for their utility as simple markers for disease progression in resource-limited settings include delayed type hypersensitivity responses (DTH), total lymphocyte count (TLC), haemoglobin and body mass index (BMI).

#### Delayed type hypersensitivity

Mediated by CD4+ T-lymphocytes, DTH-type responses give an indication of CD4+ T-cell function in vivo. It has been

shown that DTH responses decline in parallel with CD4+ T-cells resulting in a corresponding increase in mortality [ 134, 135 ]. Failure to respond to a given number of antigens has been suggested as a marker for the initiation of ART in resource-limited settings [135,136].

Improved DTH responses have been noted with ART, although the degree of improvement appears dependent on the CD4+ nadir prior to HAART initiation [137-139]. This holds implications for the timing of initiation of treatment, as delayed treatment and hence low nadir CD4 counts may cause long-term immune deficits [139]. There is a need for further research in resource-limited settings to determine the utility of DTH testing as both a marker for HAART initiation and a means of monitoring its efficacy.

#### Total lymphocyte count

Another marker available in resource-limited countries, total lymphocyte count (TLC), has been investigated as an alternative to CD4+ T-cell count. Current WHO guidelines recommend using 1200 cells/mm<sup>3</sup> or below as a substitute marker for ART initiation in symptomatic patients [ 140]. Evidence for the predictive worth of this TLC level is encouraging, with several large studies confirming the significant association between a TLC of <1200 cells/mm<sup>3</sup> and subsequent disease progression or mortality [ 135, 141 , 142 ]. Others propose that rate of TLC decline should be used in disease monitoring as a rapid decline (33% per year) precedes the onset of AIDS by 1–2 years [ 142, 143 ]. Disappointingly, there is generally a poor correlation between TLC and CD4 count at specific given values.

While TLC measurement has been validated as a means of monitoring disease progression in ART-naïve patients, its use for therapeutic monitoring is questionable and not recommended [49,144-146].

#### Body mass index

The body mass index (BMI) is a simple and commonly used measure of nutritional status. Its relationship to survival in HIV infection is important for two main reasons. Firstly, 'wasting syndrome' (>10% involuntary weight loss in conjunction with chronic diarrhoea and weakness, +/-fever) is considered an AIDS defining illness according to the CDC classification of disease [1]. Secondly, the ease of measurement of this parameter makes it potentially highly useful as a marker for the initiation of ART in resource limited countries.

Like TLC, long-term monitoring of BMI is predictive of disease progression. A rapid decline has been noted in the 6 months preceding AIDS although the sensitivity of this measure was only 33% [145,146]. A baseline BMI of <20.3 kg/m<sup>2</sup> for men and <18.5 kg/m<sup>2</sup> for women is predictive of increased mortality, even in racially diverse cohorts, with a BMI of 17–18 kg/m<sup>2</sup> and <16 kg/m<sup>2</sup> being associated with a 2-fold and 5-fold risk of AIDS respectively [ 147 -149 ].

In combination with other simple markers such as haemoglobin, clinical staging and TLC, a BMI <18.5 kg/m<sup>2</sup> shows similar utility to CD4 count and HIV-RNA based guidelines for the initiation of HAART [150 , 151 ]. A sustained BMI <17 kg/m<sup>2</sup> 6 months after HAART initiation has been associated with a two-fold increase in risk of death [ 152 ].

As can be seen, measurement of the body mass index is a simple and useful predictor of disease progression. A BMI of <18.5 kg/m<sup>2</sup> was consistently strongly associated with increased risk of disease progression and may prove to be a valuable indicator of the need for HAART.

#### Haemoglobin

Haemoglobin levels reflect rapidity of disease progression rates and independently predict prognosis across demographically diverse cohorts [ 151 , 153]. Rates of haemo

globin decrease also correlate with falling CD4 counts [ 135, 141 ].

There have been suggestions that increases in haemoglobin are predictive of treatment success when combined with a TLC increase [ 143 ]. While racial variation in normal haemoglobin ranges and the side effects of antiretroviral agents such as zidovudine on the HIV infected bone marrow must be taken into account [144], monitoring haemoglobin levels shows utility in predicting disease progression both before and following HAART initiation.

### Conclusion

The evolution of HIV infection from the fusion of the first virion with a CD4+ T-cell to AIDS and death is influenced by a multitude of interacting factors. However, in gaining an understanding of the prognostic significance of just a few of these elements it may be possible to improve the management and long-term outcome for individuals. Host factors, although unalterable, remain important in considering the prognosis of the patient and guiding therapeutic regimens. Furthermore, research into host-virus interactions has great potential to enhance the development of new therapeutic strategies.

Immunological parameters such as levels of CD38 expression and the diversity of HIV-specific cytotoxic lymphocyte responses allow insight into the levels of autologous control of the virus. Virological monitoring, including drug resistance surveillance, will continue to play a considerable role in the management of HIV infection. Additionally, as access to antiretroviral therapy improves around the world, the utility of, and need for, low-cost readily available markers of disease is evident. As with any illness of such magnitude, it is clear that a multitude of factors must be taken into account in order to ensure optimum quality of life and treatment results.

### Competing interests

The author(s) declare that they have no competing interests.

### Appendix I

<sup>i</sup> The "Concerted Action of Seroconversion to AIDS and Death in Europe" (CASCADE) collaboration includes cohorts in France, Germany, Italy, Spain, Greece, Netherlands, Denmark, Norway, UK, Switzerland, Australia and Canada

<sup>ii</sup> The "TREAT Asia HIV Observational Database" (TAHOD) database contains observational information collected from 11 sites in the Asia-Pacific region, encompassing groups from Australia, India, the Philippines, Malaysia, China, Singapore and Thailand.

### References:

1. Fauci AS, Lane HC: Chapter 173. Human Immunodeficiency Virus Disease: AIDS and Related Disorders . In *Harrison's Principles of Internal Medicine Volume 1*. 16th edition. Edited by: Fauci AS, Lane HC. McGraw-Hill; 2005:p1076-1139.
2. Murray PR, Rosenthal KS, Pfaller MA: *Medical Microbiology. Volume 1*. 5th edition. Philadelphia, USA , Elsevier Mosby; 2005:963.
3. Miedema F: T cell dynamics and protective immunity in HIV infection: a brief history of ideas. *Current Opinion in HIV & AIDS* 2006, 1(1):1-2.
4. Pantaleo G, Fauci AS: IMMUNOPATHOGENESIS OF HIV INFECTION. *Annual Review of Microbiology* 1996, 50(1):825-854.
5. Osmond DH: Figure 1. Generalized time course of HIV infection and disease. Edited by: HIV EDP. HIV InSite Knowledge Base Chapter; 1998:Modified from: Centers for Disease Control and Prevention. Report of the NIH Panel to Define Principles of Therapy of HIV Infection and Guidelines for the Use of Antiretroviral Agents in HIV-Infected Adults and Adolescents. *MMWR* 1998;47(No. RR-5):Figure 1, page 34 .
6. Bartlett JG, Lane HC: Guidelines for the use of Antiretroviral Drugs in HIV-1-Infected Adults and Adolescents. In *Clinical Guidelines for the Treatment and Management of HIV Infection* Edited by: Infection PCPTHIV. USA , Department of Health and Human Services; 2005:1-118.
7. Stebbing J, Gazzard B, Douek DC: Mechanisms of disease Where does HIV live? *New England Journal of Medicine* 2004, 350(18):1872-1880.
8. Chinen J, Shearer WT: Molecular virology and immunology of HIV infection. *Journal of*



- Allergy and Clinical Immunology* 2002, 110(2):189-198.
9. Phillips AN, Lundgren JD: The CD4 lymphocyte count and risk of clinical progression. *Current Opinion in HIV & AIDS* 2006, 1(1):43-49.
  10. CASCADE collaboration: Short-term risk of AIDS according to current CD4 cell count and viral load in antiretroviral drug-naive individuals and those treated in the monotherapy era. *AIDS* 2004, 18(1):51-58.
  11. Zhou J, Kumarasamy N: Predicting short-term disease progression among HIV-infected patients in Asia and the Pacific region: preliminary results from the TREAT Asia HIV Observational Database (TAHOD). *HIV Medicine* 2005, 6(3):216-223.
  12. de Wolf F, Spijkerman I, Schellekens P, Langendam M, Kuiken C, Bakker M, Roos M, Coutinho R, Miedema F, Goudsmit J: AIDS prognosis based on HIV-1 RNA, CD4+ T-cell count and function: markers with reciprocal predictive value over time after seroconversion. *AIDS* 1997, 11(15):1799-1806.
  13. Lepri AC, Katzenstein TL, Ullum H, Phillips AN, Skinhoj P, Gerstoft J, Pedersen B: The relative prognostic value of plasma HIV RNA levels and CD4 lymphocyte counts in advanced HIV infection. *AIDS* 1998, 12(13):1639-1643.
  14. Hogg RS, Yip B, Chan KJ, Wood E, Craib KJP, O'Shaughnessy MV, Montaner JSG: Rates of Disease Progression by Baseline CD4 Cell Count and Viral Load After Initiating Triple-Drug Therapy. *JAMA* 2001, 286(20):2568-2577.
  15. Goujard C, Bonarek M, Meyer L, Bonnet F, Chaix ML, Deveau C, Sinet M, Galimand J, Delfraissy JF, Venet A, Rouzioux C, Morlat P: CD4 cell count and HIV DNA level are independent predictors of disease progression after primary HIV type 1 infection in untreated patients. *Clinical Infectious Diseases* 2006, 42(5):709-715.
  16. Moore RD, Chaisson RE: Natural history of HIV infection in the era of combination antiretroviral therapy. *AIDS* 1999, 13(14):1933-1942.
  17. Duncombe C, Kerr SJ, Ruxrungtham K, Dore GJ, Law MG, Emery S, Lange JA, Phanuphak P, Cooper DA: HIV disease progression in a patient cohort treated via a clinical research network in a resource limited setting. *Aids* 2005, 19(2):169-178.
  18. Grabar S, Moing VL, Goujard C, Lepout C, Kazatchkine MD, Costagliola D, Weiss L: Clinical Outcome of Patients with HIV-1 Infection according to Immunologic and Virologic Response after 6 Months of Highly Active Antiretroviral Therapy. *Ann Intern Med* 2000, 133(6):401-410.
  19. van Leth F, Andrews S, Grinsztejn B, Wilkins E, Lazanas MK, Lange JMA, Montaner J: The effect of baseline CD4 cell count and HIV-1 viral load on the efficacy and safety of nevirapine or efavirenz-based first-line HAART. *Aids* 2005, 19(5):463-471.
  20. Battegay M, Nuesch R, Hirschel B, Kaufmann GR: Immunological recovery and antiretroviral therapy in HIV-1 infection. *Lancet Infectious Diseases* 2006, 6(5):280-287.
  21. Ogg GS, Jin X, Bonhoeffer S, Dunbar PR, Nowak MA, Monard S, Segal JP, Cao Y, Rowland-Jones SL, Cerundolo V, Hurley A, Markowitz M, Ho DD, Nixon DF, McMichael AJ: Quantitation of HIV-1-specific cytotoxic T lymphocytes and plasma load of viral RNA. *Science* 1998, 279(5359):2103-2106.
  22. Keoshkerian E, Ashton LJ, Smith DG, Ziegler JB, Kaldor JM, Cooper DA, Stewart GJ, French RA: Effector HIV-specific cytotoxic T-lymphocyte activity in long-term nonprogressors: Associations with viral replication and progression. *Journal of Medical Virology* 2003, 71(4):483-491.
  23. Oxenius A, Price DA, Hersberger M, Schlaepfer E, Weber R, Weber M, Kundig TM, Böni J, Joller H, Phillips RE, Flepp M, Opravil M, Speck RF: HIV-specific cellular immune response is inversely correlated with disease progression as defined by decline of CD4+ T cells in relation to HIV RNA load. *The journal of infectious diseases* 2004, 189(7):1199-1208.
  24. Chouquet C, Autran B, Gomard E, Bouley JM, Calvez V, Katlama C, Costagliola D, Rivière Y: Correlation between breadth of memory HIV-specific cytotoxic T cells, viral load and disease progression in HIV infection. *AIDS* 2002, 16(18):2399-2407.
  25. Macias J, Leal M, Delgado J, Pineda JA, Munoz J, Relimpio F, Rubio A, Rey C, Lissen E: Usefulness of route of transmission, absolute CD8+T-cell counts, and levels of serum tumor necrosis factor alpha as predictors of survival of HIV-1-infected patients with very low CD4+T-cell counts. *European Journal of Clinical Microbiology & Infectious Diseases* 2001, 20(4):253-259.
  26. Bonnet F, Thiebaut R, Chene G, Neau D, Pellegrin JL, Mercie P, Beylot J, Dabis F, Salamon R, Morlat P: Determinants of clinical progression in antiretroviral-naive HIV-infected patients starting highly active antiretroviral therapy. Aquitaine Cohort, France, 1996-2002. *Hiv Medicine* 2005, 6(3):198-205.

27. Hazenberg MD, Otto SA, van Benthem BHB, Roos MTL, Coutinho RA, Lange JMA, Hamann D, Prins M, Miedema F: Persistent immune activation in HIV-1 infection is associated with progression to AIDS. *Aids* 2003, 17(13):1881-1888.
28. Brenchley JM, Price DA, Schacker TW, Asher TE, Silvestri G, Rao S, Kazzaz Z, Bornstein E, Lambotte O, Altmann D, Blazar BR, Rodriguez B, Teixeira-Johnson L, Landay A, Martin JN, Hecht FM, Picker LJ, Lederman MM, Deeks SG, Douek DC: Microbial translocation is a cause of systemic immune activation in chronic HIV infection. *Nature Medicine* 2006, 12(12):1365-1371.
29. Kaushik S, Vajpayee M, Sreenivas V, Seth P: Correlation of T-lymphocyte subpopulations with immunological markers in HIV-1-infected Indian patients. *Clinical Immunology* 2006, 119(3):330-338.
30. Scriba TJ, Zhang HT, Brown HL, Oxenius A, Tamm N, Fidler S, Fox J, Weber JN, Klenerman P, Day CL, Lucas M, Phillips RE: HIV-1-specific CD4+ T lymphocyte turnover and activation increase upon viral rebound. *Journal of Clinical Investigation* 2005, 115(2):443-450.
31. Deeks SG, Walker BD: The immune response to AIDS virus infection: good, bad or both? *Journal of Clinical Investigation* 2004, 113(6):808-810.
32. Benito DM, Lopez M, Lozano S, Ballesteros C, Martinez P, Gonzalez-Lahoz J, Soriano V: Differential upregulation of CD38 on different T-cell subsets may influence the ability to reconstitute CD4(+) T cells under successful highly active antiretroviral therapy. *Aids-Journal of Acquired Immune Deficiency Syndromes* 2005, 38(4):373-381.
33. Benito JM, Lopez M, Lozano S, Martinez P, Gonzalez-Lahoz J, Soriano V: CD38 expression on CD8(+) T lymphocytes as a marker of residual virus replication in chronically HIV-infected patients receiving antiretroviral therapy. *Aids Research and Human Retroviruses* 2004, 20(2):227-233.
34. Giorgi JV, Hultin LE, McKeating JA, Johnson TD, Owens B, Jacobson LP, Shih R, Lewis J, Wiley DJ, Phair JP, Wolinsky SM, Detels R: Shorter survival in advanced human immunodeficiency virus type 1 infection is more closely associated with T lymphocyte activation than with plasma virus burden or virus chemokine coreceptor usage. *Journal of Infectious Diseases* 1999, 179(4):859-870.
35. Eggena MP, Barugahare B, Okello M, Mutyala S, Jones N, Ma YF, Kityo C, Mugenyi P, Cao H: T cell activation in HIV-seropositive Ugandans: Differential associations with viral load, CD4(+) T cell depletion, and coinfection. *Journal of Infectious Diseases* 2005, 191(5):694-701.
36. Deeks SG, Kitchen CM, Liu L, Guo H, Gascon R, Narvaez AB, Hunt P, Martin JN, Kahn JO, Levy J, McGrath MS, Hecht FM: Immune activation set point during early FHV infection predicts subsequent CD4(+) T-cell changes independent of viral load. *Blood* 2004, 104(4):942-947.
37. Wilson CM, Ellenberg JH, Douglas SD, Moscicki AB, Holland CA: CD8(+)CD38(+) T cells but not HIV type 1 RNA viral load predict CD4(+) T cell loss in a predominantly minority female HIV+ adolescent population. *Aids Research and Human Retroviruses* 2004, 20(3):263-269.
38. Connolly NC, Ridder SA, Rinaldo CR: Proinflammatory cytokines in HIV disease - a review and rationale for new therapeutic approaches. *AIDS Reviews* 2005, 7:168-180.
39. Spear GT, Alves MEAF, Cohen MH, Bremer J, Landay AL: Relationship of HIV RNA and cytokines in saliva from HIV-infected individuals. *FEMS Immunology and Medical Microbiology* 2005, 45:129-136.
40. Majumder B, Janket ML, Schafer EA, Schaubert K, Huang XL, Kan-Mitchell J, Rinaldo J Charles R., Ayyavoo V: Human Immunodeficiency Virus Type 1 Vpr Impairs Dendritic Cell Maturation and T-Cell Activation: Implications for Viral Immune Escape. *JOURNAL OF VIROLOGY* 2005, 79(13):7990-8003.
41. Fahey JL, Taylor JM, Detels R, Hofmann B, Melmed R, Nishanian P, Giorgi JV: The prognostic value of cellular and serologic markers in infection with human immunodeficiency virus type 1. *N Engl J Med* 1990, 322(3):166-172.
42. Fahey JL, Taylor JMG, Manna B, Nishanian P, Aziz N, Giorgi JV, Detels R: Prognostic significance of plasma markers of immune activation, HIV viral load and CD4 T-cell measurements. *AIDS* 1998, 12(13):1581-1590.
43. Mildvan D, Spritzler J, Grossberg SE, Fahey JL, Johnston DM, Schock BR, Kagan J: Serum neopterin, an immune activation marker, independently predicts disease progression in advanced HIV-1 infection. *Clinical Infectious Diseases* 2005, 40(6):853-858.
44. Shi MG, Taylor JMG, Fahey JL, Hoover DR, Munoz A, Kingsley LA: Early levels of CD4, neopterin, and beta(2)-microglobulin indicate future disease progression. *Journal of Clinical Immunology* 1997, 17(1):43-52.

45. Zangerle R, Steinhuber S, Sarcletti M, Dierich MP, Wachter H, Fuchs D, Most J: Serum HIV-1 RNA levels compared to soluble markers of immune activation to predict disease progression in HIV-1-infected individuals. *International Archives of Allergy and Immunology* 1998, 116(3):228-239.
46. Stein DS, Lyles RH, Graham NMH, Tassoni CJ, Margolick JB, Phair JP, Rinaldo C, Detels R, Saah A, Bilello J: Predicting clinical progression or death in subjects with early-stage human immunodeficiency virus (HIV) infection: A comparative analysis of quantification of HIV RNA, soluble tumor necrosis factor type II receptors, neopterin, and beta(2)-microglobulin. *Journal of Infectious Diseases* 1997, 176(5):1161-1167.
47. O'Brien WA, Hartigan PM, Martin D, Esinhart J, Hill A, Benoit S, Rubin M, Simberkoff MS, Hamilton JD: Changes in Plasma HIV-1 RNA and CD4+ Lymphocyte Counts and the Risk of Progression to AIDS. *N Engl J Med* 1996, 334(7):426-431.
48. Mellors JW, Munoz A, Giorgi JV, Margolick JB, Tassoni CJ, Gupta P, Kingsley LA, Todd JA, Saah AJ, Detels R, Phair JP, Rinaldo CR Jr.: Plasma Viral Load and CD4+ Lymphocytes as Prognostic Markers of HIV-1 Infection. *Annals of Internal Medicine* 1997, 126(12):946-954.
49. Hammer S, WHO Guidelines Development Group: Antiretroviral therapy for HIV infection in Adults and Adolescents in resource-limited settings: Towards Universal Access Recommendations for a public health approach (2006 revision). In *Antiretroviral therapy for HIV infection in Adults and Adolescents in resource-limited settings: Towards Universal Access* Edited by: Hammer S. Geneva, WHO; 2006.
50. Gazzard B, BHIVA writing committee: British HIV Association (BHIVA) guidelines for the treatment of HIV-infected adults with antiretroviral therapy (2005). *HIV medicine* 2005, 6(Sup-plement 2):1-61.
51. Bhatia R, Narain JP: Guidelines for HIV DIAGNOSIS and Monitoring of ANTIRETROVIRAL THERAPY -South East Asia Regional Branch. *World Health Organisation Publications* 2005.
52. Lyles RH, Munoz A, Yamashita TE, Bazmi H, Detels R, Rinaldo CR, Margolick JB, Phair JP, Mellors JW: Natural history of human immunodeficiency virus type 1 viremia after seroconversion and proximal to AIDS in a large cohort of homosexual men. *Journal of Infectious Diseases* 2000, 181(3):872-880.
53. Thiebaut R, Pellegrin I, Chene G, Viallard JF, Fleury H, Moreau JF, Pel-legrin JL, Blanco P: Immunological markers after long-term treatment interruption in chronically HIV-1 infected patients with CD4 cell count above 400x10(6) cells/l. *Aids* 2005, 19(1):53-61.
54. Arnaout RA, Lloyd AL, O'Brien TR, Goedert JJ, Leonard JM, Nowak MA: A simple relationship between viral load and survival time in HIV-1 infection. *Proceedings of the National Academy of Sciences of the United States of America* 1999, 96(20):11549-11553.
55. Arduino JM, Fischl MA, Stanley K, Collier AC, Spiegelman D: Do HIV type 1 RNA levels provide additional prognostic value to CD4(+) T lymphocyte counts in patients with advanced HIV type 1 infection? *Aids Research and Human Retroviruses* 2001, 17(12):1099-1105.
56. Ledergerber B: Predictors of trend in CD4-positive T-cell count and mortality among HIV-1-infected individuals with virological failure to all three antiretroviral-drug classes. *The Lancet* 2004, 364(9428):51-62.
57. Touloumi G, Hatzakis A, Rosenberg PS, O'Brien TR, Goedert JJ: Effects of age at seroconversion and baseline HIV RNA level on the loss of CD4+ cells among persons with hemophilia. *Aids* 1998, 12(13):1691-1697.
58. Ho DD: Dynamics of HIV-1 replication in vivo. *Journal of Clinical Investigation* 1997, 99(11):2565-2567.
59. Hubert JB, Burgard M, Dussaix E, Tamalet C, Deveau C, Le Chenadec J, Chaix ML, Marchadier E, Vilde JL, Delfraissy JF, Meyer L, Rouzioux C: Natural history of serum HIV-1 RNA levels in 330 patients with a known date of infection. *Aids* 2000, 14(2):123-131.
60. Relucio K, Holodniy M: HIV-1 RNA and viral load. *Clinics in Laboratory Medicine* 2002, 22(3):593-+.
61. Bajaria SH, Webb G, Cloyd M, Kirschner D: Dynamics of naive and memory CD4(+) T lymphocytes in HIV-1 disease progression. *Journal of Acquired Immune Deficiency Syndromes* 2002, 30(1):41-58.
62. CASCADE collaboration, Babiker A, Darby S, De Angelis D, Kwart D, Porter K, Beral V, Darbyshire J, Day N, Gill N, Coutinho R, Prins M, van Benthem B, Coutinho R, Dabis F, Marimoutou C, Ruiz I, Tusell J, Altisent C, Evatt B, Jaffe H, Kirk O, Pedersen C, Rosenberg P, Goedert J, Biggar R, Melbye M, Brettle R, Downs A, Hamouda O, Touloumi G, Karafoulidou A, Katsarou O, Donfield S, Gomperts E, Hilgartner M, Hoots K, Schoenbaum E, Beral V, Zangerle R, Del Amo J, Pezzotti P, Rezza G, Hutchinson S, Day N, De Angelis D, Gore S, Kingsley L, Schragger L,

- Rosenberg P, Goedert J, Melnick S, Koblin B, Eskild A, Bruun J, Sannes M, Evans B, Lepri AC, Sabin C, Buchbinder S, Vittinghoff E, Moss A, Osmond D, Winkelstein W, Goldberg D, Boufassa F, Meyer L, Egger M, Francioli P, Rickenbach M, Cooper D, Tindall B, Sharkey T, Vizzard J, Kaldor J, Cunningham P, Vanhems P, Vizzard J, Kaldor J, Learmont J, Farewell V, Berglund O, Mosley J, Operskalski E, van den Berg M, Metzger D, Tobin D, Woody G, Rusnak J, Hendrix C, Garner R, Hawkes C, Renzullo P, Garland F, Darby S, Ewart D, Giangrande P, Lee C, Phillips A, Spooner R, Wilde J, Winter M, Babiker A, Darbyshire J, Evans B, Gill N, Johnson A, Phillips A, Porter K, Lorenzo JI, Schechter M: Time from HIV-1 seroconversion to AIDS and death before widespread use of highly-active antiretroviral therapy: a collaborative re-analysis. *Lancet* 2000, 355(9210):1131-1137.
63. Desquilbet L, Goujard C, Rouzioux C, Sinet M, Deveau C, Chaix ML, Sereni D, Boufassa F, Delfraissy JF, Meyer L: Does transient HAART during primary HIV-1 infection lower the virological set-point? *Aids* 2004, 18(18):2361-2369.
  64. Olsen CHG Jose b; Ledergerber, Bruno c; Katlama, Christine d; Friis-Moller, Nina a; Weber, Jonathan e; Horban, Andrzej f; Staszewski, Schlomo g; Lundgren, Jens D a; Phillips, Andrew N h; for the EuroS-IDA Study Group \*: Risk of AIDS and death at given HIV-RNA and CD4 cell count, in relation to specific antiretroviral drugs in the regimen. *AIDS* 2005, 19(3):319-330.
  65. Raboud JM, Rae S, Hogg RS, Yip B, Sherlock CH, Harrigan PR, O'Shaughnessy MV, Montaner JS: Suppression of plasma virus load below the detection limit of a human immunodeficiency virus kit is associated with longer virologic response than suppression below the limit of quantitation. *The journal of infectious diseases* 1999, 180(4):1347-1350.
  66. Raboud JM, Montaner JSG, Conway B, Rae S, Reiss P, Vella S, Cooper D, Lange O, Harris M, Wainberg MA, Robinson P, Myers M, Hall D: Suppression of plasma viral load below 20 copies/ml is required to achieve a long-term response to therapy. *Aids* 1998, 12(13):1619-1624.
  67. Kempf DJ, Rode RA, Xu Y, Sun E, Heath-Chiozzi ME, Valdes J, Japour AJ, Danner S, Boucher C, Molla A, Leonard JM: The duration of viral suppression during protease inhibitor therapy for HIV-1 infection is predicted by plasma HIV-1 RNA at the nadir. *AIDS* 1998, 12(5):F9-F14.
  68. Tarwater PM, Gallant JE, Mellors JW, Gore ME, Phair JP, Detels R, Margolick JB, Munoz A: Prognostic value of plasma HIV RNA among highly active antiretroviral therapy users. *Aids* 2004, 18(18):2419-2423.
  69. Raffanti SP, Fusco JS, Sherrill BH, Hansen NI, Justice AC, D' Aquila R, Mangialardi WJ, Fusco GP: Effect of persistent moderate viremia on disease progression during HIV therapy. *J AIDS-Journal of Acquired Immune Deficiency Syndromes* 2004, 37(1):1147-1154.
  70. Murri R, Lepri AC, Cicconi P, Poggio A, Arlotti M, Tositti G, Santoro D, Soranzo ML, Rizzardini G, Colangeli V, Montroni M, Monforte AD: Is moderate HIV viremia associated with a higher risk of clinical progression in HIV-Infected people treated with highly active Antiretroviral therapy - Evidence from the Italian Cohort of Antiretroviral-Naive Patients Study. *J AIDS-Journal of Acquired Immune Deficiency Syndromes* 2006, 41(1):23-30.
  71. Nettles RE, Kieffer TL, Kwon P, Monie D, Han YF, Parsons T, Cofrancesco J, Gallant JE, Quinn TC, Jackson B, Flexner C, Carson K, Ray S, Persaud D, Siliciano RF: Intermittent HIV-1 viremia (blips) and drug resistance in patients receiving HAART. *Jama-Journal of the American Medical Association* 2005, 293(7):817-829.
  72. Havlir DV, Bassett R, Levitan D, Gilbert P, Tebas P, Collier AC, Hirsch MS, Ignacio C, Condra J, Gunthard HF, Richman DD, Wong JK: Prevalence and Predictive Value of Intermittent Viremia With Combination HIV Therapy. *JAMA* 2001, 286(2):171-179.
  73. Martinez V, Marcelin AG, Morini JP, Deleuze J, Krivine A, Gorin I, Yerly S, Perrin L, Peytavin G, Calvez V, Dupin N: HIV-1 intermittent viraemia in patients treated by non-nucleoside reverse transcriptase inhibitor-based regimen. *AIDS* 2005, 19(10):1065-1069.
  74. Siliciano JD, Kajdas J, Finzi D, Quinn TC, Chadwick K, Margolick JB, Kovacs C, Gange SJ, Siliciano RF: Long-term follow-up studies confirm the stability of the latent reservoir for HIV-1 in resting CD4(+) T cells. *Nature Medicine* 2003, 9(6):727-728.
  75. Haggerty CM, Pitt E, Siliciano RF: The latent reservoir for HIV-1 in resting CD4+ T cells and other viral reservoirs during chronic infection: insights from treatment and treatment-interruption trials. *Current Opinion in HIV & AIDS* 2006, 1(1):62-68.
  76. Siliciano JD, Siliciano RF: The latent reservoir for HIV-1 in resting CD4R T cells: a barrier to cure. *Current Opinion in HIV and AIDS* 2006, 1(2):121-128.

77. Chun TW, Nickle DC, Justement JS, Large D, Semerjian A, Curlin ME, O'Shea MA, Hallahan CW, Daucher M, Ward DJ, Moir S, Mullins JI, Kovacs C, Fauci AS: HIV-infected individuals receiving effective antiviral therapy for extended periods of time continually replenish their viral reservoir. *The journal of clinical investigation* 2005, 115(11):3250-3255.
78. Anton PA, Mitsuyasu RT, Deeks SG, Scadden DT, Wagner B, Huang C, Macken C, Richman DD, Christopherson C, Borellini F, Lazar R, Hege KM: Multiple measures of HIV burden in blood and tissue are correlated with each other but not with clinical parameters in aviremic subjects. *AIDS* 2003, 17(1):53-63.
79. Vitone F, Gibellini D, Schiavone P, Re MC: Quantitative DNA pro viral detection in HIV-1 patients treated with antiretroviral therapy. *Journal of Clinical Virology* 2005, 33(3):194-200.
80. Vray M, Meynard JL, Dalban C, Morand-Joubert L, Clavel F, Brun-Vezinet F, Peytavin G, Costagliola D, Girard PM, Group NT: Predictors of the virological response to a change in the antiretroviral treatment regimen in HIV-1-infected patients enrolled in a randomized trial comparing genotyping, phenotyping and standard of care (Narval trial, ANRS 088). *Antiviral therapy* 2003, 8(5):427-434.
81. Rodes B, Garcia F, Gutierrez C, Martinez-Picado J, Aguilera A, Sau-moy M, Vallejo A, Domingo P, Dalmau D, Ribas MA, Blanco JL, Pedreira J, Perez-Elias MJ, Leal M, de Mendoza C, Soriano V: Impact of drug resistance genotypes on CD4+counts and plasma viremia in heavily antiretroviral-experienced HIV-infected patients. *Journal of Medical Virology* 2005, 77(1):23-28.
82. Deeks SG: Determinants of virological response to antiretroviral therapy: Implications for long-term strategies. *Clinical Infectious Diseases* 2000, 30:S177-S184.
83. Lucas GM: Antiretroviral adherence, drug resistance, viral fitness and HIV disease progression: a tangled web is woven. *Journal of Antimicrobial Chemotherapy* 2005, 55(4):413-416.
84. Deeks SG: Treatment of antiretroviral-drug-resistant HIV-1 infection. *Lancet* 2003, 362(9400):2002-2011.
85. Vandamme AM, Sonnerborg A, Ait-Khaled M, Albert J, Asjo B, Bachelier L, Banhegyi D, Boucher C, Brun-Vezinet F, Camacho R, Clevenbergh P, Clumeck N, Dedes N, De Luca A, Doerr HW, Faudon JL, Gatti G, Gerstoft J, Hall WW, Hatzakis A, Hellmann N, Horban A, Lundgren JD, Kempf D, Miller M, Miller V, Myers TW, Nielsen C, Opravil M, Palmisano L, Perno CF, Phillips A, Pillay D, Pumarola T, Ruiz L, Salminen M, Schapiro J, Schmidt B, Schmit JC, Schuurman R, Shulze E, Soriano V, Staszewski S, Vella S, Youle M, Ziermann R, Per-rin L: Updated European recommendations for the clinical use of HIV drug resistance testing. *Antiviral Therapy* 2004, 9(6):829-848.
86. Oette M, Kaiser R, Daumer M, Petch R, Fatkenhetter G, Carls H, Rockstroh JK, Schmalzer D, Stechel J, Feldt T, Pfister H, Haussinger D: Primary HIV drug resistance and efficacy of first-line antiretroviral therapy guided by resistance testing. *Aids-Journal of Acquired Immune Deficiency Syndromes* 2006, 41(5):573-581.
87. Shet A, Berry L, Mohri H, Mehandru S, Chung C, Kim A, Jean-Pierre P, Hogan C, Simon V, Boden D, Markowitz MT: Tracking the prevalence of transmitted antiretroviral drug-resistant HIV-1 - A decade of experience. *Aids-Journal of Acquired Immune Deficiency Syndromes* 2006, 41(4):439-446.
88. Wensing AMJ, van de Vijver DA, Angarano G, Asjo B, Balotta C, Boeri E, Camacho R, Chaix ML, Costagliola D, De Luca A, Derdelinckx I, Grossman Z, Hamouda O, Hatzakis A, Hemmer R, Hoepelman A, Horban A, Korn K, Kucherer C, Leitner T, Loveday C, MacRae E, Maljkovic I, de Mendoza C, Meyer L, Nielsen C, de Coul ELO, Ormaasen V, Paraskevis D, Perrin L, Puchhammer-Stockl E, Ruiz L, Salminen M, Schmit JC, Schneider F, Schuurman R, Soriano V, Stanczak G, Stanojevic M, Vandamme AM, Van Laethem K, Violin M, Wilbe K, Yerly S, Zazzi M, Boucher CA: Prevalence of drug-resistant HIV-1 variants in untreated individuals in Europe: Implications for clinical management. *Journal of Infectious Diseases* 2005, 192(6):958-966.
89. Jourdain G, Ngo-Giang-Huong N, Le Coeur S, Bowonwatanuwong C, Kantipong P, Leechanachai P, Ariyadej S, Leenasirimakul P, Hammer S, Lallemand M: Intrapartum exposure to nevirapine and subsequent maternal responses to nevirapine-based antiretroviral therapy. *New England Journal of Medicine* 2004, 351(3):229-240.
90. Melby T, DeSpirito M, DeMasi R, Heilek-Snyder G, Greenberg ML, Graham N: HIV-1 coreceptor use in triple-class treatment experienced patients: Baseline prevalence, correlates, and relationship to enfuvirtide response. *Journal of Infectious Diseases* 2006, 194(2):238-246.

91. Daar ES, Lynn HS, Donfield SM, Lail A, O'Brien SJ, Huang W, Winkler CA: Stromal cell-derived factor-1 genotype, coreceptor tropism, and HIV type 1 disease progression. *Journal of Infectious Diseases* 2005, 192(9):1597-1605.
92. Brumme ZL, Goodrich J, Mayer HB, Brumme CJ, Henrick BM, Wynhoven B, Asselin JJ, Cheung PK, Hogg RS, Montaner JSG, Harrigan PR: Molecular and clinical epidemiology of CXCR4-using HIV-1 in a large population of antiretroviral-naive individuals. *Journal of Infectious Diseases* 2005, 192(3):466-474.
93. Kaslow RA, Dorak T, Tang J: Influence of host genetic variation on susceptibility to HIV type 1 infection. *Journal of Infectious Diseases* 2005, 191:S68-S77.
94. Liu HL, Hwangbo Y, Holte S, Lee J, Wang CH, Kaupp N, Zhu HY, Celum C, Corey L, McElrath MJ, Zhu TF: Analysis of genetic polymorphisms in CCR5, CCR2, stromal cell-derived factor-1, RANTES, and dendritic cell-specific intercellular adhesion molecule-3-grabbing nonintegrin in seronegative individuals repeatedly exposed to HIV-1. *Journal of Infectious Diseases* 2004, 190(6):1055-1058.
95. Hogan CM, Hammer SM: Host determinants in HIV infection and disease - Part 2: Genetic factors and implications for antiretroviral therapeutics. *Annals of Internal Medicine* 2001, 134(10):978-996.
96. Delobel P, Sandres-Saune K, Cazabat M, Pasquier C, Marchou B, Mas-sip P, Izopet J: R5 to X4 switch of the predominant HIV-1 population in cellular reservoirs during effective highly active antiretroviral therapy. *J AIDS-Journal of Acquired Immune Deficiency Syndromes* 2005, 38(4):382-392.
97. Skrabal K, Trouplin V, Labrosse B, Obry V, Damond F, Hance AJ, Clavel F, Mammano F: Impact of antiretroviral treatment on the tropism of HIV-1 plasma virus populations. *Aids* 2003, 17(6):809-814.
98. Brumme ZL, Dong WWY, Yip B, Wynhoven B, Hoffman NG, Swanstrom R, Jensen MA, Mullins JI, Hogg RS, Montaner JSG, Harrigan PR: Clinical and immunological impact of HIV envelope V3 sequence variation after starting initial triple antiretroviral therapy. *Aids* 2004, 18(4):F1-F9.
99. Geretti AM: HIV-1 subtypes: epidemiology and significance for HIV management. *Current opinion in infectious diseases* 2006, 19(1):1-7.
100. Rangsri R, Chiu J, Khamboonruang C, Sirisopana N, Eiumtrakul S, Brown AE, Robb M, Beyrer C, Ruangyuttikarn C, Markowitz LE, Nelson KE: The Natural History of HIV-1 Infection in Young Thai Men After Seroconversion. *J Acquired Immune Deficiency Syndromes* 2004, 36(1):622-629.
101. Hu DJ, Vanichseni S, Mastro TD, Raktham S, Young NL, Mock PA, Subbarao S, Parekh BS, Srisuwanvilai L, Sutthent R, Wasi C, Heneine W, Choopanya K: Viral load differences in early infection with two HIV-1 subtypes. *Aids* 2001, 15(6):683-691.
102. Kaleebu P, French N, Mahe C, Yirell D, Watera C, Lyagoba F, Nakiyingi J, Rutebemberwa A, Morgan D, Weber J, Gilks C, Whitworth J: Effect of human immunodeficiency virus (HIV) type 1 envelope subtypes A and D on disease progression in a large cohort of HIV-1-positive persons in Uganda. *Journal of Infectious Diseases* 2002, 185(9):1244-1250.
103. Alaeus A, Lidman K, Bjorkman A, Giesecke J, Albert J: Similar rate of disease progression among individuals infected with HIV 1 genetic subtypes A-D. *AIDS* 1999, 13(8):901-907.
104. Gray L, Newell ML, Cortina-Borja M, Thorne C: Gender and race do not alter early-life determinants of clinical disease progression in HIV-1 vertically infected children - European Collaborative Study. *Aids* 2004, 18(3):509-516.
105. Stephenson JM, Griffioen A, Woronowski H, Phillips AN, Petrucci A, Keenlyside R, Johnson AM, Anderson J, Melville R, Jeffries DJ, Norman J, Barton S, Chard S, Sibley K, Mitchelmore M, Brettler R, Morris S, O'Dornen P, Russell J, Overington-Hickford L, O'Farrell N, Chappell J, Mulcahy RF, Moseley J, Lyons F, Welch J, Graham D, Fadojutimi M, Kitchen V, Wells C, Byrne G, Tobin J, Tucker L, Harindira V, Mercey DE, Allason-Jones E, Campbell L, French R, Johnson MA, Reid A, Farmer D, Saint N, Olaitan A, Madge S, Forster G, Phillips M, Sampson K, Nayagam A, Edlin J, Bradbeer C, de Ruiter A, Hargreaves L, Doyle C: Survival and progression of HIV disease in women attending GUM/HIV clinics in Britain and Ireland. *Sexually Transmitted Infections* 1999, 75(4):247-252.
106. Anastos K, Schneider MF, Gange SJ, Minkoff H, Greenblatt RM, Feldman J, Levine A, Delapenha R, Cohen M: The association of race, sociodemographic, and behavioral characteristics with response to highly active antiretroviral therapy in women. *J AIDS-Journal of Acquired Immune Deficiency Syndromes* 2005, 39(5):537-544.
107. Anastos K, Gange SJ, Lau B, Weiser B, Detels R, Giorgi JV, Margolick JB, Cohen M, Phair J, Melnick S, Rinaldo CR, Kovacs A, Levine A,

- Landesman S, Young M, Munoz A, Greenblatt RM: Association of race and gender with HIV-1 RNA levels and immunologic progression. *JAIDS* 2000, 24(3):218-226.
108. Saul J, Erwin J, Sabin CA, Kulasegaram R, Peters BS: The relationships between ethnicity, sex, risk group, and virus load in human immunodeficiency virus type 1 antiretroviral-naïve patients. *Journal of Infectious Diseases* 2001, 183(10):1518-1521.
  109. Brown AE, Malone JD, Zhou SY, Lane JR, Hawkes CA: Human immunodeficiency virus RNA levels in US adults: a comparison based upon race and ethnicity. *The journal of infectious diseases* 1997, 176(3):794-797.
  110. Morgan D, Mahe C, Mayanja B, Okongo JM, Lubega R, Whitworth JAG: HIV-1 infection in rural Africa: is there a difference in median time to AIDS and survival compared with that in industrialized countries? *Aids* 2002, 16(4):597-603.
  111. Julg B, Goebel FD: Susceptibility to HIV/AIDS: An individual characteristic we can measure? *Infection* 2005, 33(3):160-162.
  112. Altfeld M, Addo MA, Rosenberg ES, Hecht FA, Lee PK, Vogel M, Yu XG, Draenert R, Johnston MN, Strick D, Allen TA, Feeney ME, Kahn JO, Sekaly RP, Levy JA, Rockstroh JK, Goulder PJR, Walker BD: Influence of HLA-B\*57 on clinical presentation and viral control during acute HIV-1 infection. *Aids* 2003, 17(18):2581-2591.
  113. Boffito M, Winston A, Owen A: Host determinants of antiretroviral drug activity. *Current opinion in infectious diseases* 2005, 18(6):543-549.
  114. Phillips EJ: The pharmacogenetics of antiretroviral therapy. *Current Opinion in HIV and AIDS* 2006, 1(3):249-256.
  115. Haas DW: Pharmacogenomics and HIV therapeutics. *Journal of Infectious Diseases* 2005, 191(9):1397-1400.
  116. Nash D, Katyal M, Shah S: Trends in predictors of death due to HIV-related causes among persons living with AIDS in New York City: 1993-2001. *Journal of Urban Health-Bulletin of the New York Academy of Medicine* 2005, 82(4):584-600.
  117. Darby SC, Ewart DW, Giangrande PLF, Spooner RJD, Rizza CR: Importance of age at infection with HIV-1 for survival and development of AIDS in UK haemophilia population. *Lancet* 1996, 347(9015):1573-1579.
  118. Operskalski EA, Stram DO, Lee H, Zhou Y, Donegan E, Busch MP, Stevens CE, Schiff ER, Dietrich SL, Mosley JW: Human-Immunodeficiency-Virus Type-1 Infection - Relationship of Risk Group and Age to Rate of Progression to Aids. *Journal of Infectious Diseases* 1995, 172(3):648-655.
  119. Geskus RB, Meyer L, Hubert JB, Schuitemaker H, Berkhout B, Rouz-ioux C, Theodorou ID, Delfraissy JF, Prins M, Coutinho RA: Causal pathways of the effects of age and the CCR5-Delta 32, CCR2-641, and SDF-1 3' A alleles on AIDS development. *Jaid-Journal of Acquired Immune Deficiency Syndromes* 2005, 39(3):321-326.
  120. CASCADE collaboration, Porter K, Babiker AG, Darbyshire JH, Pezzotti P, Bhaskaran K, Walker AS: Determinants of survival following HIV-1 seroconversion after the introduction of HAART. *Lancet* 2003, 362(9392):1267-1274.
  121. Touloumi G, Pantazis N, Babiker AG, Walker SA, Katsarou O, Kara-foulidou A, Hatzakis A, Porter K: Differences in HIV RNA levels before the initiation of antiretroviral therapy among 1864 individuals with known HIV-1 seroconversion dates. *Aids* 2004, 18(12):1697-1705.
  122. Sterling TR, Vlahov D, Astemborski J, Hoover DR, Margolick JB, Quinn TC: Initial Plasma HIV-1 RNA Levels and Progression to AIDS in Women and Men. *N Engl J Med* 2001, 344(10):720-725.
  123. Farzadegan H, Hoover DR, Astemborski J, Lyles CM, Margolick JB, Markham RB, Quinn TC, Vlahov D: Sex differences in HIV-1 viral load and progression to AIDS. *Lancet* 1998, 352:1510-1514.
  124. Donnelly CA, Bartley LM, Ghani AC, LeVre AM, Kwong GP, Cowling BJ, van Sighem AI, de Wolf F, Rode RA, Anderson RM: Gender difference in HIV-1 RNA viral loads. *HIV medicine* 2005, 6(3):170-178.
  125. Sterling TR, Chaisson RE, Moore RD: HIV-1 RNA, CD4 T-lymphocytes, and clinical response to highly active antiretroviral therapy. *AIDS* 2001, 15(17):2251-2257.
  126. Carre N, Deveau C, Belanger F, Boufassa F, Persoz A, Jadand C, Rouz-ioux C, Delfraissy JF, Bucquet D, Dellamonica P, Gallais H, Dormont J, Lefrere JJ, Cassuto JP, Dupont B, Vittecoq D, Herson S, Gastaut JA, Sereni D, Vilde JL, Brucker G, Katlama C, Sobel A, Duval J, Kazatchine M, Lebras P, Even P, Guillemin L: Effect of Age and Exposure Group on the Onset of Aids in Heterosexual and Homosexual HIV-Infected Patients. *Aids* 1994, 8(6):797-802.
  127. Prins M, Veugelers PJ: Comparison of progression and non-progression in injecting drug users and homosexual men with

- documented dates of HIV-1 seroconversion. *Aids* 1997, 11(5):621-631.
128. Rezza G: Determinants of progression to AIDS in HIV-infected individuals: An update from the Italian Seroconversion Study. *Journal of Acquired Immune Deficiency Syndromes and Human Retrovirology* 1998, 17:S13-S16.
  129. Ironson G, O'Leirigh C, Fletcher MA, Laurenceau JP, Balbin E, Klimas N, Schneiderman N, Solomon G: Psychosocial Factors Predict CD4 and Viral Load Change in Men and Women With Human Immunodeficiency Virus in the Era of Highly Active Antiretroviral Treatment. *Psychosom Med* 2005, 67(6):1013-1021.
  130. Leserman J, Petitto JM, Golden RN, Gaynes BN, Gu HB, Perkins DO, Silva SG, Folds JD, Evans DL: Impact of stressful life events, depression, social support, coping, and cortisol on progression to AIDS. *American Journal of Psychiatry* 2000, 157(8):1221-1228.
  131. Leserman J, Petitto JM, Gu H, Gaynes BN, Barroso J, Golden RN, Perkins DO, Folds JD, Evans DL: Progression to AIDS, a clinical AIDS condition and mortality: psychosocial and physiological predictors. *Psychological Medicine* 2002, 32(6):1059-1073.
  132. Ashton E, Vosvick M, Chesney M, Gore-Felton C, Koopman C, O'Shea K, Maldonado J, Bachmann MH, Israelski D, Flamm J, Spiegel D: Social support and maladaptive coping as predictors of the change in physical health symptoms among persons living with HIV/AIDS. *Aids Patient Care and Stds* 2005, 19(9):587-598.
  133. Parruti G, Manzoli L, Toro PM, D'Amico G, Rotolo S, Graziani V, Schioppa F, Consorte A, Alterio L, Toro GM, Boyle BA: Long-term adherence to first-line highly active antiretroviral therapy in a hospital-based cohort: Predictors and impact on virologic response and relapse. *Aids Patient Care and Stds* 2006, 20(1):48-57.
  134. Blatt SP, Hendrix CW, Butzin CA, Freeman TM, Ward WW, Hensley RE, Melcher GP, Donovan DJ, Boswell RN: Delayed-Type Hypersensitivity Skin Testing Predicts Progression to Aids in Hiv- Infected Patients. *Annals of Internal Medicine* 1993, 119(3):177-184.
  135. Anastos K, Shi Q, French AL, Levine A, Greenblatt RM, Williams C, DeHovitz J, Delapenha R, Hoover DR: Total lymphocyte count, hemoglobin, and delayed-type hypersensitivity as predictors of death and AIDS illness in HIV-1-infected women receiving highly active antiretroviral therapy. *Journal of Acquired Immune Deficiency Syndromes: JAIDS* 2004, 35(4):383-392.
  136. Jones-Lopez EC, Okwera A, Mayanja-Kizza H, Ellner JJ, Mugerwa RD, Whalen CC: Delayed-type hypersensitivity skin test reactivity and survival in HIV-infected patients in Uganda: Should anergy be a criterion to start antiretroviral therapy in low-income countries? *American Journal of Tropical Medicine and Hygiene* 2006, 74(1):154-161.
  137. Lange CG, Lederman MM, Madero JS, Medvik K, Asaad R, Pacheco C, Carranza C, Valdez H: Impact of suppression of viral replication by highly active antiretroviral therapy on immune function and phenotype in chronic HIV-1 infection. *Journal of Acquired Immune Deficiency Syndromes* 2002, 30(1):33-40.
  138. Lederman HM, Williams PL, Wu JW, Evans TG, Cohn SE, McCutchan JA, Koletar SL, Hafner R, Connick E, Valentine FT, McElrath MJ, Roberts NJ, Currier JS: Incomplete immune reconstitution after initiation of highly active antiretroviral therapy in human immunodeficiency virus-infected patients with severe CD4(+) cell depletion. *Journal of Infectious Diseases* 2003, 188(12):1794-1803.
  139. Lange CG, Lederman MM, Medvik K, Asaad R, Wild M, Kalayjian R, Valdez H: Nadir CD4+ T-cell count and numbers of CD28+ CD4+ T-cells predict functional responses to immunizations in chronic HIV-1 infection. *Aids* 2003, 17(14):2015-2023.
  140. WHO: SCALING UP ANTIRETROVIRAL THERAPY IN RESOURCE-LIMITED SETTINGS: TREATMENT GUIDE-LINES FOR A PUBLIC HEALTH APPROACH. Edited by: Hammer S. Geneva, World Health Organisation 3 by 5 Initiative; 2004:1-68.
  141. Costello C, Nelson KE, Suriyanon V, Sennun S, Tovanabutra S, Heilig CM, Shiboski S, Jamieson DJ, Robison V, Rungruenthanakit K, Duerr A: HIV-1 subtype E progression among northern Thai couples: traditional and non-traditional predictors of survival. *Int J Epidemiol* 2005, 34(3):577-584.
  142. Lau B, Gange SJ, Phair JP, Riddler SA, Detels R, Margolick JB: Use of total lymphocyte count and hemoglobin concentration for monitoring progression of HIV infection. *Jaids-Journal of Acquired Immune Deficiency Syndromes* 2005, 39(5):620-625.
  143. Gange SJ, Lau B, Phair J, Riddler SA, Detels R, Margolick JB: Rapid declines in total lymphocyte count and hemoglobin in HIV infection begin at CD4 lymphocyte counts that justify antiretroviral therapy. *Aids* 2003, 17(1):119-+.



144. Florence E, Dreezen C, Schrooten W, Van Esbroeck M, Kestens L, Franssen K, De Roo A, Colebunders R: The role of non-viral load surrogate markers in HIV-positive patient monitoring during antiviral treatment. *International Journal of Std & Aids* 2004, 15(8):538-542.
145. Badri M, Wood R: Usefulness of total lymphocyte count in monitoring highly active antiretroviral therapy in resource-limited settings. *AIDS* 2003, 17(4):541-545.
146. Balakrishnan P, Solomon S, Kumarasamy N, Mayer KH: Low-cost monitoring of HIV-infected individuals on highly active antiretroviral therapy (HAART) in developing countries. *The Indian journal of medical research* 2005, 121(4):345-355.
147. Maas JJ, Dukers N, Krol A, van Ameijden EJC, van Leeuwen R, Roos MTL, de Wolf F, Coutinho RA, Keet IPM: Body mass index course in asymptomatic HIV-infected homosexual men and the predictive value of a decrease of body mass index for progression to AIDS. *Journal of Acquired Immune Deficiency Syndromes and Human Retrovirology* 1998, 19(3):254-259.
148. Castetbon K, Anglaret X, Toure S, Chene G, Ouassa T, Attia A, N'Dri-Yoman T, Malvy D, Salamon R, Dabis F: Prognostic value of cross-sectional anthropometric indices on short-term risk of mortality in human immunodeficiency virus-infected adults in Abidjan, Cote d'Ivoire. *American Journal of Epidemiology* 2001, 154(1):75-84.
149. Thiebaut R, Malvy D, Marimoutou C, Dabis F: Anthropometric indices as predictors of survival in AIDS adults. Aquitaine Cohort, France, 1985-1997. *European Journal of Epidemiology* 2000, 16(7):633-639.
150. Malvy D, Thiebaut R, Marimoutou C, Dabis F: Weight loss and body mass index as predictors of HIV disease progression to AIDS in adults. Aquitaine cohort, France, 1985-1997. *Journal of the American College of Nutrition* 2001, 20(6):609-615.
151. Paton NI, Sangeetha S, Earnest A, Bellamy R: The impact of malnutrition on survival and the CD4 count response in HIV-infected patients starting antiretroviral therapy. *Hiv Medicine* 2006, 7(5):323-330.
152. Mekonnen Y, Dukers N, Sanders E, Dorigo W, Wolday D, Schaap D, Geskus RB, Coutinho RA, Fontanet A: Simple markers for initiating antiretroviral therapy among HIV-infected Ethiopians. *Aids* 2003, 17(6):815-819.
153. Mocroft A, Kirk O, Barton SE, Dietrich M, Proenca R, Colebunders R, Pradier C, D'Arminio Monforte A, Ledergerber B, Lundgren JD, group ESIDA: Anaemia is an independent predictive marker for clinical prognosis in HIV-infected patients from across Europe. *AIDS* 1999, 13(8):943-950.

## NEW PROSPECTS FOR THE THERAPY OF THE PATIENTS WITH DISSEMINATED MAMMARY CARCINOMA

Lokhov R. Ye.

Research Institute of Biochemical Engineering of Cell, Vladikavkaz, Russia

---

We proved 50% antitumorigenic activity of RL-175 preparation in 40 patients with disseminated breast cancer, when modern physical-chemical therapy had failed or when the patients had been rejected treatment in view of their high resistance. In monotherapy RL-175 surpasses cytostatic agents known in literature both itself and in combination with the other agents. The RL-175 effect appears to be mediated by the increase in DNA reparation mechanisms and the activation of genetic mechanisms of apoptosis program, as well as the enhancement of cell genes transcription control.

In oncology the prospects of RL-175 as the means of last hope is accounted for not only dramatic tumor regression, when taken by the patients with advanced breast cancer (50% and more), but also concomitant 90% relief of pain syndrome, extremely low toxicity, and high efficacy in the prophylaxis of this severe disease.

---

### Introduction

It seems that cell malignancy, in human breast, in particular, is caused by multiple factors such as hereditary mutations, damage of different genes BRCA1, BRCA2, mts1, CYP19, polymorphism of steroidogenesis genes and the other damage of genome still unknown [1-4]. For example, the experiment proved an important role of an mts1 truncated gene deprived of a segment of 450 nucleotides in the progress of breast cancer. CYP19 aromataze gene, which is localized on the long arm of the 15<sup>th</sup> chromosome, involves several non-complied variants of exon I into expression. Due to the existence of multiple promoters of CYP19 gene transcription and depending on their disposition across each variant of exon I and II, the structure of the transcript is characterized by the tissue specificity.

However, in spite of considerable progress in molecular-genetic methods of the analysis of nucleotide sequences of DNA and RNA, the exponential growth of data on mutations at the stage of replacement or deletion of nucleotides, the structure of chromosomes and other biological systems, morbidity and mortality rate after breast cancer in the world tends to grow [5,6]. Such situation in oncology has developed due to

the absence of a reliable strategy of search of effective drugs for the treatment of patients with disseminated mammary carcinoma.

By now, capecitabin, docetaxel, doxorubicin, paclitaxel, vinblastin, and other agents have demonstrated the most significant effect (> or = 50%) on the regression of disseminated mammary carcinoma in monotherapy. A large number of cytostatic agents make an impertial effect of less 50% (5-phtoruracilum, cyclophosphamide, metoxantron, methotrexatum, thiophosphamidum, vinblastin, vincristine, chlorbutinum) [7]. The basis of any chemotherapy program for disseminated mammary carcinoma is the combination of cytostatic agents. One of the most effective combinations is docetaxel, 5-phtoruracilum, cyclophosphamide, methotrexatum, doxorubicin, and paclitaxel.

The effect of the above combination of cytostatic agents during the first stage of chemotherapy is 50% and more in patients with disseminated mammary carcinoma. However, only 5 to 10% patients demonstrate total tumor involution. During the third and the later stages of the process the total therapeutic effect (system response) doesn't exceed 10 to 15%. [7] During the later stages the effect of the mentioned cytostatic agents falls to zero level of

the objective response. Patients with remote metastases of  $T_{3-4} N_1 M_0$  and  $T_{3-4} N_1 M_{1-3}$  stages appear to have irreversible morphologic and metabolic changes. This patient population with an early fatal prognosis lacks reliable strategy of both improving survival in general and restoration of acceptable quality of life. For the majority of these patients recurrence therapy is an extremely complicated problem, since their reserves have already been exhausted at the stage of primary treatment.

In this article we submit the results of clinical tests of a new generation anticancer agent RL-175 in 32 volunteers with fatal disseminated breast cancer of  $T_{3-4} N_1 M_0$  and  $T_{3-4} N_1 M_{1-3}$  stages. By the authority of the Ministry of Public Health of Russia № 10-13, October 27, 1991, patients who had previously undergone a complete course of conventional physicochemical therapy, were included in the study. In these patients standard treatment was not only inefficient, but provoked metastasis processes. Eight other patients of different age took part in the drug test. They had breast cancer of stages III and IV detected for the first time and showing quick progress.

#### Patients and Methods

40 hopeless patients of aged 30 to 61 years old (average 38) with disseminated breast cancer underwent treatment with RL-175 within the period of 1988 to 2000. 32 of them had undergone complete courses of up-to-date therapy (surgery, radiation therapy, hormonal therapy and chemotherapy) in different specialized clinics and centers in the USSR and Russia.

The patients were divided into 4 groups depending on the peculiarities of the clinical pattern. Group I included 4 patients aged 30 to 45 years in pre-menopausal period and 4 elderly patients (45 to 61 years) in a deep menopause and breast cancer of stages III and IV detected for the first time and growing progressively worse very quickly. These patients refused to undergo the conventional chemotherapy or gamma-ray teletherapy,

neither mastectomy because of high resistance to the previous treatment. 32 patients with disseminated breast cancer of  $T_{3-4} N_1 M_0$  and  $T_{3-4} N_1 M_{1-3}$  stages took part in the study of groups II-IV. In these patients the conventional radiation, hormonal and chemotherapy turned to be unsuccessful. These groups of patients had metastases found in soft tissues, lymph nodes, and bones, especially thoracic and lumbar vertebrae.

The following factors served as the inclusion criteria: voluntary consent of a patient to sustain treatment, strict verification of the diagnosis, objective assessment of the patient's status, extremely low effectiveness of the conventional cytostatic agents. Also, the ethic norms and claims made to the adaptive immunotherapy of cancer (Rosenberg [8]), as well as the standards worked out by the Helsinki Declaration of 1975 (revised in 1983 and 2000) were taken into account. Patients who died before the end of the complete course of treatment and patients with irreversible associated pathology were excluded from the study.

The objective factors testifying to the beneficial antitumor effect of RL-175 as of the only treatment of the last line of chemotherapy were: a 50% regression of tumor and metastases; an average three-year recurrence-free life span; almost complete relief of pain syndrome; and rehabilitation of subjective and objective parameters and life quality. Before treatment almost all patients had suffered severe or very severe pain (the third step of the analgesic ladder) and for this reason they were given intramuscular injections of opiates (omnophonim, morphini hydrochloridum) 2 to 4 times a day. The life quality was assessed by the relief of pain syndrome, day activity, duration of night sleep and so on.

RL-175 was synthesized by the author of this paper. We conducted the pre-clinical trial of RL-175 at the Oncologic Scientific Center of the Academy of Medical Sciences of Russia (Moscow) and other academic

centers in Russia. Physicochemical and biological properties of the preparation are described in the works by Lokhov [9-13]. The drug showed low carcinogenic and mutagenic activity in experimental models (rats and mice). LD<sub>16</sub> for RL-175 constituted 1200 mg per 100 g of the body weight when introduced per orally.

All the patients were given RL-175 daily per orally in the dose of 20 mg per 2 ml of 30% alcohol for 30 days (the first course). The second course was performed after a five-day interval. The duration of the third course depended on the objective and subjective status of the patient. Anti-tumor effect of RL-175 in groups 1-4 is shown in tables I-IV.

### Results

40 patients with disseminated breast cancer were divided into 4 groups depending on the peculiarities of the clinical course. The protocols of treatment with only RL-175 are shown for each group. The efficacy of the drug in patients with disseminated breast cancer was  $>$  or  $=$  50%.

**Group I.** Patient B (b. 1959) fell ill at the age of 32. Histological and mammographic diagnosis was breast cancer, nodose form of T<sub>3</sub>N<sub>1</sub>M<sub>0</sub> stage. The tumorous focus with radial outline on the mammogram of 20 May 1992 (**Figure 1**) was a centrally located node of homogeneous density of 4.0 x 7.0 cm and of irregular round shape. The metastases were discovered in only one axillary lymph node.

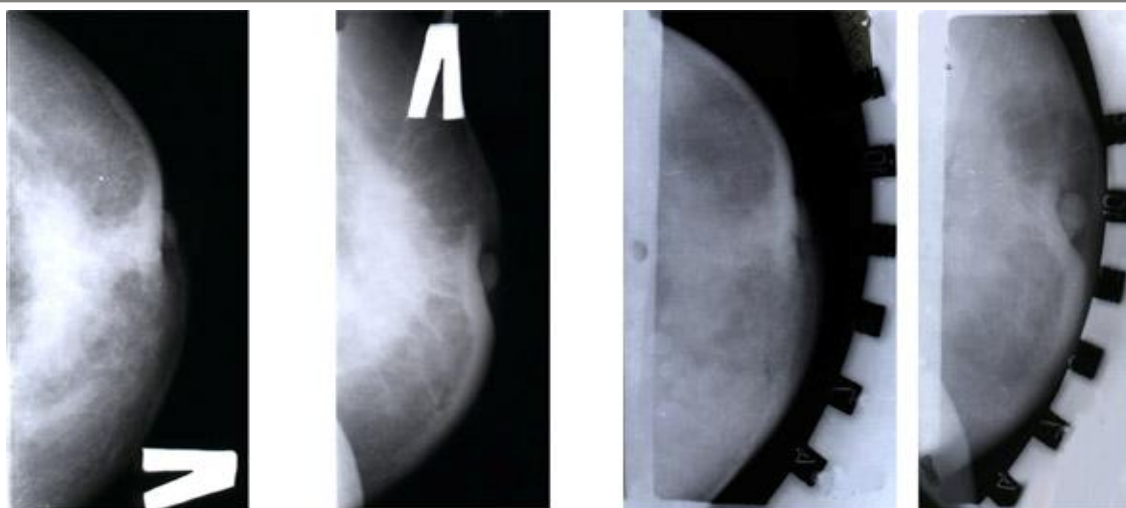

**Figure 1.** Patient B. Mammogram: a centrally located node of homogeneous density of 4.0 x 7.0 cm, irregular round shape, and indistinct outline. In three months tumor regression to 3.0 x 2.0 cm (78.6%) was registered.

This patient refused from chemotherapy, gamma-ray teletherapy, or mastectomy. She only underwent a thirty-day course of monotherapy with a total dose 0.4g of RL-175. The comparison of the mammograms made before treatment on 20 May 1992 and after treatment on 20 Aug 1992 showed that the size of the intensive shadow in the central parts of the tumorous focus with radial outline (due to the skin thickening) decreased to 3.0 x 2.0 cm (>

70%). The individual status of the patient improved considerably. The anesthetic effect predominated in all 8 patients of this group on day 10. As a result, these patients refused from taking non-steroid analgesics. The duration of the night sleep and the day activity increased evidently. The second biopsy №027927 was taken on 18 Sept 1992. Two clusters of epithelial cells with a dramatic fat degeneration proved to reveal

the presence of the complexes of medullar carcinoma.

According to the data of Bernstein et al [4], tumor regression of similar localization has been controlled by glucocorticoids. Hence, the mono-regime effect of RL-175 seems to be affected by age-related changes of sensitivity of adenohipophysis. In fact, 4 elderly patients of this group (45 to 61 years) with a deep menopause did not appear to show any clinical effect even after 3 courses of treatment.

**Group II.** Patient P (b. 1951) was under medical observation at the regional narcological dispensary in Vladivostok from 20 Aug 1993 for disseminated breast cancer of  $T_3N_2M_x$  stage. Histological diagnosis was high-grade differentiated adenocarcinoma with metastases to the thoracic part of spine  $Th_x$ - $Th_{x1}$  and a severe pain syndrome. The patient underwent the courses of gamma-ray teletherapy, combined chemotherapy and hormonal therapy. Radical bilateral ovariectomy was performed on 10 Dec 1993. However, shortly after surgery the patient suddenly worsened and was discharged from the hospital. Supportive therapy was ineffective.

After thorough re-examination, the patient underwent 3 courses of monotherapy with RL-175 (18 Feb to 20 Mar 1994; 12 Jul to 14 Aug 1994; 10 Nov to 10 Dec 1994). In 1995 the patient underwent control check up. Mammography showed that from 8 June 1994 breast tumor decreased by more than 50% (**Figure-2**), infiltration also decreased, whereas fibro-regenerative manifestations increased. Total relief of the pain syndrome was achieved. The patient started leading active life without any limitations. Judging by the subjective and objective parameters, the recurrence-free interval in this patient lasted 4.5 years.

Out of 16 patients of this group, 10 had their recurrence-free interval from 3 to 4.5 years.

**Group III.** Patient S. (b. 1944) was registered at Uman oncological dispensary (Ukraine) on 20 Jan 1989 with the diagnosis of disseminated breast cancer of  $T_2N_2M_1$  stage with the metastases to the thoracic spine  $Th_x$ . Radiography showed that thoracic spine  $Th_x$  was almost completely destroyed. The patient underwent Halsted radical mastectomy on 18 Jul 1989. Then a complete course of combined chemotherapy was carried out. However, after the mastectomy metastatic progress was detected. Severe pains appeared. The patient was bedridden. She had to wear a corset. Severe intoxication developed, and the patient took steroid analgesics. She worsened dramatically and poor outcome was predicted.

The patient underwent only 2 courses of RL-175 (17 Feb to 14 March 1991; 17 March to 12 Apr 1991). During the first course reliable pain relief was marked. After treatment stable radiological remission of more than 60% and partial restoration of bone structure  $Th_x$  and  $Th_{x1}$  were achieved. Active unrestricted life style was also restored. She put off her corset and took up her previous job. The follow-up period was 42 weeks. Insignificant progress of metastatic damage of  $Th_x$  and  $Th_{x1}$  was detected in 12 months (**Figure 3**). Another patient with similar history had a fracture of thoracic  $Th_{x-x1}$  and lumbar  $L_{1-II}$  vertebrae and total loss of mobility.

Patient G-H underwent 2 courses of RL-175. The anesthetic effect became clearly evident on days 10 to 13. She could do some sedentary work and in 1 to 1.5 months walk and do some work about the house. She took off her corset. A recurrence-free period of stable roentgenologic regression of tumor focuses was 42 months. 7 of 12 patients with disseminated breast cancer demonstrated the same interval with 50 to 70% positive results.

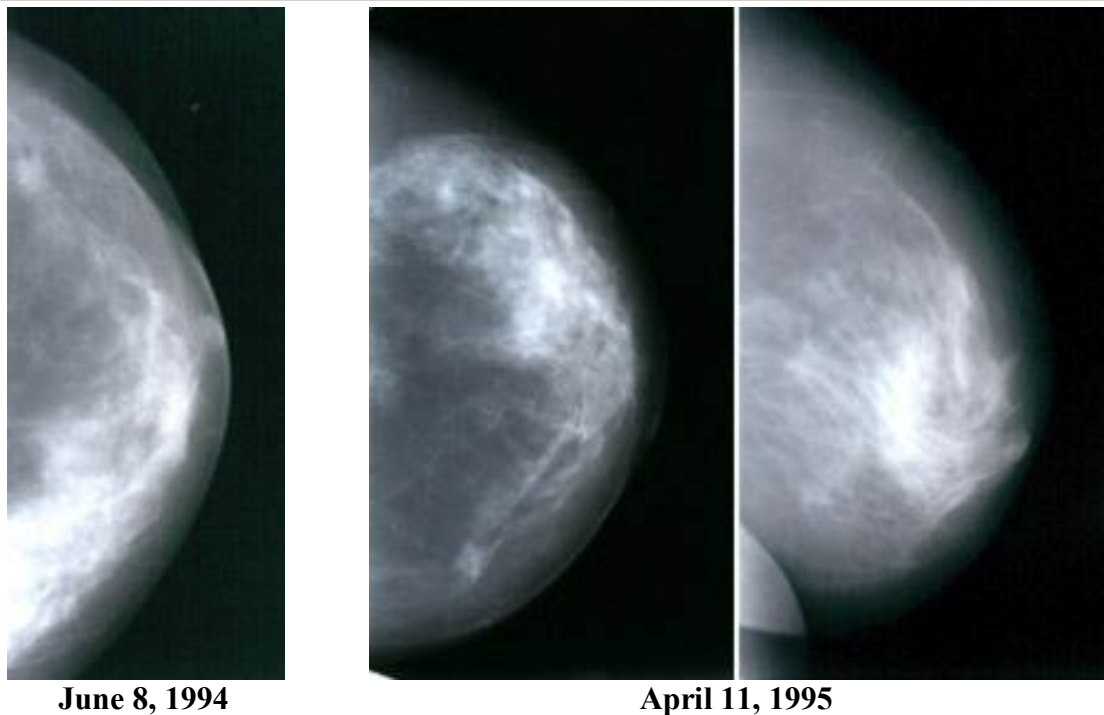

**Figure 2.** Patient P. Mammogram: high-grade differentiated adenocarcinoma with metastases to the thoracic part of spine Th<sub>x</sub>-Th<sub>x1</sub> of irregular radiant form and unclear contour. Tumor regression is more than 50%. Tumor size progress has not been identified within 44 months.

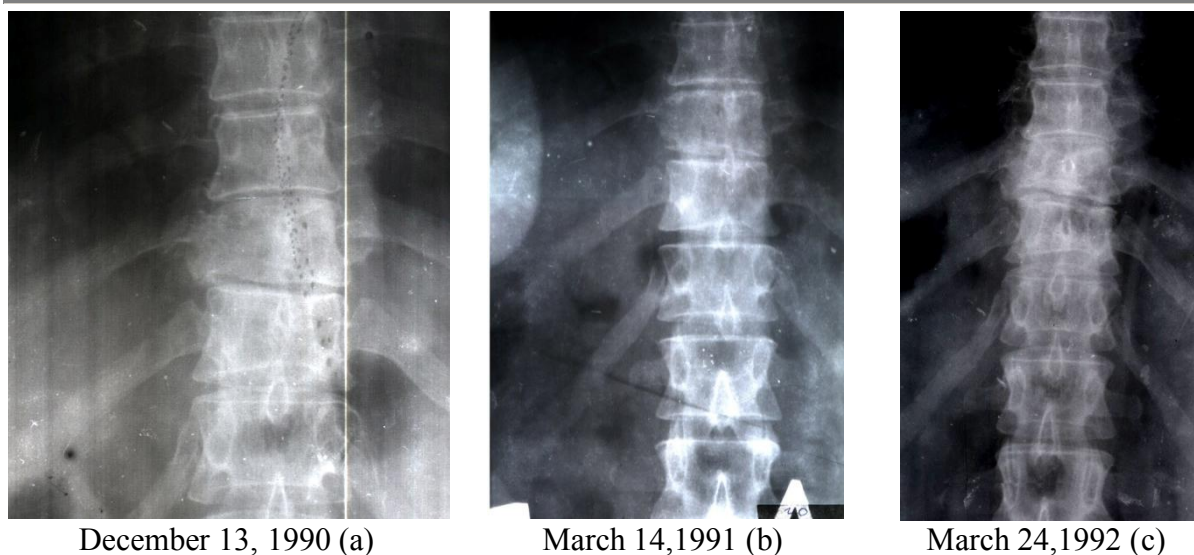
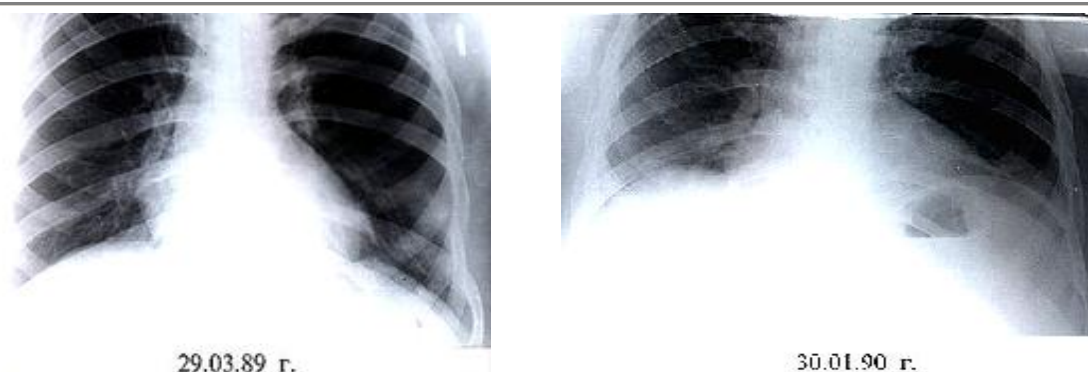

**Figure 3.** Patient S. Roentgenogram of the thoracic spine of 13 Dec 1990 (a). Pathologically almost a compression fracture of vertebrae Th<sub>x</sub> and Th<sub>x1</sub>. Roentgenogram of the same segment of spine in four months (b). Almost total tumor regression is observed. Metastatic lesion of Th<sub>x</sub> and Th<sub>x1</sub> is insignificant 15 months after the first course of treatment, 24 Mar 1992 (c).

**Group IV.** Patient E (47 years) first turned for consultation to Vladikavkaz oncological dispensary in January, 1987. In May, 1987 she underwent Halsted radical mastectomy. In March, 1989 histological and roentgenological evidence of a tumor focus in the right mammary gland was discovered with metastases into lymph nodes and metastatic damage of the 8<sup>th</sup> left rib with its total destruction. Patient E. underwent three RL-175 courses in mono-regime. After the

first course, metastasis stabilization, partial restoration of the affected rib structure (**Figure 4**) and regression of the process in lymph nodes were identified. The patient was under medical supervision at home in the regime of supporting therapy for 38 months. All 4 patients of the group showed reliable pain relief and increase of sleep duration.

Of 4 patients of this group only 2 demonstrated about 50% general improvement after treatment.



**Figure 4.** Patient K. Metastatic lesion of the 8<sup>th</sup> rib on the left with a complete destruction of the back segment is found on the diagnostic chest roentgenogram of 29 Mar 1989. Eight months later bone structure of the affected rib was partly restored along the back axillary line.

### Discussion

We have shown the clinical outcomes in groups I to IV of patients of premenopause age suffering from disseminated breast cancer, in whom the standard treatment had been completely exhausted. Basing on the results given above, we can conclude that RL-175 antitumor activity considerably higher, than that of all the other cytostatic agents and drugs described in literature, both in mono-regime and combined with the other known drugs on all the lines of chemotherapy.

Nowadays, docetaxel of taxan row is considered the most effective preparation for disseminated breast cancer. Numerous randomized investigations in patients with disseminated breast cancer showed that after docetaxel therapy the frequency of objective response (complete and incomplete

regression) as the first line of therapy was more than 60% [7]. Multiple studies performed in 30 oncological centers of the world showed that an objective effect of docetaxel as the chemotherapy of the second line was 41% with median duration of its effect amounting to 6 months [14]. The other taxan, paclitaxel used for chemotherapy of the first line in patients with disseminated breast cancer showed 29% to 62% improvement is from with median duration of positive response of 6 to 8 months [15].

Of the new generation of cytostatic agents vinorelbine (navelbin) of vinkaalkaloids has to be mentioned. Its effect in the first line therapy of disseminated breast cancer reaches 35 to 65% with median duration of 5 to 9 months [16], and in the

second line therapy 20 to 31% with median duration of 4 to 8 months.

New drugs (such as taxans, vinorelbin, kapecitabin) enabled the development of highly efficient combinations. Thus, the combination of docetaxel and doxorubicin in the first line therapy of disseminated breast cancer resulted in about 82% objective response. In the later randomized investigations of the same drug combination the objective response in patients with disseminated breast cancer was higher than 60% and 47% [7]. The combination of doxorubicin and paclitaxel allowed for 94% increase in objective response rate [17].

However, in the third and the later lines of therapy, the percent of clinical effect of the known drug combinations dramatically decreases to 10 to 15%. In comparison, we are demonstrating here that the objective positive effect of RL-175 in mono-regime for disseminated breast cancer increases from zero to 50% and more.

It should be stressed that the known cytostatic agents display considerable hematological toxicity both in mono-regime and in different drug combinations. Moreover, treatment with the above combinations is accompanied by the development of chronic cardiac toxicity in 18% cases. RL-175 is among the powerful anti-anemic factors of blood haemopoiesis regulation [13]. It also significantly influences the regulation of energy homeostasis [9–13].

At the same time, median duration of the objective response for the known cytostatics both in mono-regime and combination as chemotherapy of the first line constitutes 6 to 8 months and on the last line decreases to zero level, whereas our clinical data in groups I to IV of patients with disseminated breast cancer demonstrate this median increase up to 3 years and more. The given comparison by the duration median of the recurrence-free interval of therapy is extremely important for understanding the fact that the known strategy of search for the

drugs with selective antitumor action on specific targets of malignant cells is of low efficacy. We believe that this is due to multivariant transmission of signals for tumorigenic growth into the cell. The new conception of search for highly efficient antitumor agents and methods for treatment of patients with disseminated breast cancer are described below.

ATP concentration in tumorigenic cells near plasma membranes falls to zero, and this is the reason for the damage of the control of complex interaction of regulator proteins (c-myc and p53) which are the factors of transcription. At the same time, a tendency to local synthesis and heterogeneous ATP accumulation in plasma membranes of tumorous cells has been revealed [18]. These locally formed and short-living ATP molecules can activate tyrosine kinases and then through phosphorylation by tyrosine residua, launch the cascade multivariant mechanism of tumor growth by tumorigenic peptides [19].

Our clinical results on tumor regression in patients with disseminated breast cancer can be interpreted from the point of view of inhibition by RL-175 preparation of the mechanisms of perception and transmission of signals of tumorigenic factors of growth into the cell.

On the other hand, the analysis of literature on the influence of different inhibitors of tyrosine kinase receptors on ATP, insulin, and other activation factors reveals a low value of the above mentioned anticarcinogenic conception. Chiefly, it is because the processes of perception and transmission of signals for tumorigenic factors of growth into the cell are miscellaneous, multivariant, and very often depend on a variety of internal and external factors [14].

P53 gene is the sensor of DNA damage and cell cycle disorder. P53 mutation is found in more than a half of the cancers, growing during prolonged chemotherapy [20]. It was shown that in case of P53



activation, the gene protein can initiate the two following independent programs [20]:

- Temporary stoppage of the cell cycle in G<sub>1</sub>S-phase of kariomitotic cycle by means of P21<sup>WAF1</sup> protein inhibiting cyclin-dependent kinases;
- Inhibition of the launch of apoptosis program with the aid of Bax or Bid genes inactivation, proapoptosis genes of Bcl-2 family.

In literature [2, 20] there are also the data on participation of P53 in the processes of DNA reparation through activation of gene P53R2 encoding ribonucleotide reductase. The decrease of gene P53 activity or mutation resulting in the loss of the ability to initiate apoptosis is a serious factor predisposing to tumor formation and the development of resistance to chemotherapy.

Hence, it could be expected that RL, which promotes significant increase in ATP

concentration in plasma membranes of tumorous cells [9-12], must adequately enhance the regulatory mechanisms of P53 genes and Bcl family activity.

In our works [9-13] we showed that compounds encoded RL-175, RL-S, and RL-3 accelerate by 60 to 80% the oxidation of succinate by mitochondria of white rats' liver ( $1.14 \times 10^{-6} \text{ c}^{-1}$ , against  $0.67 \times 10^{-6} \text{ c}^{-1}$  in control animals) ( $p < 0.001$ ). ATP levels in the skeletal and heart muscles of Vistar line white rats treated with the preparation under study was 3 to 4 times higher than the control values. Moreover, genuine free energy ( $\Delta G$ ) of ATP hydrolysis in the muscle cells with ATP, ADP, and Pi concentrations of 40, 9.3, and 8.05 mM, correspondingly, pH 7.0, and 25°C, doesn't exceed  $\Delta G$ , evolved under ATP hydrolysis in the intact rat erythrocytes, muscles, and liver [21, 22].

$$\Delta G = \Delta G^{01} + 2,303 RT \lg \frac{[ADP][P_i]}{[ATP]} = -12,4 \text{ kcal/mole } (-51,9\text{kJ/ mole}),$$

where:  $\Delta G^{01}$  is standard free energy; R is gas constant; T is absolute temperature; Pi is phosphoric acid.

Then, the difference  $\Delta G_1 = \Delta G - \Delta G^{01} = -5,1 \text{ kcal/mole } (-21,3 \text{ kJ/ mole})$  comprises the energy of shift by the investigated compounds of disconnected standard equilibrium constant  $K_{eq}^0 = 1,15 \cdot 10^{-3}$  [22] in the spontaneously connected transformation of A into B in the pool of multi-enzymatic complex of the respiratory chain up to  $10^{10}$  times:

$$K_{eq} = \frac{[B][ADP][P_i]}{[A][ATP]} = 0,28 \cdot 10^7,$$

where  $K_{eq} = \frac{[B]}{[A]} = 5,62 \cdot 10^3$ ; ratio  $\frac{[ADP][P_i]}{[ATP]}$  of order 500 [22].

The given calculation testifies to that under the influence of the compounds under study four, and not three ATP molecules, are synthesized in three key segments of the respiratory chain and standard constant equilibrium ( $K_{eq}$ ) in mitochondria shifts  $10^{40}$  times, significantly exceeding the similar normal process ( $10^{24}$  times) [21, 22].

Along with the known bioenergetic ATP functions (such as movement, active transport, and biosynthetic metabolism), one more function has also been discussed in literature: the amplification of a signal for cell growth and conduction of proliferative stimulus to the nucleus [18, 22]. However, the concentration role of ATP as a mediator of conduction of proliferative stimulus to the

nucleus of a malignant cell, with adequate regulation of gene activity of cell growth factors, has not yet known.

We studied the effect of RL-175, RL-S and RL-175 on the malignant cells of human ovarian carcinoma (CaOγ) [11]. The DNA and RNA synthesis rate, as well as protein synthesis were estimated by the introduction of [<sup>3</sup>H]-thymidine, [<sup>3</sup>H]-uridine and [<sup>3</sup>H]-leucine into these cells. A 50% depression of <sup>3</sup>HT, <sup>3</sup>HU, and <sup>3</sup>Hleu inclusion in the tested concentrations  $0.5 \times 10^{-3}$  mole was taken as a borderline criterion of the drug activity.

The drugs under study almost completely inhibit DNA synthesis and at the same time considerably stimulate RNA synthesis. Thus, under the influence of RL-S in the dose is 10 mcg/ml, the rate of [<sup>3</sup>H]-uridine inclusion increases by 214% compared to the control value. Correspondingly the protein synthesis increases. These results suggest that RL-like agents contribute to the transfer of the malignant cell through the stage of mitosis (G<sub>2</sub>M) to the normal cycle of cell proliferation. In this case, G<sub>2</sub>M > G<sub>1</sub>S ratio can serve as a regulation criterion of P53 and hence, Bcl-2 family gene activity.

We associate the formation of an excessive RNA pool (matrix, ribosomal, informational, and others) with "edited" extension of the RNA information chain via amplification of that segment of the notional DNA chain, which through genes weakening or disconnecting provoked malignant neoplasms of different location [23, 24].

The concept of "edited" amplification (regulation) of gene expression according to the extension of the notable RNA chain, accounts for indisputable stable recurrence-free remission of malignant foci (mounting to > or = 50%) in patients with disseminated breast cancer who had demonstrated the failure of up-to-date physicochemical therapy (operation, radiation, hormonal and chemical therapy). We suggest that RL-175 effect on the malignant cells proves the possibility of its

regulatory role in P53 gene activity, thus launching apoptosis program and inducing the introduction of malignant cells in the normal proliferation and differentiation cycle. Apoptosis launch is an essential factor in overcoming the resistance barrier of the malignant cells to chemical therapy.

Consequently, the concept discussed here can serve as a serious argument in favor of promising perspectives of RL-175 for prophylaxis of this disease rapidly progressing in the world.

#### References:

1. Molecular aspects of cancer and its therapy. In: series "Molecular and cell biology updates" Mackievich A. and Sehgal P.B., (Eds) Basel, Boston, Berlin: Birkhauser, 1998
2. Cell Growth and Oncogenesis. In: series "Molecular and cell biology updates" Bannasch P., Kanduc D., Papa S. and Tuger J.M., (Eds.). Basel, Boston, Berlin: Birkhauser, 1998
3. Hanson K.P., Imyanitov E.N., Oncogene ERBB2/HER2: From molecular to clinical oncology. Problems in oncology (Russia) 48(№2): 137-145, 2002
4. Berstein L.M, Larionov A.A., Pauley R.I. et al: Aromatase gene expression and factors modifying it in breast tumor tissue. Problems in oncology (Russia) 45 (5): 504-510, 1999
5. Cancer statistics review 1973-1989. National Cancer institute NIH Publ. №92-2789, 1992
6. Survival of cancer patients in Europe. The Eurocare study. IARC Sci. Publ. №132, Lyon, 1995
7. Moiseenko V.M., Orlova R.V.: Medicinal treatment of disseminated hormone-dependent tumours. Problems in oncology (Russia) 48 (4-5): 601-614, 2002
8. Rosenberg S.A.: Adaptive immunotherapy of cancer using lymphocyte-activated killer cells and recombinant interleukin-2. In: Devita V.T., Hellman S., Rosenberg S.A. (Eds.). Important Advances in Oncology. Philadelphia, 1986, pp. 55-91
9. Lokhov R.Ye.: New principles of intercellular and intracellular regulation of the organism general homeostasis. Rejuvenation 13(1-2): 14-36, 1985
10. Lokhov R.Ye.: Chemical engineering of cell (expressomorphogenesis) a break-through in contemporary gerontology and geriatrics. In: Recent advances in aging science Beregi E., Gergely J.A., Rajczi K. (Eds.). Bologna (Italy). Monduzzi Editor, 1993, pp.105-107
11. Lokhov R.Ye.: Expressomorphogenesis as new direction of biochemical engineering of

- cell. North Caucasian State Technical University, Stavropol, Russia, 2001. pp 3-92
12. Lokhov R.Ye, Lokhov A.R.: Prospectives of RL-preparation application with the aim of correction of anemia in comparison with recombinant erythropoietin. *The Journal of Hematology* 1(1): 1540-1548, 2003
  13. Lokhov R.Ye.:  $\pi$ -deficient heterosystems influence on ATP synthesis in mitochondria. *Problems of medical chemistry* 1: 64-676, 1986
  14. Radvin P.: Treatment of patients resistant to antracycline therapy. *Anti-Cancer Drugs* 7(Suppl.2):13-16,1996
  15. Moiseenko V.M., Orlova R.V.: The effectiveness of the contemporary chemotherapy in case of metastatic breast cancer of the patients resistant to anthracyclines. *The Problems of Oncology* № 4: 445-447, 1999
  16. Weber B., Vogel C., Jones S. et al: Intravenous Vinorelbine, a first-line and second-line therapy in advanced breast cancer. *J.Clin.Oncol.* 13: 2722-2730, 1995
  17. Sledge G., Neuberg D., Ingle D.: Phase III of dextrorubicin vs paclitaxel vs paclitaxel+doxorubicin as first-line therapy for metastatic breast cancer: an intergroup trial. *Proc. ASCO*, 16: 1999, Abstr.2.
  18. Perevodtchikova N.E., *New trends in breast cancer therapy*. Moscow, 1998.
  19. Karelin A.A., Demidova V.S., Globa A.G. et al: Influence of some growth factors and cytokines on ATP synthesis with plasma membrane-enriched particles isolated from different human tumors. *The bulletin of Russian Academy of medical sciences* 5:21-26, 2000
  20. Xiong Y., Hannon G. et.al: P21 is a universal inhibitor of cycline rinases. *Nature* 366: 701-704, 1993
  21. Lehninger A.L.: *Principles of biochemistry*, Worth Publishers, Inc.. 1982
  22. Stryer L. *Biochemistry*, Freeman W.H. and company, 4-th. New York, 1995
  23. Lokhov R.Ye. Blocking of the genetic mechanisms brain aging and displacement of a life span up to 200-300 years. Poster Presenter The 11-th International congress in Chicago, United States, August 17-22 2003, International Psychogeriatrics Publishers, Chicago 15, №4, p.345
  24. Lokhov R.Ye., Basiev Z.G., Lokhov A.R.: Survivability gene promotion as manifestation of the near victory over the cancer of various location. Theses of the report at the conference "Topical problems of regional phthisiotherapy and pulmonology" Naltchik (Russia), November 13-14 2003, University Press, 2003, pp. 60-62

## AGE-DEPENDENT INDUCTION OF IMMUNITY AND SUBSEQUENT SURVIVAL COSTS IN MALES AND FEMALES OF A TEMPERATE DAMSELFLY

Robb T. <sup>1</sup>, Forbes M. R. <sup>2</sup>

<sup>1</sup>Department of Ecology & Evolutionary Biology, 25 Willcocks Street,  
University of Toronto, Toronto, Ontario, M5S 3B2, Canada

<sup>2</sup>Department of Biology, 209 Nesbitt Building, Carleton University, Ottawa,  
Ontario, K1S 5B6, Canada

To understand variation in resistance to parasites within host populations, researchers have examined conditions under which immunity is induced and/or is costly. Both host sex and age have been found to influence immune expression and subsequently are likely factors influencing the costs of resistance. The purpose of this study was to examine immune expression and associated survival costs for two age groups (newly emerged and sexually mature individuals) of the damselfly, *Enallagma boreale* Selys. Survival was assessed for experimentally challenged and control damselflies, housed initially at 22°C and then subjected to low temperatures (15°C) associated with reduced foraging activity and food deprivation. Experimental conditions emulated natural local variation in bouts of good weather followed by inclement weather (successions of days with hourly mean temperatures around 15°C and/or rainy weather).

At least one of three immune traits was induced to higher levels for both newly emerged and mature *E. boreale* challenged by Lippopolysaccharide (LPS) relative to saline-injected controls, when housed at 22°C. The immune traits assayed included haemocyte concentration, Phenoloxidase activity and antibacterial activity and their induction varied among ages and between males and females. For matures, those injected with LPS had lowered survivorship compared to saline-injected controls that were housed initially at 22°C and subsequently at 15°C. Newly emerged LPS-injected damselflies did not show reduced survivorship relative to newly-emerged controls, despite showing immune induction.

Reduced longevity following induction of immunity was observed for reproductively mature damselflies, but not for newly emerged damselflies. Costs of resistance depend only partly on the immune trait induced and more on the age (but not sex) of the host. In four years, we often observed bouts of inclement weather following good days and these bouts occurred primarily during the emergence periods, but also during the flight periods, of *E. boreale*. The duration of these bouts appear sufficient to compromise survival of mature damselflies that responded immunologically to LPS challenge. We further suggest the environmental conditions likely experienced by different ages of damselflies, following resistance expression, has influenced optimal immune investment by individuals in different age classes and the likelihood of detecting costs of resistance.

### Background

In natural populations, many species are host to one or more parasite species, where parasites are broadly defined to include viruses and bacteria. However, not all parasitic organisms elicit an immune response from individuals of a given host species [1, 2]. Additionally, immune responses and the degree of resistance often vary among hosts, even when the same species of parasite is monitored in observational studies or used in experimental challenges [3-5]. Research has now focused

on both the intrinsic and extrinsic factors that account for this variation in immune responses among hosts and the consequences of resistance to both host and parasite individuals and populations [5- 7].

Evolutionary ecologists have adopted various approaches in attempting to explain within-population variation in immune responses and resistance expression. For example, researchers have examined the extent to which resistance is heritable and whether host responses are specific to the parasite strains used [8,9]. Other researchers

have viewed the fitness benefits of immune defence as being traded off against other traits; an approach used in testing predictions of life-history theory [ 7 , 10]. Importantly, costs of resistance can include intrinsic costs of maintaining immune components in anticipation of parasitism and/or costs of induction i.e., initiating and activating an immune response. It is the latter costs that often are demonstrated for vertebrates and invertebrates in response to challenges from parasites or surrogates of parasitism (for invertebrates, insertion of a nylon filament or injection of Lipopolysaccharides in solution) [11,12].

The costs of resistance are expected to be context dependent, a problem only recently identified [13]. One study to examine context dependent resistance found that starved and immune challenged bumblebee workers had lower survivorship than either fed and challenged workers or starved workers that were not challenged [14]. That study and more recent work [15] has underscored the fact that success of parasites and their impact on their hosts, also should relate to environmentally relevant external factors.

Under natural conditions, insects are subjected to hours or days when foraging is restricted as a result of variable or inclement weather conditions. Hosts less able to acquire dietary resources may subsequently mount a less effective immune response [16,17]. Temperature also can play a key role in host response to parasitism [5]. Yet, little is known of the costs of resistance when temperatures, under which resistance is expressed, are not maintained. We expect when weather conditions are 'good' (resources are not limiting and temperatures are optimal) insects resist parasites. However, what happens if those insects are subjected to 'poor' conditions after allocating resources to resistance? Resistance costs may not be realised unless the host expressing resistance is subsequently challenged environmentally; further, these costs also

may depend on the type of immunity induced and the magnitude of induction.

There have been several studies examining insect immunity; however, patterns of how insects respond to immune challenges are inconsistent and often relate to the immune traits assayed [18-22]. As a primary component of invertebrate immunity, circulating haemocytes are involved in recognition, phagocytosis and encapsulation of invading parasites and pathogens [23,24]. Activation of the pro-Phenoloxidase cascade to produce melanin is a key component of the invertebrate immune system (the production of melanin has both cytotoxic effects and antimicrobial properties [ 25]). In addition, anti-microbial peptides can be produced in response to an immune insult [ 25].

The main purpose of this study was to examine a direct fitness cost in relation to induction of an immune response(s) for adults of the temperate and early-emerging damselfly, *Enallagma boreale* Selys. To ensure our experiment included environmentally relevant conditions

(e.g. periods of 'good' weather followed by successions of days of 'poor' weather), we first assessed the local variation in temperature and rainfall during the emergence and flight period of *E. boreale* for four previous emergence and flight periods (2001–2004). Both low temperatures and periods of heavy rainfall prevent foraging attempts for damselflies under natural conditions and were therefore considered 'poor' weather conditions [26]. Damselflies were immune challenged with a dose of immunogenic Lipopolysaccharide (LPS) in saline solution and allowed to respond at an environmentally relevant 'good' temperature. LPS or bacterial cell wall components are known to induce an immune response in several other insects with out the pathogenic effect of the bacteria (e.g. [14]). To ensure LPS induced an immune response in *E. boreale*, we assessed immune traits of a subsample of LPS-injected and control

(saline-injected) *E. boreale*. We assayed three key aspects of insect immunity: haemocyte concentration, Phenoloxidase (PO) activity and antibacterial activity. Our expectation was that at least one of these immune responses would be induced to higher levels when *E. bore-ale* were immune challenged. The remaining challenged damselflies were subsequently subjected to an environmentally relevant 'poor' temperature and food deprivation. To examine if costs of immune induction were realised when a responding individual is subsequently subjected to 'poor' environmental conditions, survivorship was assessed at cooler temperatures. Reduced adult longevity was expected at cooler temperatures and was expected to relate to the level of immune induction.

Sex differences in immunity are present, and can be understood by reference to natural or sexual selection on the sexes [10,27]. However, there is currently no general pattern of sex differences in immune investment by insects, as has been suggested for mammals [28]. Notwithstanding, host sex is an important factor to consider when assaying immune responses and the ultimate or evolutionary cost of resistance in anticipation of parasitism [29]. As with many insect species, male and female damselflies differ in life-history strategies: males appear to forage to obtain enough resources for mating activity whereas females forage to obtain greater resources for egg production and thereby gain weight during maturity [30]. Of course, the more important question is whether fitness relations to longevity differ for males or females leading to the expectation of higher immunity and longevity in either sex.

Costs of resistance and/or induction of immune defence also are expected to relate to the age of the host. Damselflies have two distinct adult stages, newly emerged (within 24 h of emergence) and reproductively mature [31]. Newly emerged damselflies must allocate resources to cuticular

hardening as well as contend with parasites and pathogens. Enzyme pathways used in the production of melanin for immune defence are similar to those used in cuticular hardening [23,32]. Thus optimal investment in immunity may be limited by the maturation process. Further, based on observations from four previous years, newly emerged damselflies are expected to experience frequent and longer bouts of inclement weather (see methods). In comparison, reproductively mature adults have to contend with costs of reproduction as well as costs of defence if responding to challenge by parasites and/or pathogens. However, mature adults are expected to be most active later in the season when weather conditions should be more favourable (see methods). For another damselfly *Lestes viridis*, differences in immune parameters between newly emerged and mature damselflies were found and explained as age-related differences in life-history trade-offs [33]. The cost of immune induction also may be age-dependent reflecting the optimal patterns of energy allocation during maturation. For example, sex differences in immunity were evident for mature *Scathophaga stercaria* flies; however, this sex difference was not found for newly emerged flies [34]. This inconsistency between mature and newly emerged flies was explained as a result of sex-specific physiological requirements that were age-dependent.

As part of our main objective, we specifically compared *E. boreale* males and females of newly emerged and reproductively mature adults as we suspected both age and the sex would influence the type and magnitude of immune expression and subsequent costs of immune induction. Multiple measures of immunity ensured identification of differences in the specific immune trait expressed between males and females within each age category. Survivorship, as a measure of cost of resistance mediated by immune induction,

was assessed for control and experimental individuals, which were either newly emerged or reproductively mature males or females.

### Results

#### Immune Parameters

Immune parameters were not correlated for newly emerged ( $r$  ranged from 0.02–0.35,  $p$  values ranged from 0.10–0.92) or mature adults ( $r$  ranged from 0.008–0.35,  $p$  values ranged from 0.08–0.94) therefore each dependent variable was analyzed separately.

Haemocyte concentration (cells/0.2  $\mu$ l) did not differ between treatments or between sexes of newly emerged *E. boreale* (Figure 1a; sex  $F_{1,21} = 2.77$ ,  $p = 0.11$ , treatment  $F_{1,21} = 1.07$ ,  $p = 0.31$ , interaction  $F_{1,20} = 0.36$ ,  $p = 0.55$ ). However, both newly emerged males and females did have a higher melanisation index (MI; our measure of PO activity as detailed in the methods) when injected with LPS versus saline (Figure 2a; sex  $F_{1,22} = 1.59$ ,  $p = 0.22$ , treatment  $F_{1,22} = 4.21$ ,  $p = 0.05$ , interaction  $F_{1,21} = 0.16$ ,  $p = 0.70$ ). To assess antibacterial activity, several plates were seeded with bacteria (see methods). Controlling for the variability in bacterial growth between plates, there was a sex-by-treatment interaction when comparing antibacterial activity of LPS and saline injected newly emerged males and females (sex  $F_{1,1} = 352.83$ ,  $p = 0.03$ , treatment  $F_{1,1} = 0.002$ ,  $p = 0.97$ , interaction  $F_{1,1} = 4984.91$ ,  $p = 0.009$ ). Females and not males injected with LPS had heightened antibacterial activity (Figure 3a).

Mature males and females injected with LPS did have a greater haemocyte concentration than saline injected conspecifics (Figure 1b; sex  $F_{1,57} = 1.64$ ,  $p = 0.21$ , treatment  $F_{1,57} = 24.07$ ,  $p < 0.001$ , interaction  $F_{1,56} = 1.62$ ,  $p = 0.21$ ). The MI for both saline and LPS injected mature females was significantly greater than conspecific males, but there was no treatment effect (Figure 2b; sex  $F_{1,54} = 4.09$ ,  $p = 0.04$ , treatment  $F_{1,54} = 1.03$ ,  $p = 0.32$ , interaction  $F_{1,53} = 2.08$ ,  $p = 0.16$ ). Mature females had

a stronger antibacterial activity than males when control for the variability between bacterial plates (Figure 3b;  $F_{1,8} = 5.15$ ,  $p = 0.05$ ). No difference in antibacterial activity between the treatments was observed for mature damselflies (Figure 3b;  $F_{1,8} = 0.09$ ,  $p = 0.78$ , interaction  $F_{1,8} = 2.41$ ,  $p = 0.16$ ).

#### Survivorship

Newly emerged adult *E. boreale* injected with LPS did not have a significantly lower survivorship than conspecifics injected with saline (Figure 4a; ANOVA  $F_{1,88} = 0.72$ ,  $p = 0.40$ ). However, newly emerged females did survive longer than males in both treatments (Figure 4a;  $F_{1,88} = 3.95$ ,  $p = 0.05$ , interaction  $F_{1,88} = 0.62$ ,  $p = 0.43$ ). Survivorship of mature *E. boreale* was lower in the LPS treatment compared to saline injected conspecifics (Figure 4b; ANOVA  $F_{1,117} = 5.81$ ,  $p = 0.02$ ). Similar to the newly emerged *E. boreale*, mature females lived longer than conspecific males in both treatments; however, the result only approached significance (Figure 4b;  $F_{1,117} = 3.54$ ,  $p = 0.06$ , interaction  $F_{1,117} = 0.04$ ,  $p = 0.83$ ).

#### Discussion

A cost of immune induction in terms of adult longevity was evident for immune challenged mature *E. boreale* when subjected to low temperatures and food deprivation. There was approximately 25% reduction in adult survival (from on average 3.88 d to 2.94 d) when immune challenged damselflies were compared to saline injected controls. Two other studies have found similar results where upon activation of the immune system with LPS in adult bumblebees [14] and male field crickets [35], survivorship was lowered. Fellowes et al. [36] also found that larval *Drosophila* had a reduced competitive ability that likely leads to reduced survivorship when resistance was selected. Costs are not limited to just this specific immune challenge (LPS) and immune expression; upon induction of cellular encapsulation of a foreign body, *Tenebrio molitor* females had lowered survivorship

compared to control females [37]. Our results suggest that under natural conditions, mature damselflies would pay the cost of resistance when faced with subsequently poor weather conditions. For this particular *E. boreale* population, there are many occasions when bouts of poor weather follow good weather (Figure 5), but these were more restricted to emergence periods. Importantly, resistance against parasitic mites (one of the most prevalent parasitic associations with adult

Odonata [31]), when initiated, occurs at damselfly emergence [38]. In comparison, mature *E. boreale*, similar to other damselflies, ingest parasitic gregarines when feeding [39]. Although it is still unclear how or if damselflies respond to gregarines in the gut, our data suggest that future research should investigate whether mature damselflies responding to gregarines have lowered survivorship, when faced with inclement weather.

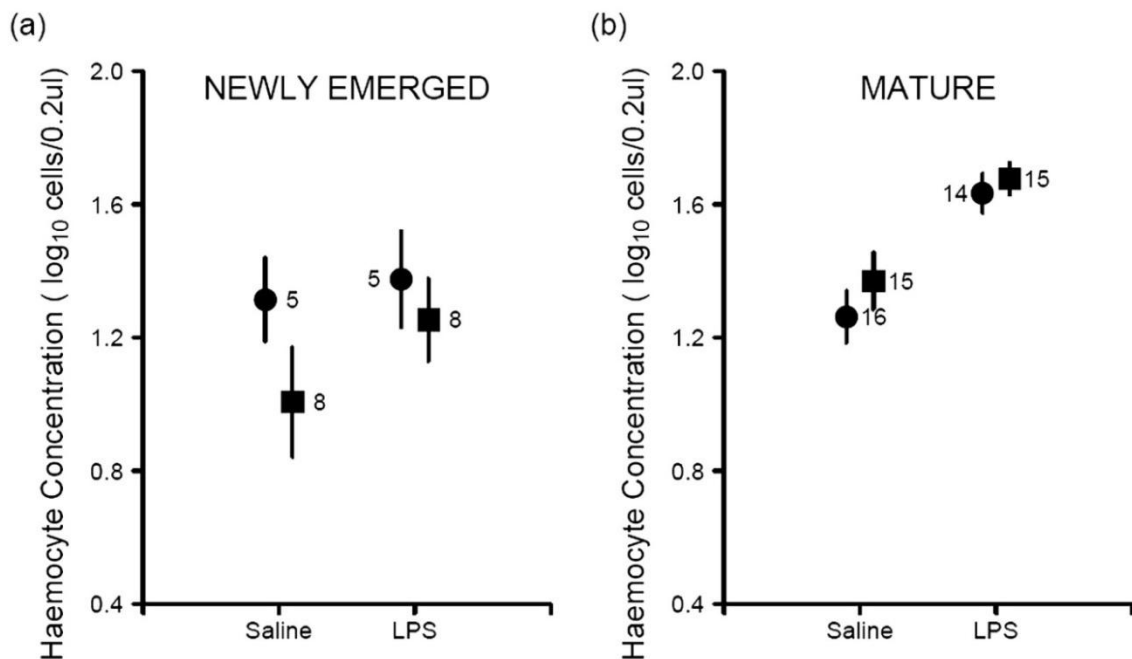
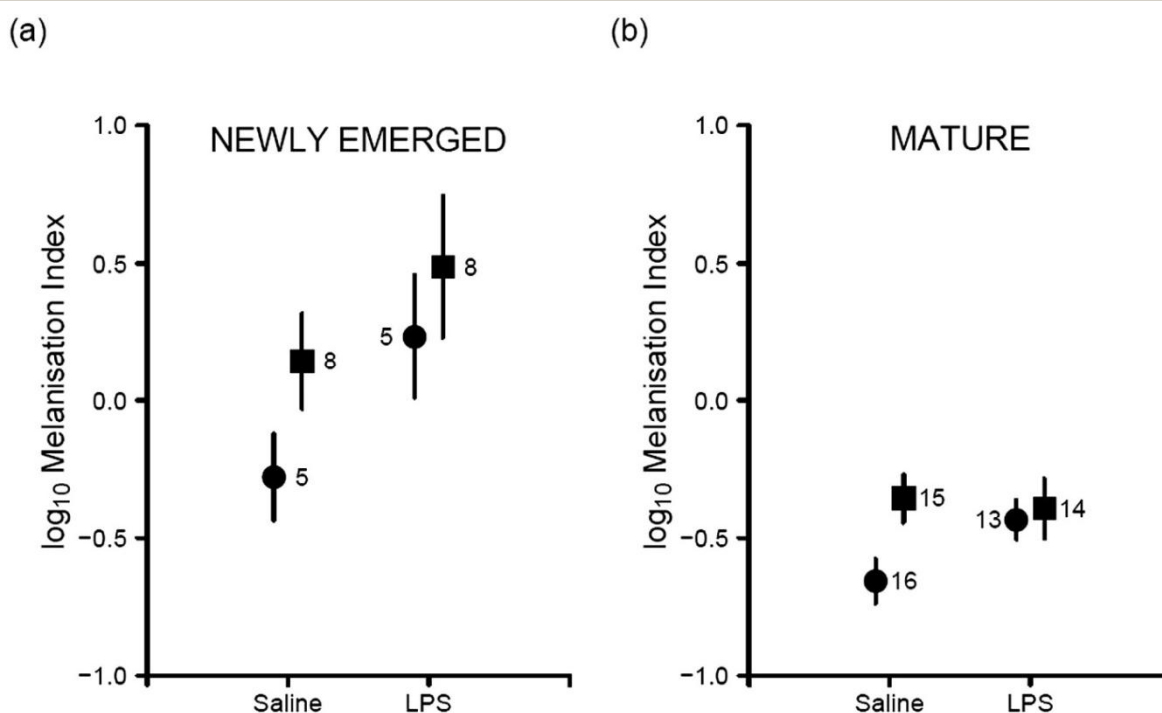

**Figure 1** Mean haemocyte concentration ( $\pm 1$  SE) for males (circle) and females (square) of (a) newly emerged and (b) mature *Enallagma boreale* 12 h after injection of saline or LPS and held at 22°C. Numbers indicate sample size.

One question of interest is why survival of challenged newly emerged *E. boreale* was not significantly lower when compared to unchallenged controls. There is still some debate as to whether costs of resistance should occur, despite evidence in recent studies of trade-offs against other traits such as competitive ability or maturation rate [see [12,40]]. One explanation for our lack of finding a cost in newly-emerged adults is that newly emerged damselflies must contend with parasitic water mites in addition to repairing wounds inflicted by mites piercing the cuticle

(melanin is often observed at the attachment of each mite; T. Robb personal observation). Secondary infection at the mite attachment points also may occur. For other insect hosts, risk of exposure as well as the type of challenge an individual is exposed to has explained how investment into immunity is optimised and subsequently how costs of resistance are minimised [41,42]. It is expected that newly emerged *E. boreale* with a high risk of parasitism have allocated more resources to potential immune responses than have mature reproductive *E. boreale*.





**Figure 2.** Mean melanisation index ( $\pm 1$  SE) for males (circle) and females (square) of (a) newly emerged and (b) mature *Enallagma boreale* 12 h after injection of saline or LPS and held at 22°C. Melanisation index values provide an indication of Phenoloxidase (PO) activity i.e. higher values indicates higher PO activity. Numbers indicate sample size.

Another explanation concerns the nature of the cost of resistance. At emergence, damselflies must invest in cuticular hardening, a process that uses the same enzyme pathways (i.e. proPO cascade) as the production of melanin used in immune defence [23,32]. Thus, a more likely cost of resistance or in repairing wounds for newly emerged damselflies is longer times for cuticular hardening after eclosion. It is also important that newly emerged *E. boreale* responded to the immune challenge by increasing levels of PO activity and females responded with an increase in antibacterial activity; however, mature individuals responded to the LPS challenge with a significant increase in haemocyte concentration (Table 1). This difference in immune activation also may be partially responsible for our inability to find a cost of immune induction under environmentally relevant conditions for newly-emerged damselflies.

Newly emerged damselflies also are more likely to encounter poor weather conditions, in particular for long periods of time in this study population (Figure 5). Responding to parasitism on good days does not appear to represent a cost for newly emerged *E. boreale* when inclement weather follows. In fact, under low temperature and reduced foraging conditions newly emerged

*E. boreale* could live up to ten days at 15°C despite responding to an immune challenge (typical Zygoptera lifespan is up to 23 d [31]).

Both newly emerged and mature females did live longer than males in both treatment groups. A larger body size (particularly mass) could explain the greater female survivorship compared to male conspecifics for both newly emerged and mature *E. boreale*. For mature females, egg resorption also might occur to maintain longevity following resistance expression [43]. In comparison, immune challenged

reproductive female *Tenebrio molitor* beetles suffered reduced longevity while maintaining fecundity [ 37 ]. It is expected that clutch size is less important to reproductive success of

female damselflies than is the number of clutches over her lifetime [44] – this may not be the case for *T. molitor* females.

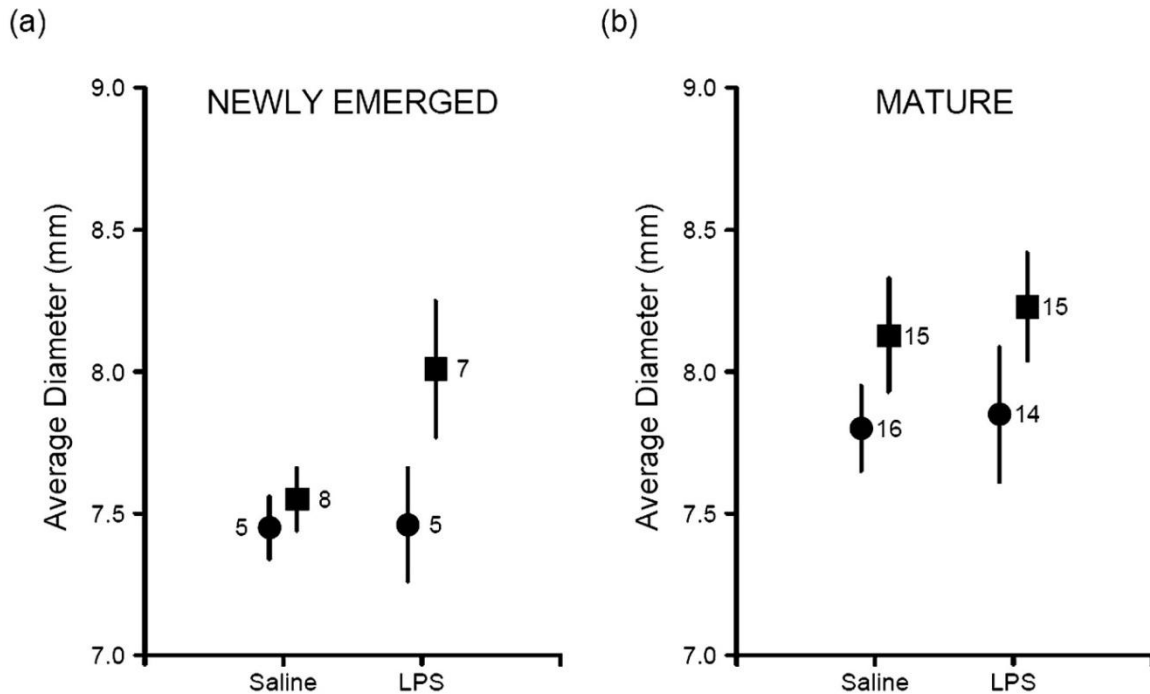
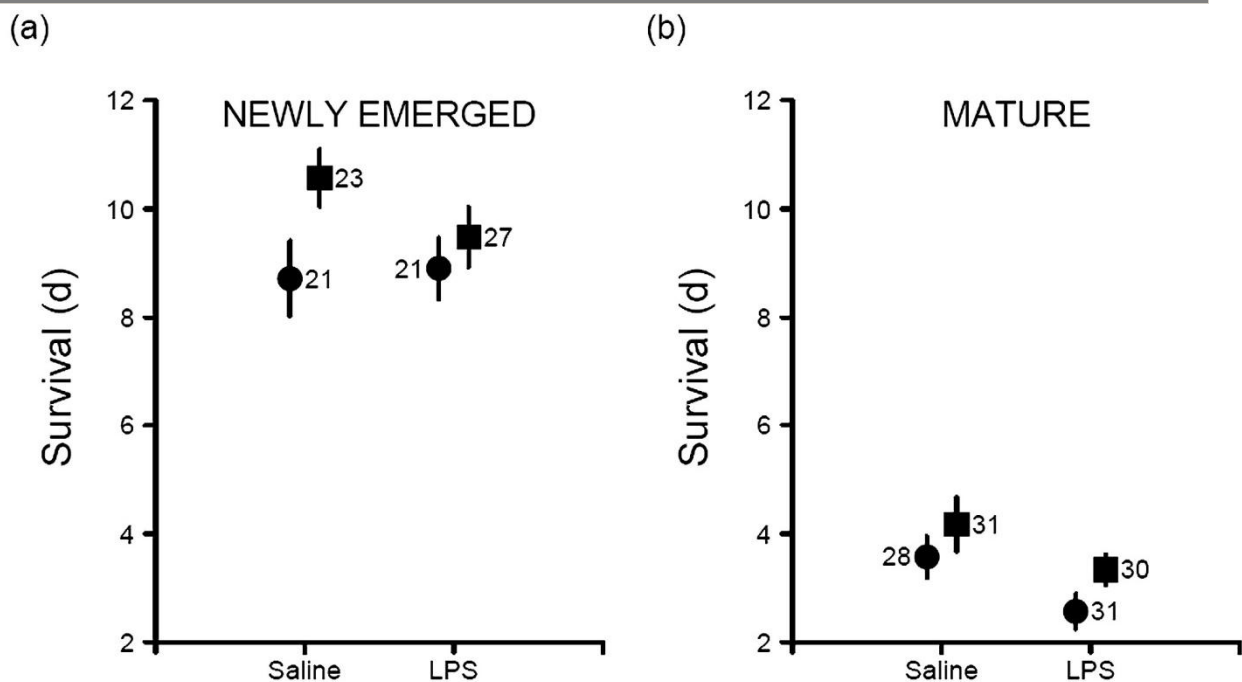

**Figure 3.** Mean average diameter of zones of antibacterial inhibition ( $\pm 1$  SE) for males (circle) and females (square) of (a) newly emerged and (b) mature *Enallagma boreale* 12 h after injection of saline or LPS and held at 22°C. Numbers indicate sample size

Sex differences in immune measures were evident where mature females had significantly greater levels of PO activity when challenged or not challenged compared to conspecific males. Both haemocytes and PO are involved in sclerotization or tanning of egg coverings (involved in the egg viability) in invertebrates [45,46]. Thus, heightened immune traits such as haemolymph PO activity in females may not be indicative of greater immunity, but rather a side-effect of a greater need for melanin. Differences in antibacterial activity were observed between the newly emerged sexes only in response to the immune challenge. However, no sex differences were observed between newly emerged *E. boreale* in our measures of PO activity or haemocyte concentration. Our results were similar to that found for the non-territorial damselfly,

*Lestes viridis*, where newly emerged and mature damselflies demonstrated no difference in haemocyte totals, but where only PO activity was higher in mature females than conspecific males [33].

We did not find any evidence to suggest the cost of immune induction differed between males and females. This is a surprising result as previous work has indicated female immune investment is often greater than male investment [19,21,33,47]. Several hypotheses have been proposed to predict invertebrate sex differences in investment into immunity. Females are expected to invest in egg production whereas males must compete to fertilize eggs. Further, Rolff [48] suggested that assuming greater longevity will increase lifetime egg production; females will invest more into immunity compared to conspecific males.



**Figure 4.** Mean days ( $\pm 1$  SE) survived for males (circle) and females (square) of (a) newly emerged and (b) mature *Enallagma boreale* after injection of either saline or LPS and held at 15°C after an initial 24 h at 22°C to allow response to LPS. Numbers indicate sample size.

Alternatively, males downregulate or suppress immunity as a result of costly secondary sex ornaments and behaviour [ 49, 50 ]. Recently, Mckean & Nunney [15] have suggested that sex differences in investment in resistance arise from male and female differential response to the environment: a topic of considerable relevance to the present study. They suggest the cost of resistance will depend not only on the investment in reproduction but will also relate to variation in fitness-limiting resource availability. Our data suggests that while allocation to immune parameters differed between mature males and females, there were no detectable differences in the costs of immune induction (survival) despite being subjected to similarly poor conditions (Table 1).

**Conclusion**

The results suggest that costs of immune induction do not depend just on the type and magnitude of investment in immunity. We found that costs of immune induction in terms of longevity were evident

for mature damselflies but not for newly emerged damselflies. The variation in weather conditions normally experienced by different aged individuals in this temperate damselfly, the type of immune expression, and when resistance against parasitism is typically mounted, are likely explanations for the age related differences in relation to experimental challenges that we observed. It is important that the environmental relevance of laboratory conditions are well founded for future studies on costs of immune induction in the laboratory.

**Methods**

**Environmental Relevance**

An important aspect of this study was to ensure that our methods of testing for costs of immune induction were environmentally relevant. A standard Stevenson screen at 1.5 m height with a Campbell Scientific 21X datalogger was operational near our collection site (Queen's University Biological Station) and was used to obtain temperature data.

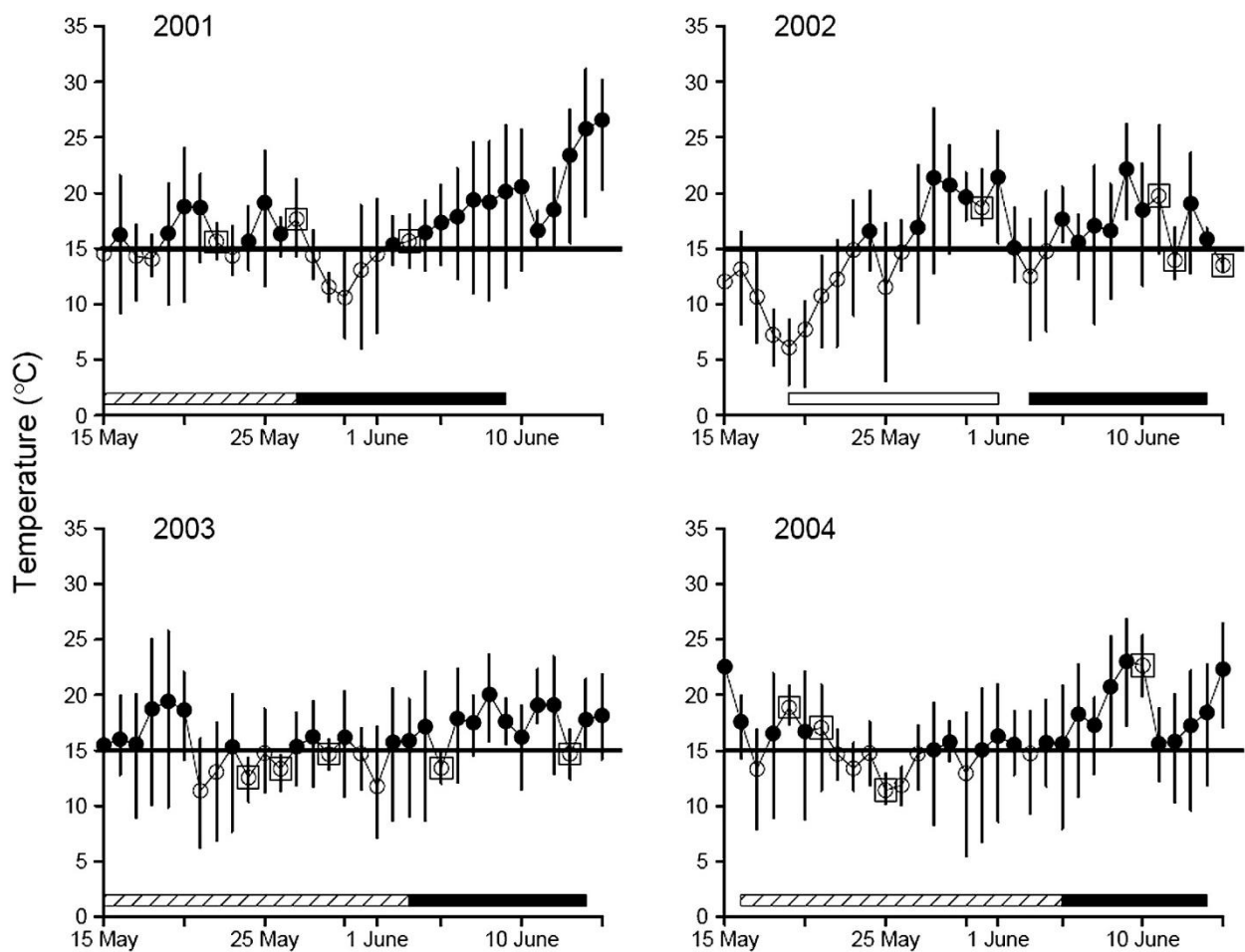

**Figure 5.** Mean hourly temperatures ( $\pm$  maximum and minimum temperatures for the foraging period 0400 h to 1900 h) during the emergence and approximate flight period of *Enallagma boreale* for the years 2001–2004 at Jack's Marsh. Closed circles represent good days of weather while open symbols represent poor weather. Bouts of poor weather were considered to be at least two consecutive days of poor weather. The line marked at 15°C indicates the cut off for our measure of poor weather and open squares indicate days with > 5 mm of rain, also indicating poor weather. The open bar represents the period of time when newly emerged individuals were observed and/or collected at Jack's Marsh. Open bar with hatch marks represents an estimated period of time when newly emerged individuals would likely have been observed at Jack's Marsh (reproductive maturity takes approximately 10–12 d to occur). The closed bar represents the period of time when mature adults were collected at Jack's Marsh.

Temperature was recorded at five-second intervals, allowing us to examine mean hourly temperatures from 0400 h to 1900 h (representing sunrise to sunset or possible foraging times of *E. boreale* in our study region, cf. [ 51 ]). Mean hourly temperatures for each day were examined during the emergence period of teneral as

well as flight period of mature adults (approximately 15 May–15 June) for the four previous years (2001–2004) to the study. We assessed daily grand means of the mean hourly temperatures for each day over the emergence and flight periods of *E. boreale* in the study area (Figure 5). We also assessed rainfall during the daylight foraging times of

*E. boreale*. Poor weather days were determined as the daily mean temperature less than or equal to 15°C and/or when greater than 5 mm of rain occurred indicating heavy rainfall and preventing periods of foraging.

**Table 1.** A summary of the significant results from the immune trait assays and the survivorship experiment. See text and Figures 1–4 for exact values and statistical tests.

	Result	
	Newly Emerged	Mature
Immune trait assayed		
Haemocyte concentration	NS	LPS > saline
MI	LPS > saline	females > males
Antibacterial activity	LPS > saline <sup>1</sup>	females > males
Survival	females > males	LPS < saline females > males <sup>2</sup>

<sup>1</sup>Sex by treatment interaction only females showed induction of antibacterial activity with LPS injection.  $2p = 0.06$

We were interested in bouts of two or more successive days where daily grand mean temperatures were 15°C or lower and/or were characterized by heavy rainfall. We found 11 such bouts (the median duration was 3 d; interquartile range was 2–9 d). These bouts can be seen by examining Figure 5. Six of those bouts were during the emergence periods of *E. boreale* whilst three bouts were during the flight periods and the remaining two bouts bracketed the emergence and flight periods. The mean daily temperature on the days preceding each of the bouts ranged from 16–22°C (for the ten bouts where temperatures were recorded on the day previous). The maximum daily temperature during the daylight foraging times for those days ranged from 18–26°C. Based on these data, we chose 22°C to house LPS-injected and saline-injected damselflies for one day and 15°C to subsequently house damselflies following immune challenges versus control injections.

#### Study Species

*Enallagma boreale* is a non-territorial damselfly with a mating system that can be

defined as scramble mate competition [52]. *E. boreale* is found throughout eastern Ontario at beaver ponds and freshwater marshes [53]. Emergence of *E. boreale* usually begins at the end of May and mature adults are present through to mid to late June [53]. As with many dragonfly and damselfly species, *E. boreale* are subject to parasitism by larval water mites (Acari: Hydrachnida). During host emergence, the water mites transfer to newly eclosed adult damselflies and become parasitic [54]. The mites engorge during the host maturation period and return to the water during host reproduction. Host resistance to parasitism (melanotic encapsulation of the mite feeding resulting in death of the mite) will occur during the first 24–48 h after emergence [4].

#### Collections

Male and female *E. boreale* were collected from Jack's Marsh near the Queen's Biology Station near Chaffeys lock Ontario, Canada (44° 34' N, 79° 15' W). Newly emerged damselflies were collected on a daily basis beginning 28 May through to the 1 June 2005 between 1000 and 1200 h. For collections of mature adult damselflies, we collected the first individuals to be observed in tandem, ensuring males and females were reproductively mature and within a similar age group [31]. We collected reproductively mature damselflies on 6–8 and 10–11 June 2005 (no adults were observed in tandem on the 9 June between 1000 h and 1200 h). We attempted to collect equal numbers of damselflies each day. In total, 118 newly-emerged and 180 reproductively mature *E. boreale* were collected. Each day damselflies were brought back to the Queen's Biology Station (within 15 min of the collection site) in insect cages (30 cm . 30 cm . 40 cm) and placed in a cool (ca. 18°C) dark room for one hour. Individuals were weighed ( $\pm 0.001$  g; Mettler AE100 Digital Scale) and placed in plastic cups (volume ca. 255 ml) covered with aluminium foil. Each plastic cup contained 2 ml of water under a metal mesh screen to prevent drowning of the damselfly

and a wooden stick was placed in the cup to provide a perch. At this time, we enumerated parasitic water mites on each individual using a 20. loupe. We assigned both newly emerged and mature damselflies used to assay immune parameters to treatment groups (LPS or saline injected) within a sex ensuring there were no differences in our measures of body size, wing length and body mass ( $p$  values range from 0.22 to 0.98). Before assessing survival, we also assigned males and females to treatments ensuring there was no difference in average mass or wing length between treatment groups within a sex (Table 2).

Parasitic water mites (*Arrenurus* spp.) observed on some damselflies could not be

removed prior to experimentation without causing greater stress. Therefore, we ensured that the number of mites on newly emerged *E. boreale* did not differ between treatment groups for each sex prior to assays of immune parameters (zeros were included in analyses; males,  $W = 16$ ,  $p = 0.99$ ,  $n = 10$ ; females,  $W = 28.5$ ,  $p = 0.23$ ,  $n = 16$ ) and the survivorship experiment (Table 2). We also ensured that the number of mature *E. boreale* with mites was similar between treatment groups for each sex prior to assaying immune parameters and prior to conducting the survivorship experiment. However, we did not statistically compare mean mite intensity between treatments as the infection levels were low (see legend of Table 2).

**Table 2.** Means  $\pm$  1 SE of mass, wing length and median number of mites on newly emerged and mature *Enallagma boreale* for saline injected and LPS injected groups used in the survivorship experiment.

		Mass (g) <sup>1</sup>		Wing Length (mm) <sup>1</sup>		Mites <sup>2</sup>	
		Saline	LPS	Saline	LPS	Saline	LPS
Newly Emerged	Males	0.328 $\pm$ 0.007	0.324 $\pm$ 0.007	12.87 $\pm$ 0.15	12.91 $\pm$ 0.11	7 (3 – 10)	4 (3 – 11)
	Females	0.350 $\pm$ 0.008	0.345 $\pm$ 0.008	13.81 $\pm$ 0.15	13.64 $\pm$ 0.16	4 (2 – 10)	5 (1 – 12)
Mature	Males	0.304 $\pm$ 0.007	0.313 $\pm$ 0.007	13.07 $\pm$ 0.11	13.14 $\pm$ 0.09	0 (0-0)	0 (0-0)
	Females	0.464 $\pm$ 0.014	0.469 $\pm$ 0.010	13.79 $\pm$ 0.12	13.74 $\pm$ 0.13	0 (0-0)	0 (0-0)

<sup>1</sup>No differences in mass or wing length were found between treatment groups within each age and sex category (Newly Emerged: Mass-males,  $t_{40} = -1.52$ ,  $p = 0.14$ ; females,  $t_{48} = -1.53$ ,  $p = 0.13$ ; Wing length-males,  $t_{40} = 0.27$ ,  $p = 0.79$ ; females,  $t_{48} = 0.83$ ,  $p = 0.41$ ; Mature: Mass-males,  $t_{57} = -0.91$ ,  $p = 0.36$ ; females,  $t_{59} = -0.44$ ,  $p = 0.66$ ; Wing length-males,  $t_{57} = -0.50$ ,  $p = 0.62$ ; females,  $t_{59} = 0.31$ ,  $p = 0.76$ ).<sup>2</sup>No differences between the median number of parasitic water mites (interquartile ranges are indicated in brackets) were found for saline injected and LPS injected newly emerged *E. boreale* (zeros were included in analyses; males,  $W = 161$ ,  $p = 0.16$ ; females,  $W = 275.5$ ,  $p = 0.63$ ). Few (8) mature adults were found with mites and therefore no statistical tests were completed, although medians and interquartile ranges are reported. Two males that were saline-injected carried 2 and 27 mites, three males that were LPS-injected carried 4, 5 and 15 mites. One female that was saline-injected carried three mites and two LPS-injected females carried one and two mites.

Of the 60 mature damselflies used to assess immune parameters 5 had mites-1 female with 14 mites and 1 male with 1 mite in the LPS treatment while 1 female with 18 mites and 2 males with 1 mite each were assigned to the saline treatment. Eight mature damselflies used in the survivorship experiment had mites out of the 120 in total or approximately 7% (Table 2). These individuals were not expected to sway analyses because they were few in number

and their mite numbers were similar across treatments. Nonetheless, analyses were completed without these individuals, but did not change the overall outcome (see Results).

#### Immune Parameters

To assess if activation of one or more immune parameters occurs at 22°C, 16 newly emerged females and 10 newly emerged males and 30 mature females and 30 mature males were examined. Damselflies used to assess immune induction were not used in

survivorship experiments. To assess if an immune parameter was induced, we compared Lippolysaccharide (LPS)-injected individuals to saline-injected controls. Three assays were completed to assess immune activation for each individual and all were completed at the same time as the survivorship experiments.

Each individual assigned to LPS-injected group was injected through the ventral surface of the metaepimeron with 0.5  $\mu$ l of 0.5 mg/ml LPS (Sigma) dissolved in ice-cold insect Ringers saline solution using a 32 gauge Hamilton Syringe (Hamilton Company). Individuals assigned to the saline treatment were similarly injected but with 0.5  $\mu$ l of the insect Ringers saline solution alone. Immune activation was achieved through the injection of LPS and individuals were housed at 22°C for 12 h. We chose 22°C to ensure an immune response occurred within the 24 h. This temperature also was chosen for reasons detailed above and because it was an ideal temperature at which adult damselflies could be housed (T. Robb, personal observation). After 12 h at 22°C, we immediately collected haemolymph from the thorax of each injected damselfly by pushing 40  $\mu$ l of ice cold sodium cacodylate buffer (0.01 M sodium cacodylate, 0.005 M calcium chloride, pH 7.4) through the thorax using a 26 gauge Hamilton Syringe. The haemolymph and buffer were collected in a 1.0 ml eppendorf held on ice. From this mixture of haemolymph and buffer we removed 10  $\mu$ l for a haemocyte count and the remainder was frozen at -30°C to disrupt haemocytes for measure of PO activity and antibacterial activity. The number of haemocytes was determined using an improved Neubauer hemocytometer.

Phenoloxidase activity was determined by quantifying the conversion of L-3,4-dihydroxyphenylalanine (L-DOPA) to melanin catalyzed by PO [55]. Filter paper (Whatman No.52) cut in halves was soaked in 2 mg/ml L-DOPA (Sigma) in a sodium cacodylate buffer and 6  $\mu$ l of the damselfly

haemolymph solution was applied to the centre of the filter paper. Samples were kept for 30 min at room temperature and filter paper was kept moist with additional L-DOPA solution to allow excess substrate for the reaction to occur. Samples were then transferred to clean paper towel and allowed to dry. The end result was a circular melanised spot on the filter paper as a result of the PO present in the haemolymph solution. The PO activity was quantified by calculating a mean of the greyscale values for the melanised region. The addition of buffer alone resulted in no colour (melanisation) indicating melanin was produced as a result of the PO in the haemolymph. Multiple pieces of filter paper were scanned using a Cannon Scanner (CannoScan 9900F) set at 200 dpi, greyscale, 8 bits per colour, no automatic tone curve and high sharp-ness (60%). For each sample a mean greyscale pixel value of a circular region (364 pixels) at the visually estimated centre of the melanised spot was determined using UTH SCSA ImageTool program Version 3.0 [56]. A raw mean pixel value (RMPV) was calculated by subtracting the mean greyscale pixel value from 255; thus a value of 255 represented black and 0 represented white. To convert the RMPV values to a standardised measure of PO activity or the melanisation index (MI) a standard India ink solution (Faber-Castell Waterproof drawing ink no 4415) was used. The mean RMPVs for three aliquots at twelve dilution levels of the India ink solution was determined using the above methods (dilution levels range from undiluted to a dilution factor of 2<sup>-12</sup>, in decrements of powers of 2) and the best fit function of the curve (dilution versus RMPV) was calculated. The MI for each damselfly sample was computed as  $MI = e [(RMPV - b)/m] * 100\%$  (where m was the slope of the best fit function and b was the intercept). For each individual the MI for three separate samples was determined and the mean MI was used for comparison of LPS injected versus saline injected controls.

Antibacterial peptides also are produced in response to infection and can be measured by testing haemolymph effectiveness at killing live bacteria (e.g. [14]). Antibacterial activity of the damselfly haemolymph was determined using a zone of inhibition assay against the bacteria *Arthrobacter globiformis*. Methods were completed similar to Moret & Schmid-Hempel [14]. Test plates (5 for newly emerged and 12 for mature adults) were made by adding

0.05 ml of *A. globiformis* ( $10^5$  cells/ml) to 5 ml of nutrient agar and the plates were swirled to distribute bacteria evenly. Plates were left to settle at room temperature and then stored upside down at 4°C for up to two days prior to use. Six pieces of sterilised circular filter paper (6.29 mm in diameter) were placed on each test plate and 6 µl of the damselfly haemolymph mixture was pipetted on a single filter paper. Placement of samples on each plate and between plates was random to ensure each plate had samples from both treatments for each sex. On each plate, a negative control consisting of 6 µl of buffer alone was pipetted on a single filter paper. Plates were incubated upside down at 28°C for 24 h. The diameter of the clear zone around the filter paper was measured using digital callipers. The average of the minimum and maximum diameters was used for comparison. Bacteria growth was not inhibited by the buffer alone.

#### Survivorship

Upon collection of newly emerged adult damselflies (50 females and 42 males), individuals were assigned to one of two treatment groups: saline-injected or LPS-injected. Injections and doses of LPS and saline were completed as above. After the injection, individuals were placed back in the plastic cups and held at 22°C (16:9 light:dark cycle, similar to that under natural conditions) for a 24-h time period to allow for the induction of the immune response.

Individuals were then placed into a 15°C incubator with the same light:dark

cycle. This starvation and temperature regime should mimic 'real' occurrences of adverse weather and limited food availability. Damselflies were observed approximately every 12 h at which time if individuals were dead the date was recorded as well as wing length ( $\pm 0.01$  mm; Mitutoyo digital callipers). Observations were completed until all individuals were dead. To determine survivorship differences of LPS-injected and saline injected mature adults, the same methods as outlined above were completed using reproductively mature *E. boreale* (61 females and 59 males). Differences in sample sizes between newly emerged and mature damselflies and between sexes occurred as a result of differences in number of individuals available at the field site during the collection periods.

#### Statistical Analyses

All analyses were completed using R (version 2.1.1; [57]) and means are reported as  $\pm 1$  SE. Body mass, wing length, haemocyte concentration and MI were log transformed to meet the assumptions of normality. Analysis of antibacterial response was completed with plate as a random block effect to account for variation in bacteria between the plates. Two LPS injected mature damselflies (one male and one female) were removed from the MI analysis and one LPS injected newly emerged female damselfly was removed from the antibacterial analysis due to an error in the laboratory.

Separate analyses were completed for newly emerged and reproductively mature individuals and any non-significant interactions were removed for final analyses. We completed separate analyses because newly emerged and mature individuals were collected at different times of the season thus we could only explain the variation in survivorship and immune parameters within each age category and discuss if there were differences in explanatory variables.

#### Authors' contributions

TR carried out the field collections and laboratory procedures and drafted the



manuscript. MRF participated in the study design and coordination and helped to draft the manuscript. Both authors read and approved the final manuscript.

#### Acknowledgements

We thank Jamie MacDougall for field assistance. Dr. Bill Willmore and Dr. Thor Arnason assisted in the methods of the immune assays. We also thank three anonymous reviewers for helpful suggestions on statistical analyses and comments on the manuscript. Funding was provided by the Natural Sciences and Engineering Research Council of Canada to MRF.

#### References:

- Ferrari J, Muller CB, Kraaijeveld AR, Godfray HCJ: Clonal variation and covariation in aphid resistance to parasitoids and a pathogen. *Evolution* 2001, 55:1805-1814.
- Jackson JA, Tinsley RC: Parasite infectivity to hybridising host species: a link between hybrid resistance and allopolyploid speciation? *International Journal for Parasitology* 2003, 33:137-144.
- Zuk M, Stoehr AM: Immune defense and host life history. *American Naturalist* 2002, 160:S9-S22.
- Yourth CP, Forbes MR, Smith BP: Immune expression in a damselfly is related to time of season, not to fluctuating asymmetry or host size. *Ecological Entomology* 2002, 27:123-128.
- Robb T, Forbes MR: On understanding seasonal increases in damselfly defence and resistance against ectoparasitic mites. *Ecological Entomology* 2005, 30:334-341.
- Fellowes MDE, Godfray HCJ: The evolutionary ecology of resistance to parasitoids by *Drosophila*. *Heredity* 2000, 84:1-8.
- Norris K, Evans MR: Ecological immunology: life history trade-offs and immune defense in birds. *Behavioral Ecology* 2000, 11:19-26.
- Cotter SC, Wilson K: Heritability of immune function in the caterpillar *Spodoptera littoralis*. *Heredity* 2002, 88:229-234.
- Kraaijeveld AR, Godfray HCJ: Trade-off between parasitoid resistance and larval competitive ability in *Drosophila melanogaster*. *Nature* 1997, 389:278-280.
- Sheldon BC, Verhulst S: Ecological immunology: Costly parasite defences and trade-offs in evolutionary ecology. *Trends in Ecology & Evolution* 1996, 11:317-321.
- Lochmiller RL, Deerenberg C: Trade-offs in evolutionary immunology: just what is the cost of immunity? *Oikos* 2000, 88:87-98.
- Rigby MC, Hechinger RF, Stevens L: Why should parasite resistance be costly? *Trends in Parasitology* 2002, 18:116-120.
- Sandland GJ, Minchella DJ: Costs of immune defense: an enigma wrapped in an environmental cloak? *Trends in Parasitology* 2003, 19:571-574.
- Moret Y, Schmid-Hempel P: Survival for immunity: The price of immune system activation for bumblebee workers. *Science* 2000, 290:1166-1168.
- Mckean KA, Nunney L: Bateman's principle and immunity: Phenotypically plastic reproductive strategies predict changes in immunological sex differences. *Evolution* 2005, 59:1510-1517.
- Doums C, Schmid-Hempel P: Immunocompetence in workers of a social insect, *Bombus terrestris* L., in relation to foraging activity and parasitic infection. *Canadian Journal of Zoology* 2000, 78:1060-1066.
- Koella JC, Sorensen FL: Effect of adult nutrition on the melanization immune response of the malaria vector *Anopheles stephensi*. *Medical and Veterinary Entomology* 2002, 16:316-320.
- Nigam Y, Maudlin I, Welburn S, Ratcliffe NA: Detection of phenoloxidase activity in the hemolymph of tsetse flies, refractory and susceptible to infection with *Trypanosoma brucei rhodesiense*. *Journal of Invertebrate Pathology* 1997, 69:279-281.
- Gray DA: Sex differences in susceptibility of house crickets, *Acheta domesticus*, to experimental infection with *Serratia liquefaciens*. *Journal of Invertebrate Pathology* 1998, 71:288-289.
- da Silva C, Dunphy GB, Rau ME: Interaction of hemocytes and phenoloxidase system of fifth instar nymphs of *Acheta domesticus* with bacteria. *Developmental and Comparative Immunology* 2000, 24:367-379.
- Kurtz J, Wiesner A, Gotz P, Sauer KP: Gender differences and individual variation in the immune system of the scorpionfly *Panorpa vulgaris* (Insecta : Mecoptera). *Developmental and Comparative Immunology* 2000, 24:1-12.
- Kurtz J, Sauer KP: Gender differences in phenoloxidase activity of *Panorpa vulgaris* hemocytes. *Journal of Invertebrate Pathology* 2001, 78:53-55.
- Gillespie JP, Kanost MR, Tenczek T: Biological mediators of insect immunity. *Annual Review of Entomology* 1997, 42:611-643.
- Strand MR, Pech LL: Immunological Basis for Compatibility in Parasitoid Host Relationships. *Annual Review of Entomology* 1995, 40:31-56.
- Schmid-Hempel P: Evolutionary ecology of insect immune defenses. *Annual Review of Entomology* 2005, 50:529-551.

26. Forbes MRL, Baker RL: Condition and Fecundity of the Dam-selfly, *Enallagma-Ebrium* (Hagen) - the Importance of Ectoparasites. *Oecologia* 1991, 86:335-341.
27. Folstad I, Karter AJ: Parasites, Bright Males, and the Immuno-competence Handicap. *American Naturalist* 1992, 139:603-622.
28. Zuk M, Mckean KA: Sex differences in parasite infections: Pat terns and processes. *International Journal for Parasitology* 1996, 26:1009-1023.
29. Schmid-Hempel P: Variation in immune defence as a question of evolutionary ecology. *Proceedings of the Royal Society of London Series B-Biological Sciences* 2003, 270:357-366.
30. Anholt BR, Marden JH, Jenkins DM: Patterns of Mass Gain and Sexual Dimorphism in Adult Dragonflies (Insecta, Odonata). *Canadian Journal of Zoology* 1991, 69:1156-1163.
31. Corbet PS: *Dragonflies: Behavior and Ecology of Odonata* Ithaca, New York, Cornell University Press; 1999.
32. Marmaras VJ, Charalambidis ND, Zervas CG: Immune response in insects: The role of phenoloxidase in defense reactions in relation to melanization and sclerotization. *Archives of Insect Biochemistry and Physiology* 1996, 31:119-133.
33. Rolff J: Effects of age and gender on immune function of drag-onflies (Odonata, Lestidae) from a wild population. *Canadian Journal of Zoology* 2001, 79:2176-2180.
34. Schwarzenbach GA, Hosken DJ, Ward PI: Sex and immunity in the yellow dung fly *Scathophaga stercoraria*. *Journal of Evolutionary Biology* 2005, 18:455-463.
35. Jacot A, Scheuber H, Brinkhof MWG: Costs of an induced immune response on sexual display and longevity in field crickets. *Evolution* 2004, 58:2280-2286.
36. Fellowes MDE, Kraaijeveld AR, Godfray HCJ: Trade-off associated with selection for increased ability to resist parasitoid attack in *Drosophila melanogaster*. *Proceedings of the Royal Society of London Series B-Biological Sciences* 1998, 265:1553-1558.
37. Armitage SAO, Thompson JJW, Rolff J, Siva-Jothy MT: Examining costs of induced and constitutive immune investment in *Tenebrio molitor*. *Journal of Evolutionary Biology* 2003, 16:1038-1044.
38. Yourth CP, Forbes MR, Smith BP: On understanding variation in immune expression of the damselflies *Lestes* spp. *Canadian Journal of Zoology-Revue Canadienne de Zoologie* 2001, 79:815-821.
39. Hecker KR, Forbes MR, Leonard NJ: Parasitism of damselflies (*Enallagma boreale*) by gregarines: sex biases and relations to adult survivorship. *Canadian Journal of Zoology-Revue Canadienne de Zoologie* 2002, 80:162-168.
40. Coustau C, Chevillon C, ffrench-Constant R: Resistance to xeno-biotics and parasites: can we count the cost? *Trends in Ecology & Evolution* 2000, 15:378-383.
41. Reeson AF, Wilson K, Gunn A, Hails RS, Goulson D: Baculovirus resistance in the noctuid *Spodoptera exempta* is phenotypi-cally plastic and responds to population density. *Proceedings of the Royal Society of London Series B-Biological Sciences* 1998, 265:1787-1791.
42. Wilson K, Cotter SC, Reeson AF, Pell JK: Melanism and disease resistance in insects. *Ecology Letters* 2001, 4:637-649.
43. Ohgushi T: A reproductive tradeoff in an herbivorous lady beetle: Egg resorption and female survival. *Oecologia* 1996, 106:345-351.
44. Fincke OM: Lifetime Mating Success in A Natural-Population of the Damselfly, *Enallagma-Hageni* (Walsh) (Odonata, Coe-nagrionidae). *Behavioral Ecology and Sociobiology* 1982, 10:293-302.
45. Bai GX, Johnston LA, Watson CO, Yoshino TP: Phenoloxidase activity in the reproductive system of *Biomphalaria glabrata*: Role in egg production and effect of schistosome infection. *Journal of Parasitology* 1997, 83:852-858.
46. Li JY, Tracy JW, Christensen BM: Phenol Oxidase activity in hemolymph compartments of *Aedes aegypti* during melan-otic encapsulation reactions against microfilariae. *Developmental and Comparative Immunology* 1992, 16:41-48.
47. Joop G, Mitschke A, Rolff J, Siva-Jothy M: Immune function and parasite resistance in male and polymorphic female *Coena grion puella*. *Bmc Evolutionary Biology* 2006, 6:19.
48. Rolff J: Bateman's principle and immunity. *Proceedings of the Royal Society of London Series B-Biological Sciences* 2002, 269:867-872.
49. Zuk M: Reproductive Strategies and Disease Susceptibility An Evolutionary Viewpoint. *Parasitology Today* 1990, 6:231-233.
50. Moore SL, Wilson K: Parasites as a viability cost of sexual selec tion in natural populations of mammals. *Science* 2002, 297:2015-2018.
51. Forbes M: Tests of Hypotheses for Female-Limited Polymor-phism in the Damselfly, *Enallagma-Boreale* Selys. *Animal Behaviour* 1994, 47:724-726.
52. Fincke OM: Female Color Polymorphism in Damselflies -Fail-ure to Reject the Null Hypothesis. *Animal Behaviour* 1994, 47:1249-1266.
53. Forbes MR: Female morphs of the damselfly *Enallagma bore-ale* Selys (Odonata: Coengrionidae): a benefit for androchro-

- matypes. *Canadian Journal of Zoology* 1991, 61:1969-1970.
54. Smith BP: Host-parasite interactions: impact of larval water mites on insects. *Annual Review of Entomology* 1988, 33:487-587.
55. Sorrentino RP, Small CN, Govind S: Quantitative analysis of phenol oxidase activity in insect hemolymph. *Biotechniques* 2002, 32:815-823.
56. University of Texas Health Science Center: UTHSCSA ImageTool program Version 3.0. 2006[ <http://ddsdx.uthscsa.edu/dig/itdesc.html> ].
57. Ihaka R, Gentleman R: R: a language for data analysis and graphics. *Journal of Computational and Graphical Statistics* 1996, 5:299-314.

## SEASONAL BIORHYTHMS AS A FEATURE OF HUMAN GENETIC SYSTEMS

Talalaeva G.V., Khokhutkin I.M.

Institute of Plants and Animals Ecology UrD RAS

---

Genetic systems are of great prevalence in nature. They are characterized by interrelation between three sequential functional statuses of complex biological systems: Past, Present and Future; and differ from occasional processes by an After-effect. Traditionally the models of genetic systems are used in Biology for description of Genetic Heredity and Genetic Variability. At the present work the models of genetic systems are used to describe human phenotypic variability. We also present a comparative analysis of seasonal biorhythms in two groups under study: Ural and Northern, residents of Midlatitudes and immigrants from Midlatitudes, Polar region migrants correspondingly. Discrete statuses of biorhythms pattern, interrelated within the flow of nonrandom sequential events are described. We show, that the biorhythms modification, formed in past, is a stable phenomenon, it can not be cleared by corrective impact in present and determines the stimulation response of human organism in future. The interpretation of the results is made in the models of genetic processes: the complex of seasonal biorhythms is defined as a self-optimizing system having an after-effect; and its discrete statuses are described as a dynamic sequence of events in that system.

---

### **Problem description**

Genetic systems are of great prevalence in nature. They make possible appropriate descriptions of complex biological systems having an after-effect. Genetic Systems Theory as currently applied to Biology is Genetic Heredity and Genetic Variability. The researches of the Urals scientists in genetic systems theory use for phenotypic variability modeling are not so familiar [1 - 4].

Our concern in presentation of phenotypic variability in the scheme of genetic systems can be explained as follows. Modern living environment suffers anthropogenic and industrial transformation. The tempo of artificial transformation of environment is many times as quicker than human evolution as a species, if we can take into consideration only the processes of genetic variability, caused by mutation. Steady increase of disproportion between the tempo of environment transformation and genotype evolution menaces human survival as a species. This is a new scientific problem. We believe that its successive solution is possible if the mechanisms of human adaptation fitting with rapidity, self-

organization and ability to function within the schemes of genetic systems are discovered.

The aim of the present research is to analyze the human seasonal biorhythms within the theory about self-organizing systems having an after-effect.

### **Stuff and Methods of investigation**

The seasonal biorhythms are investigated in two categories of individuals having the initial signs of disadaptation syndrome and various geographic pre-history. The results of examination of men, suffering the ischemic heart disease (IHD) working at metallurgical plants of the Middle Urals (first group, 113 persons) and Polar region (second group, 102 persons) are taken in operation. The groups match in age, prescription of the disease and the main signs of the disease. The clinical characteristics of patients with IHD from various geographic groups was similar in follow aspects: age, prescription of the disease, complaints (heart pain, typical irradiation of pain, neurosis-like complaints), data of medical examination (heart edge extension to the left, apical systolic murmur, accent in II tone in aorta), electrocardiography and X-ray data, liquid

homeostasis factors (advanced hydrocortone antibody titer, cholesterolin and triglyceride level)

Along with it, seasonal biorhythms in two groups under study differ substantially, being not just a complex of discrete rhythmical processes, but functional systems able to self-organization and self-

development. Seasonal biorhythms of the inhabitants of the Middle Urals industrial region are nearer to the rhythm of climate and weather fluctuations in the Midlatitudes and demonstrate authentic seasonal periodicity in the most of homeostasis factors analyzed (tab. 1)

**Table 1.** - Seasonal biorhythms of tolerance to exercise stress of IHD patients from various geographic groups (residents of the Urals and the Polar region)

Factors	Winter	Spring	Summer	Autumn
The Urals residents				
CR at rest (beats/minute)	72.19±2.93 *	63.62±2.43	71.70±3.69	71.36±2.23
Interval PQ, sec*10 <sup>-2</sup>	15.89±0.34 *	16.29±0.33	14.80±0.62	16.45±0.44
Systolic factor, %	2.18±0.34 *	1.29±0.29	1.50±0.68	1.74±0.35
Vegetal Index Kerde	-10.84±3.57 *	-23.51±4.30	-9.75 ±3.54	-15.32±4.55
Volume of the work done, kilogrammeter	5456.25 ±834.59 *	7128.57 ±639.04	9344.12 ±877.46	4764.00 ±521.80
Cholesterin mmol/l	6.41±0.20 *	6.46±0.17	7.14±0.41	6.45±0.19
Betalipoproteins, g/l	6.92±0.54 *	6.30±0.28	7.39±0.76	6.30±0.28
the Atherogenic index	3.18±0.23 *	2.63±0.18	3.80±0.57	2.78±0.22
triglyceride mmol/l	1.06±0.10 *	1.26±0.07	1.39±0.19	1.29±0.11
The Polar region nonresidents				
CR at rest (beats/minute)	75.31±2.07	71.09±1.82	72.09±2.10	72.82±4.04
Interval PQ, sec*10 <sup>-2</sup>	16.15±0.40 *	16.07±0.23	15.03±0.20	15.96±0.36
Systolic factor, %	2.31±0.25	2.48±0.42	2.31±0.20	2.72±0.42
Vegetal Index Kerde	-11.31±5.12	-16.73±7.28	-14.12±4.66	-15.30±8.43
Volume of the work done, kilogrammeter	7868,75 ±554,04	8382,00 ±654,19	7421,74 ±422,66	6703,85 ±660,15
Cholesterin mmol/l	6.87±0.25	6.78±0.22	6.86±0.26	6.96±0.29
Betalipoproteins, g/l	6.81±0.55	7.48±0.44	6.98±0.44	7.48±0.50
the Atherogenic index	3.04±0.19	3.08±0.14	2.78±0.30	3.27±0.30
triglyceride mmol/l	1.08±0.09	1.17±0.11	1.04±0.09	1.10±0.10

NOTE (\*) – the dynamics inside a group during the seasons is authentic, p<0.05

Statistically important seasonal biorhythm is registered in PQ interval value that is the speed of electric arousal distribution in atrium and in systolic ECG factor that is the effectiveness of electric activity in myocardium. The range of seasonal fluctuations of these factors has been substantial for a year: it has made 10.3% for the length of PQ interval, and 53.3% for systolic factor average annual. The dynamic of cardiac rate (CR) hasn't got the

degree of statistic authenticity, but nevertheless, it follows the seasonal pattern of systolic factor, i.e. is synchronized with it in the phase of rhythm. CR is higher in winter and in summer and it is lower in spring and in autumn. Qualitative seasonal evaluation shows the absence of authentic seasonal distinctions in frequency and character of pathologic variations in ECG in the group of the Urals residents under study. It may be interpreted as a rather high

efficiency of annual heart electric activity of IHD patients from the Urals region. The residents of The Urals have inter-synchronized variations of pulse, double product and vegetation index Kerde at rest. The seasonal variations have 2 cycles in a year (the rates increase in summer and in winter and decrease in spring and in autumn) and inversion in relation to seasonal fluctuations of diastolic blood pressure.

Variations of systolic arterial tension (AT) and tolerance to exercise stress (TES) has one peak each during the year, dislocated relative to each other in a season: the highest level of systolic blood pressure is registered in spring, and physical efficiency is the highest in summer. Fluctuations of CR, of involuntary nervous system tonus (index Kerde) and TES are statistically important; the range of there fluctuations is 12.3%, 87.9% and 70.3% of annual average. Variations of AT and double product (DP) that characterizes oxygen consumption by myocardium, at rest are unessential during the year, and their ranges are lower than those of the forgoing factors. The range of seasonal variations of systolic AT makes 3.4% of the annual average, 3.2% for diastolic AT and 10.4% for DP.

The range of seasonal variations of cholesterol level in blood makes 11.1% of annual average, 16.4% for betalipoprotein, 26.6% for triglyceride, and 39.0% for the Atherogenic index. Seasonal variations of blood cholesterol, betalipoprotein and the Atherogenic index are synchronized and show the increase of hyperlipemia patients quantity twice a year – in winter and in summer and sequent decrease in spring and autumn. The dynamic of blood triglyceride is inverse.

The seasonal variations of physiological factors in the group of the Urals residents show that 17 of 28 homeostasis number factors have authentic seasonal biorhythms; 13 of them have evident 6-month component and biorhythms look like a two-peak curve.

The specific character of seasonal biorhythms of the Polar region nonresidents-IHD patients is as follows. The Northerners are different in the range (2.0 – 4.8 times lower) of seasonal variations of circulatory dynamics, liquid homeostasis and immunological status up to absence of any statistical differences in a number of factors analyzed during the year. Seasonal variability of bioelectric heart activity in the group of the Northerners also differ from the same of the Midlatitudes residents. The difference is that the ranges of interseasonal fluctuations in the group of the Northerners are even, authentic biorhythm is found only in one of the analyzed ECG factors (PQ rhythm).

Seasonal rhythm of the Northerners in comparison with the Urals residents is characterized by the slower variations of the factors analyzed during the year. Two-peak curve of annual biorhythms, common to ECG parameters of the Urals residents, continues only in systolic factors of the Northerners. Other ECG factors in the group of the Northerners have only one peak a year that is the fact of biological time slowdown in this group in comparison with the Urals group. Besides maximum value of slow waves fluctuations in the group of the Northerners have phase deviation in time and are in disagreement: the maximum value of PQ interval length biorhythm is in winter, CR – in spring, QRS interval length (ventricular excitability) – in autumn. It is not impossible that the type of seasonal rhythms of the Northerners is approximate to the peculiarity of photoperiodism in the polar region with long polar day and wasting polar night, fully level by their length the processes of rapid spring and autumn. Seasonal variations of CR, systolic AT, DP and Kerde index show the tendencies to have two cycles of fluctuations during a year with the increase in winter and in summer and decrease in spring and autumn. However maximum value of the indicated factors is in summer and minimum value – in spring. The dynamics of diastolic AT is more monotonous, gradually

decreasing from maximum value in autumn to minimal value in spring. The range of CR seasonal fluctuations makes 5.8% of the annual average, 8.3% and 3.5% for systolic and diastolic AT correspondingly, and 38.5% for Kerde index. CR, AT, DP and Kerde index fluctuations in seasons are insignificant and do not make authentic differences as when intercomparing the seasons, so comparing the seasons and the annual average.

Seasonal variations of cholesterol, betalipoprotein, triglyceride in blood and the Atherogenic index of polar region IHD patients are not statistically significant as in absolute values of the foregoing factors, so in the number of hyperlipemia patients, testifying to stable hyperlipemia during the whole year and to the absence of authentic seasonal biorhythms of liquid homeostasis factors. The range of cholesterol seasonal fluctuations makes 2.6% of the annual average, 9.3% for betalipoprotein, 11.7% for triglyceride and 15.6% for the Atherogenic index in the Polar region.

Only 7 of 28 homeostasis numeric parameters analyzed in the Polar region group have authentic seasonal variations. So the Northerners, in comparison with the Urals residents, have a spectrum of seasonal biorhythms providing the climate and geographic adaptability more rigid and narrower in range, consisting of smaller number of authentic rhythmical fluctuations. Comparison of the schemes of the Northerners' and the Urals residents' seasonal neorhythmostasis made on the measuring at rest, shows a constriction of the physical fluctuations corridor of the people at stress, experienced the severe Polar climate and geographic environment.

Nevertheless within the present message another aspect of experimental data under study is more important. It is important, that the people having equal severity of the general adaptability syndrome

defect (primary evidences of IHD) have different schemes of their seasonal biorhythms and therefore may have different response to additional effect of industrial factors of the environment. The results of physical therapy realized in hospital environment were measured to verify the stated supposition.

Successful adaptation of IHD patients from the Midlatitudes to the changing environment may be proved not only by their safe seasonal biorhythms, but also by the fact that their clinical state didn't suffer any substantial breakdown during the year. The complex physical therapy was more effective in intermediate seasons: in spring and in autumn, and especially in autumn (table 2). The nonresidents of the Polar region have a different scheme of the biorhythms system and algorithm of its response to the outer influence that that of the Middle Urals residents.

The Northerners have no statistically significant fluctuations of homeostasis factors during the year. Substantial breakdown of clinical evidences of the disease in winter and autumn period was registered. Physical therapy was the least effective in intermediate seasons: in spring and in autumn, and especially in autumn.

Comparison of the results of examination in the two groups (table 3) shows that the effectiveness of treatment of the Urals residents has authentic seasonal variability; seasonal fluctuations in effectiveness of treatment in the group of Northerners are not statistically significant. There is a definite seasonal dynamics of TES factors, oxygen pulse and the factor of energy consumption for a stress unit in the structure of biological time of the Urals residents after a course of impulse physical therapy. In the group of Northerners there is no seasonal rhythmic of the physiological factors analyzed after a course of physical therapy.

**Table 2.** Clinical effectiveness of physical therapy of IHD patients from various geographic groups according to the season of treatment (% of the whole number of cured in a season)

Factors	Considerable improvement	Improvement	Insignificant improvement	No changes	Breakdown
The Urals residents					
Winter, n=27	-	92.8	3.6	3.6	-
Spring, n=34	8.8	76.5	11.8	2.9	-
Summer, n=20	-	85.0	10.0	5.0	-
Autumn, n=31	16.1*	67.7	9.7	6.5	-
The Polar region nonresidents					
Winter, n=26	-	84.6	7.7	3.8	-
Spring, n=29	3.3	83.3	6.6	3.3	3.3
Summer, n=22	8.6	87.0	-	4.3	-
Autumn, n=25	8.6	78.3	4.3	8.6	-

NOTE (\*) – In pair comparison (spring-autumn) – (winter-summer) the differences in the effectiveness of treatment in the Urals group were authentic ( $P < 0.01$ ). In the Northern group authentic differences were not found out.

### Discussion

The results, to our opinion, may be interpreted as follows. There are 3 sequential phases in the both groups under study: 1 – the initial status before the treatment, 2- the period of treatment itself and 3- the final response to the completed treatment. When modeling the process in the perms of genetic systems the situation may be presented as follows. The initial phenotype of seasonal biorhythms of the people under study specified by geographic peculiarities of their permanent residence is the prior status, or prehistory. The state of biorhythms at the moment of admission to the clinic and during the treatment is the current event, causing the response of the multicomponent homeostasis system in the organisms of the patients cured. Clinical effectiveness of the treatment conducted and transformation of the biorhythmologic status of the cured after the course of treatment is the after-effect, caused by the interaction in the initial status of the system and its responsiveness at the present moment. That is to say, clinical effect of the treatment may be considered as an after-effect of the events that happened at previous

stages of ontogenesis during the process of life activity of an organism.

In our research the initial functional status in two groups under study was the same concerning all parameters, excepting the state of their biorhythms. According with it, one can logically suppose that the status of biorhythms itself is the carrier of the key information determining unequal response of the patients organisms from the first and the second group to the same course of treatment. As far as the final (after the treatment) state of biorhythms of the patients from the groups under study remained not unified with qualitative differences, we may state that further provocative environmental impact will be accepted differently by the patients from the first and the second group and have different results.

Thus, various climate and geographic prehistory of the patients destined different action of their system of biorhythms in present and extended to the result of the treatment that logically extrapolates in future. Various biorhythmic status of the patients in past caused various reactivity in present and resulted in various effects of treatment thereafter. The course of treatment in autumn



was the most effective for the patients from the Midlatitudes and on the contrary the least successful for the Northerners.

As one can see from the displayed data there are diverse processes of homeostatic regulations in subpopulations of *Homo sapiens*. By means of different modes of changeability in these subdivisions two various in quality subtypes of “industrial” communities of people form. According the factor of organization of seasonal biorhythms the groups under investigation formed two sets various in quality, two various types of self-organizing systems differentiating in algorithm of perception, processing and reproduction of information from their prior state through the present into the future.

#### **Conclusion**

Human biorhythms are not only the carriers of the information about the algorithm of an organism functioning in the past, present and future; they are also the instruments of interrelation of these three discreet states. Biorhythms provide consolidation of short-term adaptation effect in long-term behavior of biosystems and function as genetic systems having an after-effect. The result of empiric investigation seems to be important because it starts a new phase in chronobiology and concentrates the attention of researchers at studying

aftersound effects in three-component rhythmical system. In general, three-component aftersound may appear as a result of interrelations of three comparatively independent rhythmical processes, that is: human biorhythms, environmental natural rhythms (barometric, heo-heliomagnetic etc.), and also artificial rhythms, generated by industrial plants. In anthropogenic ecosystems in the condition of industrial transformation of environment the problem of phenotypic variability, after-effect persistence, inheritance of gained features and forming of bio-geo-industrial aftersound becomes current and turns from theoretically possible to practically realizable.

#### **References:**

1. Talalaeva G.V. et al. Radiation safety: science and practice journal PU “Mayak” 2003. N4. P.55-72.
2. Talalaeva G.V. et al. SNC bulletin: scientific and technical periodical journal. Curchatov, 2004. Issue 4 (20). P. 38-47.
3. Talalaeva G.V. Time, radiation and technogenesis: biological rhythms of industrial regions residents. Yekaterinburg: The Urals University Publishing house, 2006. 234p.
4. Talalaeva G.V., Khokhutkin I.M. Ecological and Economy effectiveness of environmental management at the present stage of the Urals and Siberian region development: Scientific and Practice conference materials. Omsk: "Science" Publishing house, 2006. p. 110-113.

## DETERMINATION OF THE GENETIC STRUCTURE OF REMNANT *MORUS BONINENSIS* KOIDZ. TREES TO ESTABLISH A CONSERVATION PROGRAM ON THE BONIN ISLANDS, JAPAN

Tani N.<sup>1</sup>, Yoshimaru H.<sup>1</sup>, Kawahara T.<sup>2</sup>, Hoshi Y.<sup>3</sup>, Nobushima F.<sup>3</sup>, Yasui T.<sup>3</sup>

<sup>1</sup>Department of Forest Genetics, Forestry and Forest Products Research Institute, Matsunosato, Tsukuba, Ibaraki 305–8687 Japan

<sup>2</sup>Hokkaido Research Center, Forestry and Forest Products Research Institute, Hitsujigaoka, Sapporo 062–8516 Japan

<sup>3</sup>Non-profit Organization for Research of Wild Organisms in Ogasawara, Chichi-jima, Ogasawara, Tokyo 100–2101 Japan

---

*Morus boninensis*, is an endemic plant of the Bonin (Ogasawara) Islands of Japan and is categorized as "critically endangered" in the Japanese red data book. However, little information is available about its ecological, evolutionary and genetic status, despite the urgent need for guidelines for the conservation of the species. Therefore, we adopted Moritz's MU concept, based on the species' current genetic structure, to define management units and to select mother tree candidates for seed orchards.

Nearly all individuals of the species were genotyped on the basis of seven microsatellite markers. Genetic diversity levels in putative natural populations were higher than in putative man-made populations with the exception of those on Otouto-jima Island. This is because a limited number of maternal trees are likely to have been used for seed collection to establish the man-made populations. A model-based clustering analysis clearly distinguished individuals into nine clusters, with a large difference in genetic composition between the population on Otouto-jima Island, the putative natural populations and the putative man-made populations. The Otouto-jima population appeared to be genetically differentiated from the others; a finding that was also supported by pairwise  $F_{ST}$  and  $R_{ST}$  analysis. Although multiple clusters were detected in the putative man-made populations, the pattern of genetic diversity was monotonous in comparison to the natural populations.

The genotyping by microsatellite markers revealed strong genetic structures. Typically, artificial propagation of this species has ignored the genetic structure, relying only on seeds from Otouto-jima for replanting on other islands, because of a problem with inter-specific hybridization on Chichi-jima and Haha-jima Islands. However, this study demonstrates that we should be taking into consideration the genetic structure of the species when designing a propagation program for the conservation of this species.

---

### Background

*Morus boninensis*, a plant native to the Bonin Islands (typical oceanic islands, located 1,000 km south of Tokyo, Japan), is only endemic to Otouto-jima, Chichi-jima and Haha-jima Islands; it is categorized as "critically endangered" in the Japanese Red Data Book [1]. This species is a typical case in which there is little information about the species, although guidelines are urgently needed to aid in its conservation. There are fewer than about 170 remaining trees and natural regeneration does not seem to be occurring at present (Yoshimaru et al. unpublished data). The reason for the

degradation of the species was intensive logging during the last quarter of the 19th century and the start of the 20th century (details described in [ 2 ]). Although *Morus boninensis* used to be one of the main species constituting the canopy in the moist tall forest on the Bonin Islands, some invasive trees, mainly *Bischofia javanica*, have replaced it in recent years [3-5]. In our field observations, seedling recruitment has not been observed since 1995. Yoshimaru et al. (unpublished data) estimated that the mortality rate of the mature individuals is between 0.56% and 3.56% per year in each population. Furthermore, hybridization with

the introduced species, *M. acidosa*, has been observed and has been confirmed by molecular marker analysis [ 2 ]. To promote the propagation of the next generation, selection of mother trees should be considered to maximize evolutionary success based on the concept of the Evolutionary Significant Unit (ESU, [ 6 ]). To achieve this, it is best practice to define ESUs based on genetic as well as ecological information. However, there is no ecological information about the species. Furthermore, the Bonin Islands are a typical example of the changing balance in Japan between biodiversity and single-minded development, between the desire to conserve native species and the desire to satisfy human desires, and between the modesty and creativity of local peoples and the arrogance and insensitivity inherent in massive public works funding[7]. Therefore, it is urgent that guidelines for conducting *ex situ* conservation and promoting the propagation of individuals for the next generation are put in place. One proposal by Moritz [8] was that the population ESU should be defined by the reciprocal monophyletic relationship based on mtDNA alleles and significant divergence of allele frequencies at nuclear loci (Moritz's Management unit, MU). Although Crandall et al [6] identified several conceptual and practical problems with the effectiveness of the use of a historical population structure, as defined by molecular genetic techniques, the concept has been adopted in various applied studies of animals to define conservation units based on ESUs [9-11]. Because of the pressing nature of our work, we have adopted Moritz's MU concept to define management units and aid in the selection of mother tree candidates for the seed orchards. This is based on the current genetic structure, since only genetic information is available at present. In this paper, we present a description of the current genetic structure of the species, genetic differentiation between populations and kinship within clustered individuals based on microsatellite markers.

These data can be used to establish a conservation program for the species.

### Results

Genetic variation within the operational populations

In total, 164 remnant trees were genotyped (data from two trees were missing). Based on their geographic distribution, these individuals were assigned to one of the six operational populations (Table 1 , Fig. 1). Maximum (21) and minimum (8) numbers of alleles were detected at *Mos0008* and *Mos0050* loci, respectively. Although alleles with the highest frequency were common between the operational populations at three loci, the other four loci did not share the highest frequency alleles between the operational populations (Fig. 2). The genetic variation within populations indicated by population genetic statistics that are not affected by population size, such as allelic richness ( $A_i$ ), observed and expected heterozygosity ( $H_o$  and  $H_e$ ), are responsible for the highest values in the KWK and SKM populations (Table 2 ). In contrast, the CCJ population exhibited the smallest amount of within population genetic variation when these statistics were considered. The difference between the largest and smallest amounts of genetic variation was, however, not large, indicating that these operational populations retain a similar level of genetic variation with some fluctuation. We observed significant deviation between the fixation indices of the CCJ, IGM and LPS populations when double reduction was not considered. An excess of homozygotes was observed at two loci in the CCJ population. The IGM and LPS populations exhibited an excess of heterozygotes at all significant loci, with the exception of *Mos0288* in the LPS population. All statistically significant deviation of the fixation indices indicates heterozygote excess if we assume that maximum double reduction occurred (Table 3 ).

Genetic differentiation among the operational populations

Global  $F$ -statistics indicate that there is highly significant population differentiation between populations at all microsatellite loci. However, Global  $R$ -statistics based on the stepwise mutation model showed that significant population differentiation occurred at five loci, but not at the two others. The significance level was much smaller in three of the five significant loci than those of  $F_{ST}$  (Table 4). The genetic

relationship between populations was determined by constructing a neighbour-joining tree based on pairwise  $F_{ST}$  and  $R_{ST}$  (Fig. 3). There was no difference in the topologies of the two phenograms, however, branch length was different. OTJ was the population most genetically separated from the others; this was supported by both pairwise  $F_{ST}$  and  $R_{ST}$ .

**Table 1.** Information of sampling sites and trees, such as background of population, location, tree size and vegetation

Background of the population		Latitude and Longitude		Elevation	Population density
OTJ	putative natural	N27° 10'46"-10'53"	E142° 11'18"-11'24"	33-90 m	Dense
CCJ	mixed <sup>1)</sup>	N27° 02'40"-06'14"	E142° 11'07"-14'00"	2-300 m	Sparse
KWK	mixed <sup>2)</sup>	N26° 39'32"-39'50"	E142° 08'59"-09'20"	188-334 m	Intermediate
IGM	unknown	N26° 39'38"-39'40"	E142° 08'58"-09'00"	155-172 m	Dense
SKM	putative natural	N26° 40'08"-40'25"	E142° 09'08"-08'37"	200-314 m	Sparse
LPS	putative man-made	N26° 40'52"-40'57"	E142° 09'48"-09'53"	174-183 m	Dense

Tree size (DBH)		Vegetation
OTJ	15-77 cm	Natural
CCJ	11-84 cm	Various type of vegetation
KWK	17-95 cm	Introduced species dominating
IGM	17-52 cm	Putative natural
SKM	20-119 cm	Natural
LPS	16-49 m	Second growth

1)The planted trees were sampled in northern civilization area and the middle part of the island, trees in the south part of the island supposed to be natural.

2)The planted trees are located in the lower elevation (to ca. 240 m), the natural trees are supposed to grow in the higher elevation area.

Both phenograms showed that IGM and LPS had similar genetic compositions. The branch length between KWK and CCJ was shorter in the phenogram based on  $R_{ST}$ , than in the one based on  $F_{ST}$ . It seems that KWK has a similar genetic composition to CCJ. However, SKM's genetic composition was different from KWK, as indicated by the long branch associated with SKM that diverges close to KWK in both the  $F_{ST}$  and  $R_{ST}$  phenograms.

Individual based analysis using the model-based clustering method

We performed model-based clustering in order to elucidate the population structure; we used multilocus micro-satellite genotypes, but excluded *Mos0157-2*, as it is closely linked to *Mos0157-1*. A model that

considered both admixture and uncorrelated allele frequency was adopted for the analysis. Our reasoning was that we had observed many stumps of *M. boninensis* and the species exhibits many characteristics, such as dioecism and anemophily, which might account for the admixture believed to have occurred in the past [12]. The highest posterior probability was obtained for nine clusters ( $K = 9$ ). All individuals growing in the OTJ operational population were assigned to a single cluster (represented in orange in Fig. 4), which was supported by 90% probability intervals for all but two individuals (912 and 932). Although in the IGM and LPS populations individuals were mainly assigned into three and four clusters, respectively, most individuals belonged to

two clusters represented by green and pink in the diagram. As well as the two main clusters, the LPS operational population contained four and five individuals, respectively, belonging to the black and yellow clusters. The individuals in the CCJ population were predominantly assigned into three clusters. The trees growing in the south part of Chichi-jima Island belonged to one particular cluster (purple), with the exception of TD1 and RJ1-8. Eight trees in RJ were separately assigned to three different clusters,

rather than the cluster represented by purple (Fig. 4). Two individuals from the northern part of Chichi-jima Island were assigned to a cluster containing three of the RJ individuals (shown in blue and red in Fig. 4). We observed a more complicated pattern of genetic composition, as determined by the clustering analysis, in the KWK and SKM operational populations of Haha-jima Island. Three main types of genetic composition were observed in the KWK population.

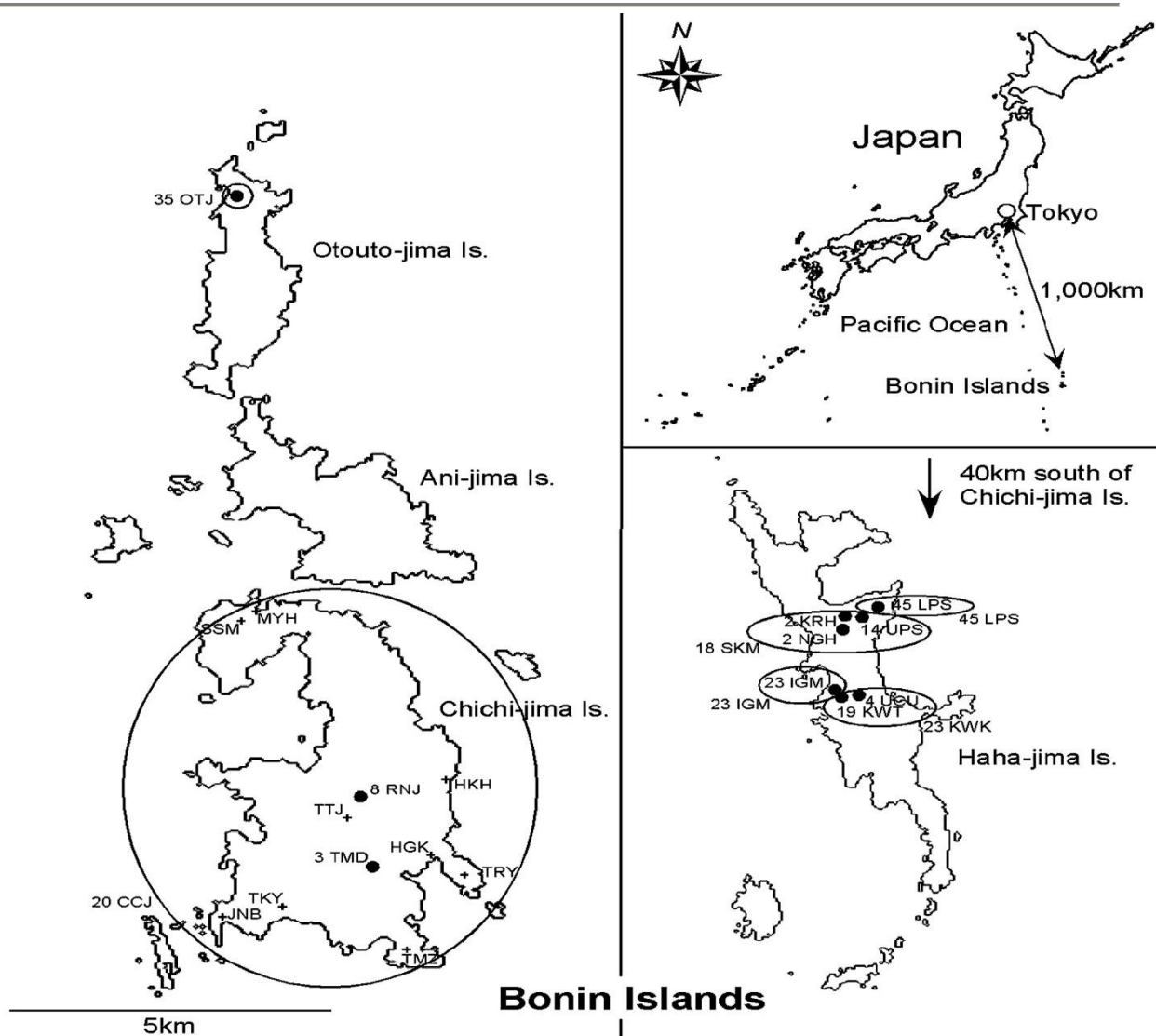

**Figure 1.** Location of the Bonin Islands and the location of each remnant tree of *M. boninensis*. The plus signs and black dots represent solitary trees and tree clumps, respectively. The number beside each black dot indicates the number of trees in that clump. The ellipses indicate the six operational populations.

Two of these were simply expressed by the green and yellow colours in Fig. 4. The genetic composition of another type was composed of three or four clusters (mainly grey, red, blue and purple) with more or less equal probability. The genetic composition of this type was similar to that of UPS in the SKM operational population. However, individuals in the UPS population were classified as belonging to the grey cluster at a higher probability than the individuals in KWK (Fig. 4).

Genetic diversity and kinship structure within the clusters

When we investigated whether attribution of individuals to the clusters was supported by a 90% confidence interval, 65 individuals could not be classified to a particular cluster at this level. The remaining 99 individuals were each classified to one of seven clusters with 90% certainty. Because four of these clusters did not contain enough individuals, we estimated the pairwise kinship values for only three clusters. Cluster 2 (pink in Fig. 4) was composed mostly of individuals from LPS, plus five individuals from IGM and two from KWT and NGH.

**Table 2.** Average genetic variation of each locus for five operational populations of *Morus boninensis*. Standard deviation of the mean is in parenthesis. Clusters 2, 6 and 7 are groups assigned by the model-based clustering analysis with a 90% confidence interval

Pop	N	A	A <sub>i</sub>	H <sub>o</sub>	Chromosome (Ce)		Chromatid (Cd)	
					H <sub>e</sub> (Ce)	H <sub>e</sub> (Cd)		
OTJ	35	6.429 (2.760)	2.523 (0.447)	0.659 (0.161)	0.620 (0.151)	0.579 (0.141)		
CCJ	20	7.286 (2.752)	2.429 (0.346)	0.630 (0.129)	0.674 (0.136)	0.629 (0.127)		
KWK	23	8.000 (2.380)	2.758 (0.252)	0.732 (0.085)	0.731 (0.084)	0.682 (0.079)		
IGM	23	6.571 (1.618)	2.708 (0.451)	0.712 (0.128)	0.681 (0.117)	0.636 (0.109)		
SKM	18	7.571 (1.718)	2.701 (0.187)	0.712 (0.057)	0.735 (0.065)	0.686 (0.060)		
LPS	45	8.143 (2.035)	2.589 (0.520)	0.669 (0.166)	0.661 (0.137)	0.645 (0.127)		
Cluster 2	19	4.571 (0.976)	2.709 (0.625)	0.710 (0.207)	0.639 (0.158)	0.597 (0.147)		
Cluster 6	33	6.000 (2.582)	2.524 (0.440)	0.661 (0.158)	0.616 (0.146)	0.575 (0.136)		
Cluster 7	35	4.714 (0.756)	2.666 (0.583)	0.695 (0.186)	0.634 (0.155)	0.592 (0.145)		

Cluster 6 (orange in Fig. 4) comprised all the individuals in the OTJ population, although two of them were not supported by the 90% confidence interval. Cluster 7 (green in Fig. 4) contained 19 individuals from LPS, 11 individuals from IGM, four individuals from KWT and a single individual from UPS. The amounts of genetic diversity were estimated for these clusters. In general, there were fewer alleles within the clusters than within the operational populations. However, the clusters retained almost the same levels of the observed heterozygosity as found in the operational populations. We estimated pairwise kinship between individuals of each of the clusters, two operational populations

(CCJ; mixed background of the population and SKM; putative natural of it) and all individuals using Loiselle et al.'s formula [13]. The kinships between all individuals were normally distributed, with a mean and standard deviation of nearly zero and 0.0674, respectively. Although the pairwise kinships of three clusters were almost normally distributed, their means were significantly different from zero. Maximum and minimum values of the means were 0.1003 and 0.0600 in clusters 6 and 7, respectively. Although numbers of pairs for CCJ and SKM were relatively fewer than those of the clusters, their means were not significantly different from zero (Fig. 5).

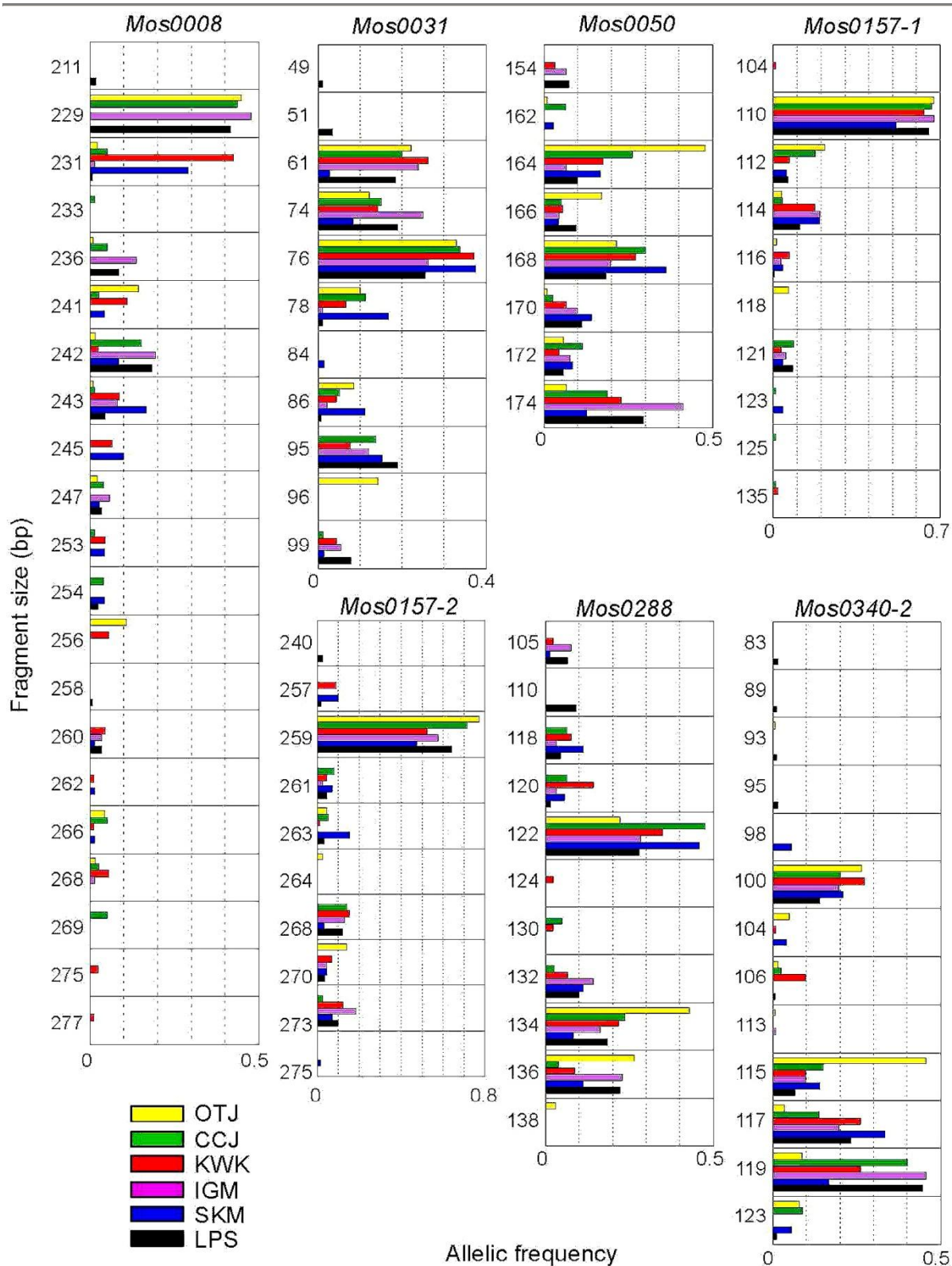

Figure 2. The distribution of alleles of each population for the seven microsatellite loci.

**Table 3.** Fixation indices for five operational populations of *Morus boninensis*, with and without double reduction. Clusters 2, 6 and 7 are groups assigned by the model-based clustering analysis with a 90% confidence interval

Locus	F (Chromosome, Ce)								
	OTJ	CCJ	KWK	IGM	SKM	LPS	Cluster 2	Cluster 6	Cluster 7
<i>Mos0008</i>	-0.037	0.178* <sup>1</sup>	0.001	-0.027	0.144	0.107	-0.090	-0.043	-0.049
<i>Mos0031</i>	-0.006	-0.003	0.029	-0.034	-0.029	-0.001	-0.104	-0.020	-0.125
<i>Mos0050</i>	-0.128	0.152*	0.049	-0.066	0.023	-0.082*	-0.157*	-0.137	-0.125*
<i>Mos157-1</i>	-0.043	-0.024	-0.018	-0.042	-0.046	0.070	-0.077	-0.048	-0.072
<i>Mos157-2</i>	-0.077	0.113	-0.012	-0.102	0.100	0.129	0.066	-0.077	-0.110*
<i>Mos0288</i>	-0.043	-0.041	-0.060	-0.091**	-0.006	0.046***	-0.164*	-0.060	-0.138***
<i>Mos340-2</i>	-0.113	0.067	-0.002	0.044	0.018	0.012	-0.139*	-0.118	-0.015
Average	-0.063	0.066	-1.000	-0.046	0.032	0.032	-0.110	-0.072	-0.095
S. D.	0.032	0.063	0.027	0.034	0.052	0.048	0.052	0.031	0.039

Locus	F (Chromatid, Cd)								
	OTJ	CCJ	KWK	IGM	SKM	LPS	Cluster 2	Cluster 6	Cluster 7
<i>Mos0008</i>	-0.111	0.119	-0.071	-0.101	0.082	0.043	-0.168	-0.118	-0.123
<i>Mos0031</i>	-0.078	-0.075	-0.040	-0.108	-0.103	-0.073	-0.183*	-0.093	-0.205***
<i>Mos0050</i>	-0.208*	0.092	-0.019	-0.143	-0.046	-0.160***	-0.240***	-0.218*	-0.205***
<i>Mos157-1</i>	-0.117	-0.097	-0.091	-0.117	-0.121*	0.003	-0.154	-0.123	-0.148
<i>Mos157-2</i>	-0.154	0.050	-0.084	-0.181	0.036	0.067	-0.001	-0.154	-0.189**
<i>Mos0288</i>	-0.117	-0.116	-0.136*	-0.168***	-0.078	-0.022**	-0.247**	-0.136	-0.219***
<i>Mos340-2</i>	-0.193*	0.000	-0.073	-0.025	-0.052	-0.058	-0.221**	-0.198*	-0.087
Average	-0.139	-0.001	-0.073	-0.120	-0.037	-0.037	-0.189	-0.149	-0.174
S. D.	0.035	0.061	0.027	0.036	0.050	0.054	0.062	0.035	0.047

<sup>1</sup>Asterisks indicate statistical significance of fixation index at (\*) 5%, (\*\*) 1% and (\*\*\*) 0.1%, based on goodness of fit between observed and expected genotype frequencies.

**Table 4.** The global  $F$  and  $R$  statistics for seven microsatellite loci

	$F_{IT}$	$F_{IS}$	$F_{ST}$	$R_{IT}$	$R_{IS}$	$R_{ST}$
All loci	0.0558***	0.0092	0.0470***	0.0924***	0.0645***	0.0298***
<i>Mos0008</i>	0.0873***	0.0653***	0.0235***	0.0507	0.0328	0.0185*
<i>Mos0031</i>	0.0282*	0.0025	0.0258***	0.1151***	0.1077**	0.0083
<i>Mos0050</i>	0.0401**	-0.0260*	0.0644***	-0.0188	-0.0878**	0.0634***
<i>Mos0157-1</i>	0.0232	-0.0025	0.0256***	0.0319	0.0268	0.0052
<i>Mos0157-2</i>	0.0798***	0.0407*	0.0408***	0.0632*	0.0373	0.0268**
<i>Mos0288</i>	0.0378**	-0.0139	0.0510***	0.1368***	0.0436	0.0975***
<i>Mos0340-2</i>	0.0931***	0.0065	0.0872***	0.1375***	0.1208***	0.0190*

<sup>1</sup>Asterisks indicate statistical significance at (\*) 5%, (\*\*) 1% and (\*\*\*) 0.1%, based on permutation test at 20,000 times

## Discussion

### *Genetic diversity within populations*

The model-based clustering method demonstrated that the genetic structure of the *M. boninensis* remnant trees did not correspond perfectly to the operational populations based on geographical distribution (Fig. 4). Although the OTJ operational population did coincide with the model based clustering, other operational

populations contained multiple clusters. However, in determining operational populations to be used in species conservation, there are two considerations of practical importance: 1) the convenience of conducting controlled crossing using trees in close physical proximity, whilst knowing their individual genetic relatedness; and 2) the ability to sample seed that may have been open pollinated from nearby paternal trees.



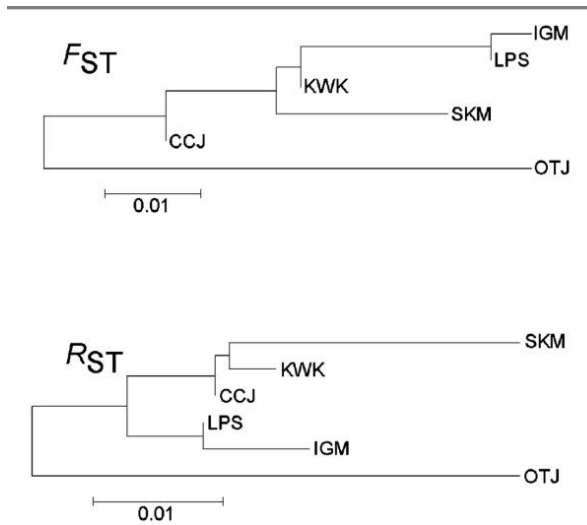

**Figure 3.** Neighbour-joining trees based on pair-wise  $F_{ST}$  and  $R_{ST}$  among operational populations of *M. boninensis*.

Therefore, it is important to understand the genetic composition at two levels: the operational population and the individual level. The genetic diversity levels in OTJ and CCJ were lower than in the other populations (Table 2 ). Although the OTJ population contains the secondly largest number of trees of all the operational populations, the genetic composition of each tree is very similar, as demonstrated by the model-based clustering (Fig. 4). This might be the result of a founding event, with a small number of maternal trees having produced the seed to establish the extant OTJ population. However, the low genetic diversity in the CCJ population is different. Four different genetic groups were identified in the CCJ population by model-based clustering analysis. Out of the four genetic groups, some of the trees comprising three of them (blue/red, yellow and green in Fig 4) are located in the northern part of Chichi-jima Island. This is an area inhabited by immigrant people. Trees in these same genetic groups were also present in KWK on Haha-jima Island. Therefore, these trees in CCJ were probably planted by people using seed sources from Haha-jima Island. In

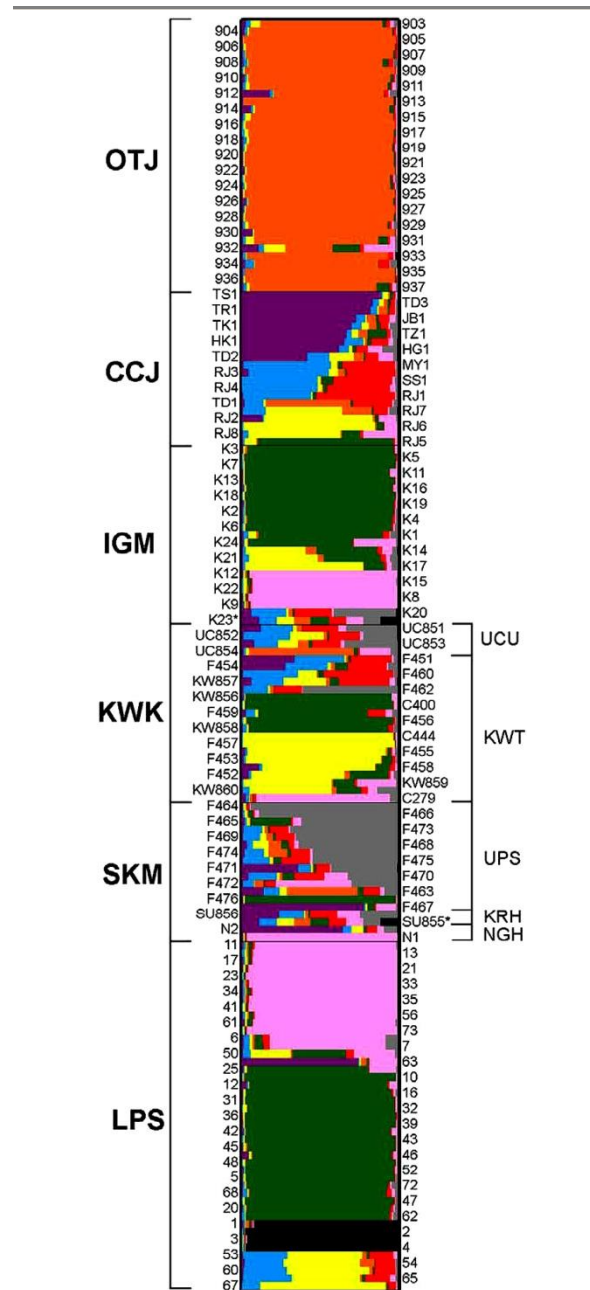

**Figure 4.** Bar plots of estimates of membership coefficient ( $Q$ ) for each individual for the inferred clusters ( $K = 9$ ) with maximum log-likelihood probability. Bar colours and lengths represent inferred clusters and  $Q$ , respectively.

contrast, the vegetation of the south of Chichijima is, to date, well preserved although there was some disturbance during World War II. These trees have retained their endemic genetic composition (purple in Fig. 4 ) on Chichi-jima Island, which probably

represents the native genetic composition of the species here. We only found nine remnant trees classified with the purple genetic composition in the CCJ population. Although the expected heterozygosity level of the nine remnant trees was smaller than that of CCJ (0.628 vs. 0.674), their allelic richness exceeded that of CCJ (2.476 vs. 2.429). This might be because a limited number of maternal trees were used as the seed source for planting the trees in the northern part of Chichi-jima Island, or because of bi-parental inbreeding of parent trees of this population.

On Haha-jima Island, we observed a similar pattern of genetic diversity as for the CCJ population. Trees on Hahajima Island were divided into four operational populations. One of the current authors (Y. Hoshi) remembered that the species had been grown in plantations on this Island. He recollected that part of KWK and LPS were planted by humans. Although the origin of the IGM population was not clear, the small, relatively uniform trees in IGM are distributed in quite a small area. This might indicate that, whilst these trees were not planted, they are the result of simultaneous regeneration from a few maternal trees, such as those of an original plantation. The amounts of within population genetic diversity of plantation trees (LPS) and IGM were lower than those of SKM and KWK.

According to the model-based clustering, we identified a similar pattern of genetic composition between the planted populations (part of KWK and LPS) and IGM – the clusters represented by mostly green and pink colours (Fig. 4). This might also indicate an origin from a limited number of maternal trees or bi-parental inbreeding. In contrast, the rest of the trees in the KWK and SKM populations exhibited a complicated genetic composition, and the SKM population contained the highest amount of genetic diversity of all the operational populations, despite having the smallest

sample size. In terms of genetic diversity and size of tree (data not shown), most trees in the SKM population and part of the KWK population are likely to be natural remnants.

The evidence of population bottlenecks and inbreeding

The individuals in the SKM population exhibited many components of different clusters (Fig. 4). As a result of its genetic characteristics, size of trees and vegetation pattern on the Islands, we deduced that this population is the closest to being natural. When we compared the genetic diversity level between the OTJ (almost equivalent to cluster 6) and SKM populations, the number of alleles, as well as the observed and expected heterozygosity was lower in the former. According to one theoretical study, the amount of reduction in heterozygosity depends not only on the "bottleneck" size but also on the rate of population growth after passing through the bottleneck, while the loss of alleles largely depends on the size of the "bottleneck" [ 14 ]. If the SKM population produced many generations after the bottleneck event, the heterozygosity level would be reduced. However, we have assumed that the SKM population produced few generations after population decline, because *M. boninensis* is known to be an extremely long-lived woody species [12]. Although the SKM population has maintained a high level of genetic diversity to date, the decline in genetic diversity in OTJ might be the result of bottleneck events, such as much severe logging, long-term population decline, or catastrophic population destruction.

When we estimated the pairwise kinships between individuals within a cluster and compared their average between clusters, the difference in average pairwise kin-ships between cluster 6 and all individuals was significant (Fig. 5). This meant that bi-parental inbreeding may have occurred during the bottleneck event in the OTJ population.

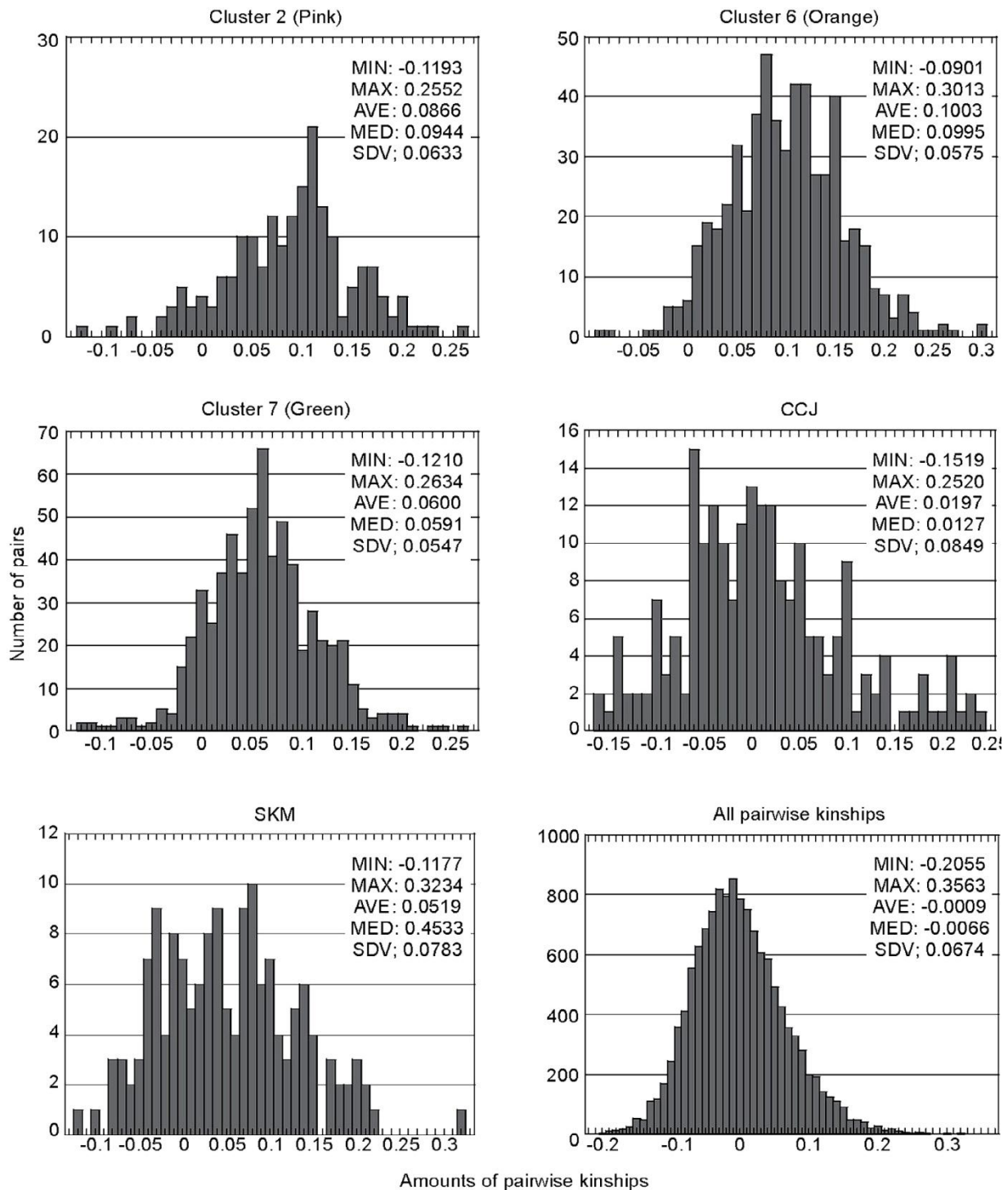

**Figure 5.** Distribution of the pairwise kinship coefficient between individuals supported by 90% probability intervals of Q within each cluster. Clusters 2, 6 and 7 correspond to the pink, orange and green clusters shown in Figure 4. MIN, MAX, AVE, MED and SDV represent minimum value, maximum value, mean, median and standard deviation, respectively, for each dataset.

However, the level of inbreeding was, supposedly, not strong, although expression of strong inbreeding depression for the

species may have been masked by mass mortality of inbred individuals at the seedling stage. This speculation is also supported by

the non-significant and negative fixation indices in cluster 6 and OTJ (Table 3). In contrast, potentially man-made populations, such as parts of KWK and LPS, and IGM, contained multiple clusters.

However, most individuals within these populations were classified into two main clusters (green and pink), supported by the 90% confidence interval in the model-based clustering analysis (Fig. 4). Furthermore, we detected higher pairwise kinship values within clusters (green and pink) than those for all pairs of individuals (Fig. 5). This could be the consequence of a limited number of maternal trees producing the seeds from which the man-made populations were propagated. In contrast, although the mean of the pairwise kinship of SKM was somewhat high value, the mean of pairwise kinship of the putative natural populations and mixed background population, SKM and CCJ, is not significantly different from zero. This suggests that these populations might not have experienced intensive bi-parental inbreeding, as occurred in the putative man-made populations. If we collect seed from a few mother trees for the propagation of the next generation, even open pollination will potentially cause bi-parental inbreeding and a decline in the genetic diversity of the new generation. Therefore, it is very important to construct seed orchards using clones of trees from natural populations and/or to perform controlled crossing between them. Furthermore, some pairs in SKM population represented high level of pairwise kinships between them, which implied that we must consider selection of parental trees to construct seed orchards and combinations of parental trees for control crossing even if parental trees are only selected from the natural populations

Establishment of conservation units and a propagation program

*Ex situ* conservation would seem to be necessary to conserve *M. boninensis*, because it is difficult to obtain seeds free of hybridization with *M. accidosa*. The

exception is the OTJ population [ 2 ]. In addition, seedling establishment is extremely rare because of the competition with introduced alien species, such as *Bischofia javanica* [ 5 ]. Therefore, selection of pure *M. boninensis* seedlings, controlled crossing and *ex situ* conservation are all necessary to ensure propagation of the species. To achieve this, we must consider Moritz's management units in order to select appropriate mother trees and we must undertake controlled crossing to obtain seed sources for propagation. In terms of genetic diversity, there was a large difference between the putative natural populations, with the exception of OTJ and IGM (south of CCJ, a part of KWK, most of SKM) and putative plantation trees. According to the model-based clustering analysis, planted individuals are classified into two main clusters, green and pink. This genetic differentiation, which is supported by the model-based clustering, should be used in selecting the MUs. We were able to identify at least seven main MUs for *M. bon-inensis*, which were OTJ, natural trees in CCJ, natural trees in KWK, SKM, man-made trees in CCJ and KWK and two major clusters including individuals in IGM and LPS (Green and Pink). Natural populations retained many elements of the different clusters. On the other hand, most of the plantation trees were simply classified into a single cluster. Hence, natural individuals were prime candidates for use as maternal trees in controlled crossing and *ex situ* conservation by grafting. According to analyses of pair-wise  $F_{ST}$  and  $R_{ST}$  and the model-based clustering, we should avoid controlled crossing and instead should establish new seed orchards by open pollination of individuals from different clusters. To date, the OTJ population has been the only one to produce pure *M. boninensis* seeds. These seeds, therefore, have been the only ones used for propagation. There is a hybridization problem with the introduced species in the KWK and SKM populations. Because the

MU of OTJ is definitely different from the other natural populations, we need to independently conduct controlled crosses or *ex situ* conservation (and subsequently develop seed orchards) within each cluster. Only then will propagated seedlings be available to use for propagation of the species in the forest according to the MUs identified in this study.

#### Conclusion

Genotyping using microsatellite markers revealed that the pattern of genetic variation was different between the OTJ population, the north CCJ putative man-made population, the south CCJ putative natural population, the natural population in Haha-jima (most of SKM and a part of KWK), IGM and the man-made population in Haha-jima (a part of KWK and LPS). These differences should guide the selection of the MUs. The putative natural populations exhibited higher genetic diversity than those of the man-made populations, IGM and OTJ. These are, therefore, important genetic resources for the propagation of a new generation. To date, propagation of the species has ignored its genetic structure by relying only on seeds from the OTJ population, even for planting on the other islands. This has been because of the interspecific hybridization problem on Chichi-jima and Haha-jima Islands. However, this study has demonstrated the high level of genetic differentiation within the species. This needs to be considered with respect to any propagation program aimed at conserving the evolutionary range of the species.

#### Methods

##### Field survey and collection of samples

Between 1998 and 2002, we conducted a field survey to find the unknown remnant trees of *M. boninensis*. Summary of field survey concerning with background of each population, location, tree size and vegetation was shown in Table 1. Identification of true *M. boninensis* or hybrids between *M. boninensis* and *M. acidosa* was conducted,

following sampling, using the three SCAR markers [ 2 ]. This allowed us to exclude hybrids from subsequent population genetic analyses. To date, we have found and collected petioles from 35 trees on Otouto-jima Island (OTJ), 20 trees on Chichi-jima Island (CCJ) and 109 trees on Haha-jima Island (Yoshimaru et al. unpublished data). Four areas were recognized in terms of their geography and the distributional density of the remnant trees on Haha-jima Island. Therefore, we assumed that these four geographical areas would be operational populations. We gave them the names: Iguma-wan (IGM), Kuwanokiyama (KWK), Sekimon (SKM) and lower plateau of Sekimon (LPS). We were able to recognize some sub-groups of trees within two operational populations: KWK and SKM. KWK contained Uchu-sawa (UCU) and Kuwanoki-yama test field (KWT). SKM contained the upper plateau of Sekimon (UPS), Kiri-hama (KRH) and Naga-hama (NGH). However, we did not deal with these tree clusters as operational populations because they contained relatively few individuals. Thus, 23, 23, 18 and 45 remnant trees were identified and sampled in the IGM, KWK, SKM and LPS operational populations, respectively. The petioles from these trees were stored at -20°C until the DNA was extracted.

##### DNA preparation and genotyping of microsatellite loci

DNA was extracted from 100 mg of the petioles of each of the sampled remnant trees using a DNeasy plant-mini Kit (QIAGEN, Hilden, Germany) and following the manufacturer's instructions. The genomic DNA concentration was adjusted to 5 ng/μL by dilution after measuring the concentration of extracted DNA using a spectrophotometer (Amersham Biosciences, Little Chalfont, UK). For all trees, the genotypes of seven microsatellite markers were assigned according to the procedure described by Tani et al. [ 15 ]. Because *M. boninensis* is a putative autotetraploid species, we

determined the allele copy number of partial heterozygotes based on dosage of electrophoretogram peaks.

#### Operational populations based analyses

We based the composition of the six operational populations on geographical distribution and individual tree aggregations. For these we calculated population genetic statistics as follows: the number of alleles ( $A$ ); the average number of alleles per individual ( $A_i$ ); the average number of four allele genotypes ( $G$ ); and observed heterozygosity ( $H_o$ ). These were obtained for each locus using the program AUTOTET [ 16 ]. Two types of expected heterozygosities ( $H_e$ ) and fixation indices ( $F_{is}$ ) were calculated under two assumptions: 1) random mating and random chromosome segregation (RceS); and 2) random mating and some level of chromatid segregation (RcdS), for which we selected the maximum theoretical double reduction rate,  $\alpha = 1/7$  [ 17 - 19 ]. Using SPAGeDi software,  $F$ -statistics and  $R$ -statistics, based on the infinite allele model and the stepwise mutation model, respectively, were estimated in order to evaluate genetic diversity between the operational populations [ 20 - 22 ]. Random resampling of individuals was parmuteted at 20,000 times to obtain a confidence interval for the estimators of population differentiation and the inbreeding coefficient. The genetic relationships between the operational populations were elucidated using neighbor-joining trees based on pairwise  $F_{ST}$  and  $R_{ST}$ , with the aid of two software packages, Mega ver. 2.1 and SPAGeDi [ 20 , 23 , 24 ].

#### Individual based analyses

To identify any unknown population structure, we used a model-based clustering method implemented by the program Structure ver. 2.0. This estimated the number ( $K$ ) of clusters into which the sample data ( $X$ ) were fitted with posterior probability  $\Pr(X|K)$ , using a model with admixture and uncorrelated allele frequency [25]. We conducted  $10^6$  iterations following a burn-in

period of at least 30,000 iterations. The genotypes of the *Mos0157-2* locus were omitted from the data set because *Mos0157-2* was constructed from same sequence as *Mos0157-1*, and hence these loci were closely linked to each other.  $K$  provides only a rough guide for determining which models are consistent with the data. Therefore, we examined various  $K$  values, from 1 to 20, within the simulation, and searched for a suitable  $K$  value to maximise the posterior probability  $\Pr(X|K)$ . The Structure software estimates the proportion of ancestry ( $Q$  value) from each of the  $K$  clusters for each individual and the 90% probability intervals. Assignment of individuals into inferred populations was conducted using the  $Q$  values and their probability intervals. Only individuals supported by 90% probability intervals were assigned to each cluster. A kinship coefficient between individuals within a cluster was estimated using SPAGeDi software [13 , 20 ]. The amount of kinship within each cluster was estimated by comparing the probability of two individuals in a cluster having identical genes to the probability that two individuals chosen at random from all the samples are identical.

#### Authors' contributions

NT performed the sampling, molecular analyses, data interpretation, wrote the manuscript and was responsible for this study of *M. boninensis*. HY performed the sampling, constructed the database for the remnant trees and interpreted the data. TK performed the sampling and data interpretation. YH, FN and TY performed the survey of the remnant trees and the sampling. All authors read and approved the final manuscript.

#### Acknowledgements

The authors would like to thank N. Savory Jr. and N. Tanaka for information about remnant *M. boninensis* trees, I. Okochi for management of the project, C. Yamanaka and Y. Taguchi for laboratory assistance, H. Iwata for advice on data analysis and Y. Tsumura, S. L. Lee and two anonymous

reviewers for valuable comments on the manuscript. This research was partly supported by a grant to finance a 'Restoration study of the Ogasawara forest ecosystem due to exclusion of the effects of naturalized organ-isms' from the Japanese Ministry of the Environment.

### References:

1. Environment Agency of Japan: Threatened Wildlife of Japan -Red Data Book 2nd ed.-. Volume 8, Vascular Plants. Tokyo, Japan Wildlife Research Center; 2000.
2. Tani N, Kawahara T, Yoshimaru H, Hoshi Y: Development of SCAR markers distinguishing pure seedlings of the endangered species *Morus boninensis* from *M. boninensis* x *M. acidosia* hybrids for conservation in Bonin (Ogasawara) Islands. *Conserv Genet* 2003, 4(5):605-612.
3. Shimizu Y: Vegetation of Mt. Kuwanoki in the Bonin (Ogasawara) Islands with reference to the invasion of an introduced tree species *Bischofia javanica*. *Institute for Applied Geography, Komazawa University, Tokyo, Regional Views* 1988, 1:31-46.
4. Tanimoto T, Toyota T: Survivorship and growth of Akagi (*Bischofia javanica* BI) seedlings under the forest canopy and different temperature conditions. *Bulletin of the Forestry and Forest Products Research Institute* 1996, 370:1-19.
5. Yamashita N, Tanaka N, Hoshi Y, Kushima H, Kamo K: Seed and seedling demography of invasive and native trees of sub-tropical Pacific islands. *J Veg Sci* 2003, 14(1):15-24.
6. Crandall KA, Bininda-Emonds ORP, Mace GM, Wayne RK: Considering evolutionary processes in conservation biology. *Trends Ecol Evol* 2000, 15(7):290-295.
7. Guo N, McCormack G: Coming to terms with nature: development dilemmas on the Ogasawara Islands. *Japan Forum* 2001, 13(2):177-193.
8. Moritz C: Defining Evolutionarily-Significant-Units for Conservation. *Trends Ecol Evol* 1994, 9(10):373-375.
9. Douglas MR, Brunner PC: Biodiversity of Central Alpine Core-gonus (Salmoniformes): Impact of one-hundred years of management. *Ecol Appl* 2002, 12(1):154-172.
10. Hedrick PW, Parker KM, Lee RN: Using microsatellite and MHC variation to identify species, ESUs, and MUs in the endangered Sonoran topminnow. *Mol Ecol* 2001, 10(6):1399-1412.
11. Holland BS, Hadfield MG: Islands within an island: phylogeography and conservation genetics of the endangered Hawaiian tree snail *Achatinella mustelina*. *Mol Ecol* 2002, 11(3):365-375.
12. Yoshida K, Oka S: Ecological characteristics of *Morus boninensis* reconstructed from its remaining stumps in the Sekimon Region of Hahajima Island, Ogasawara (Bonin) Islands, northwestern Pacific. *Jpn J Histor Bot* 2000, 9(1):21-28.
13. Loiselle BA, Sork VL, Nason J, Graham C: Spatial Genetic-Structure of a Tropical Understory Shrub, *Psychotria officinalis* (Rubiaceae). *Am J Bot* 1995, 82(11):1420-1425.
14. Nei M, Maruyama T, Chakraborty R: Bottleneck Effect and Genetic-Variability in Populations. *Evolution* 1975, 29(1):1-10.
15. Tani N, Kawahara T, Yoshimaru H: Development and diversity of microsatellite markers for endangered species, *Morus boninensis* Koidz., to establish conservation program. *Mol Ecol Notes* 2005, 5(2):398-400.
16. Thrall PH, Young A: AUTOTET: A program for analysis of autotetraploid genotypic data. *J Hered* 2000, 91(4):348-349.
17. Bever JD, Felber F: The theoretical population genetics of autopolyploidy. In *Oxford surveys in evolutionary biology* Edited by: Antonovics J, Futuyma D. New York, Oxford University Press; 1992:185-217.
18. Geiringer H: Chromatid Segregation of Tetraploids and Hexaploids. *Genetics* 1949, 34(6):665-684.
19. Haldane JBS: Theoretical genetics of autopolyploids. *J Genet* 1930, 22:359-372.
20. Hardy OJ, Vekemans X: SPAGEDI: a versatile computer program to analyse spatial genetic structure at the individual or population levels. *Mol Ecol Notes* 2002, 2(4):618-620.
21. Rousset F: Equilibrium values of measures of population subdivision for stepwise mutation processes. *Genetics* 1996, 142(4):1357-1362.
22. Slatkin M: A Measure of Population Subdivision Based on Microsatellite Allele Frequencies. *Genetics* 1995, 139(1):457-462.
23. Kumar S, Tamura K, Jakobsen IB, Nei M: MEGA2: molecular evolutionary genetics analysis software. *Bioinformatics* 2001, 17(12):1244-1245.
24. Saitou N, Nei M: The Neighbor-Joining Method - a New Method for Reconstructing Phylogenetic Trees. *Mol Biol Evol* 1987, 4(4):406-425.
25. Pritchard JK, Stephens M, Donnelly P: Inference of population structure using multilocus genotype data. *Genetics* 2000, 155(2):945-959.

## BK VIRUS ASSOCIATED MENINGOENCEPHALITIS IN AN AIDS PATIENT TREATED WITH HAART

Vidal J. E.<sup>1,5</sup>, Fink M. C.<sup>6</sup>, Cedeno-Laurent F.<sup>10</sup>, Delbue S.<sup>8</sup>, Ferrante P.<sup>7,8</sup>  
 Dauar R. F.<sup>3</sup>, Filho F. B.<sup>1</sup>, Nogueira R. S.<sup>1</sup>, Calore E. E.<sup>4</sup>, Pannuti C. S.<sup>6</sup>  
 Trujillo J. R.<sup>10</sup>, Penalva de Oliveira A. C.<sup>2,9</sup>

<sup>1</sup>Department of Infectious Diseases, Emilio Ribas Institute of Infectious Diseases, Sao Paulo, Brazil

<sup>2</sup>Department of Neurology, Emilio Ribas Institute of Infectious Diseases Sao Paulo, Brazil

<sup>3</sup>Department of Neurosurgery, Emilio Ribas Institute of Infectious Diseases, Sao Paulo, Brazil

<sup>4</sup>Department of Pathology, Emilio Ribas Institute of Infectious Diseases Sao Paulo, Brazil

<sup>5</sup>Department of Infectious Diseases, Sao Paulo University, Sao Paulo, Brazil,

<sup>6</sup>Laboratory of Virology of the Institute of Tropical Medicine Sao Paulo University, Brazil,

<sup>7</sup>Laboratory of Molecular Medicine and Biotechnology of Don C. Gnocchi Foundation ONLUS, IRCCS, Milan, Italy,

<sup>8</sup>Department of Technology and Biomed Sciences University of Milan, Italy,

<sup>9</sup>Clinical Research Unit on Human Retrovirology, University of Campinas Sao Paulo, Brazil and

<sup>10</sup>Institute of Human Virology, University of Maryland Biotechnology Institute, UMD, USA

---

A severely immune-suppressed AIDS patient was suspected of suffering from BK virus (BKV) meningoencephalitis, after being studied for common causes of neurological complications of co-infectious origin. Polymerase chain reaction (PCR) and sequence analysis of cerebrospinal fluid and brain samples, confirmed the presence of BKV. His clinical condition improved along with the regression of brain lesions, after modifications on his antiretroviral regime. Five months after discharge, the patient was readmitted because of frequent headaches, and a marked inflammatory reaction was evidenced by a new magnetic resonance imaging (MRI). The symptoms paralleled a rising CD4<sup>+</sup> lymphocyte count, and immune reconstitution syndrome was suspected. This is the first non-postmortem report of BKV meningoencephalitis in an AIDS patient, showing clinical and radiographic improvement solely under HAART.

---

### Background

Neurological complications associated with HIV-1/AIDS are being recognized with a high frequency that parallels the increased number of AIDS cases [1]. Since the introduction of HAART, morbidity and mortality secondary to primary and secondary neurological opportunistic diseases in HIV-

1/AIDS patients have significantly decreased [ 2, 3 ]. However, neurocognitive impairments continue to occur in high frequencies, even in countries, with a free and universal access program to HAART, such as Brazil [ 4].

Recently, atypical presentations of brain diseases, such as JC virus granule cell



neuronopathy, and those related to the reconstitution of the immune system after initiation of HAART have been reported in a growing basis [5-7]. These unusual neurological pictures in AIDS patients represent new diagnostic and therapeutic challenges [7,8].

BKV meningoencephalitis is a rare polyomaviral infection with fatal outcome when associated with AIDS [9-11]. The clinical picture is devastating, resulting in death from multi-organ failure [12]. Here, we describe the clinical course of an AIDS patient with presumed BKV meningoencephalitis who showed substantial improvement after modification of his HAART regime.

#### Case presentation

In April 2004, a 43-year-old HIV-1 positive heterosexual male was admitted to the hospital complaining of bilateral headache of moderate intensity accompanied by speech, gait and memory disturbances. HIV-1 infection was diagnosed in July 2003 after an episode of cryptococcal meningitis; with a documented CD4<sup>+</sup> lymphocyte count of 6 cells/mm<sup>3</sup>. His past medical history includes an episode of pancreatitis secondary to lopinavir/ritonavir (July, 2003), and an episode of tuberculous meningitis (October, 2003). On admission, antiretroviral medications included zidovudine, lamivudine, and efavirenz (antiretroviral scheme modified after pancreatitis in August, 2003). Other medications included: fluconazole, TMP-SMX, isoniazid, ofloxacin, ethambutol, and pyrazinamide (rifampin was discontinued and replaced by ethambutol and ofloxacin after a marked increase of hepatic enzymes in November, 2003).

Initial examination revealed mental confusion, dysarthria and ataxia. Baseline cranial CT scan showed two hypodense lesions with mass effect and no contrast enhancement in the left temporo-parietal and right occipito-parietal areas. His CD4<sup>+</sup> lymphocyte count was 37 cells/mm<sup>3</sup>, with an

undetectable viral load. Presumptive cerebral toxoplasmosis was diagnosed, and a treatment with sulphadiazine-pyrimetamine, folic acid, and dexamethasone was started. After 14 days of therapy, the patient's neurological status and CT scan findings remained unchanged. Analysis of the cerebrospinal fluid (CSF) obtained on day 14 after admission showed 12 leukocytes/mm<sup>3</sup> (79% lymphocytes, 10% monocytes), glucose of 46 mg/dl and a protein level of 146 mg/dl. Herpes simplex encephalitis was suspected, and acyclovir replaced the medications for toxoplasmosis. After a week on this therapeutic regime, the patient's neurological status remained unaltered, and PCR analysis of CSF was performed, resulting negative for all human herpes viruses, JCV, and for *Toxoplasma gondii*. Nevertheless, PCR for polyomavirus BKV resulted positive.

From this data, acyclovir and dexamethasone were discontinued, and the patient underwent MRI-guided stereotactic brain biopsy of the lesion found in the right occipital lobe. Intraoperative MRI findings were similar to those previously seen by CT scan (Figure 1A). Histopathological examination showed thickened leptomeninges with a lymphocytic infiltrate that extended perivascularly (Figure 2A). The underlying cortex showed mild astrogliosis with prominent hypertrophic nuclei and bi-nucleated forms (Figure 2 A). PCR examination of the brain tissue sample also showed the presence of BKV DNA in the absence of any other polyomaviruses (Figure 2C and 2 D). The patient was reclassified as with presumptive BKV subacute meningoencephalitis. His therapeutic regime included the replacement of efavirenz for atazanavir/ritonavir along with the administration of zidovudine/ lamivudine, leaving the patient exclusively with HAART. Urine analysis and renal function tests were performed, showing <10 leucocytes/field, undetectable red blood cells and proteins, a serum creatinine of 0.8 mg/dl, and a BUN of

16 mg/dl. These values, discarded the presence of renal and urinary abnormalities that are normally present in the context of BKV clinical infection. Four weeks after admission, neurological manifestations improved considerably, and the patient was discharged.

Five months after discharge, the patient complained of mild headaches. A new MRI reported improvement of the two lesions previously seen; however, new areas of increased signal intensity of the white matter appeared (Figure 1 B). Based on a rising CD4<sup>+</sup> lymphocyte count of 144 cells/mm<sup>3</sup>, and in the absence of any other co-infectious agent, "encephalopathy of unknown origin" secondary to immune reconstitution was suspected. We kept close follow-up without any other intervention, and the patient gradually recovered.

Seven months after discharge, MRI lesions and CD4<sup>+</sup> lymphocyte count further improved (Figure 1C.). Since then, and until May 2007, the patient has been in the same HAART regime, with no neurological complaints; his renal and liver function have always been unaltered, and his last CD4<sup>+</sup> lymphocyte count was of 336 cells/mm<sup>3</sup> with a viral load below 400 copies/ml.

### Methods

#### *Serum Hiv-1 viral load detection*

All quantifications of viral load were performed by real-time RT-PCR. The threshold of detection was 400 copies/ml.

#### *BKV and JCV DNA amplification from CSF samples*

PCR technique as described by Arthur *et. al.* [13] was used to amplify the T-antigen gene (173 bp) of both, BKV and JCV. To establish whether BK viral sequences inhibited the reaction, 10 µl of CSF sample were added to duplicate tubes containing the PCR mixture and polyomavirus cloned DNA. An amplification band of 173 bp was analyzed by 2% agarose gel electrophoresis and visualized by exposure to UV light after staining with ethidium bromide.

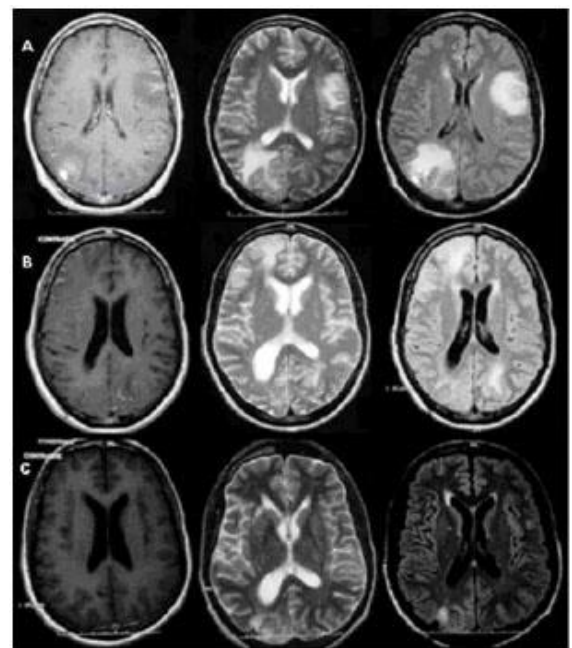

**Figure 1.** Panel A. Intraoperative brain images in April 2004. An axial T1-weighted image after gadolinium injection (left-hand side) shows lesions in the gray matter of the left temporo-parietal lobe and right occipital lobe (place of biopsy). These images show slight enhancement of the lesions particularly in the meninges and the presence of mass effect. An axial T2-weighted image (center) and a FLAIR image (right-hand side) show better details of the lesions. Panel B. Brain MRI images, 5 months after discharge. Axial T-1 weighted image after gadolinium injection (left-hand side) showed important improvement in gray matter lesions. However, images in T2-weighted (center), and FLAIR (right-hand side) showed presence of new high-signal-intensity lesions in the white matter of the right frontal lobe and left occipital lobe. A widening of the right ventricle compared to the figure in Panel A can be observed. Panel C. Brain MRI images, 7 months after discharge. Axial T-1 weighted image after gadolinium injection (left-hand side) shows normal appearance. Images in T2-weighted (center) and FLAIR (right-hand side) reveal regression of the white matter changes; however discrete widening of the right ventricle is still present.

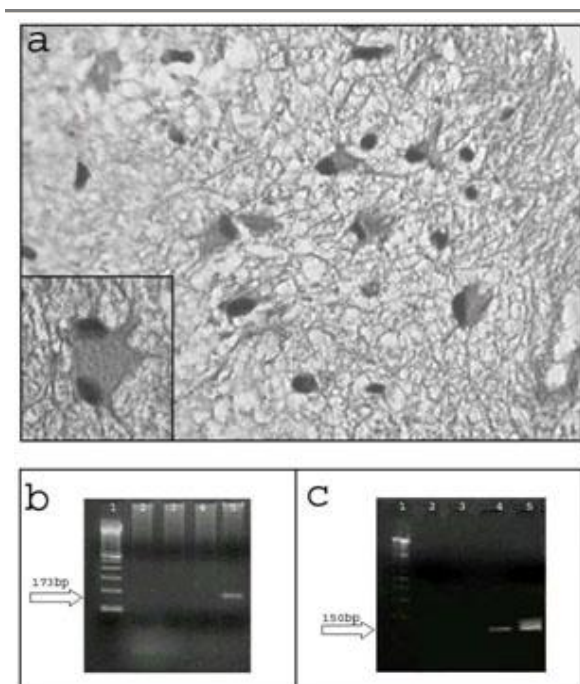

**Figure 2.** A) Representative section of the brain biopsy (H&E 40X) shows thickened leptomeninges with an infiltrate composed of lymphocytes and plasmacytes that extended perivascularly. Inset shows an astrocyte with prominent and hyper-chromatic nuclei. B) Electrophoresis on 2% agarose gel of BKV PCR products from CSF. Lane 1, Marker 100 bp; Lane 2, negative control of PCR; Lane 3, negative control of extraction; Lane 4, 250 ng DNA; Lane 5, positive control of PCR. C) Electrophoresis on 2% agarose gel of JCV PCR products from brain biopsy. Lane 1, Marker 100 bp; Lane 2, negative control of PCR; Lane 3, negative control of extraction; Lane 4, 1000 ng DNA; Lane 5, positive control of PCR.

Discriminating between JCV and BKV was performed by treatment of PCR products (10  $\mu$ l) with the restriction enzyme BamH1 (Invitrogen) and analyzed by electrophoresis on a 3% agarose gel.

#### **BKV and JCV DNA amplification from brain biopsy**

DNA was isolated twice from 25 mg of paraffin-embedded tissue using the DNeasy Tissue Kit (QIAGEN, USA). Negative control of extraction was carried out, using

water instead of lysed tissue sample. DNA amplification was carried out by seminested-PCR on different amount of DNA purified from paraffin-embedded biopsies. A 150 base pair fragment of the BKV LT-coding region was amplified using the outer primers Pep1 and Pep2 and the inner primers Pep1 and BKS (nt 4513–4529, Dunlop strain). Parameters for the 30 cycles of outer PCR were 95°C denaturation, 54°C annealing and 72°C elongation for 30 sec each, whereas for the inner PCR the annealing temperature was 52°C. Urine from a patient with "polyomavirus associated nephropathy" was used as positive control, while water as negative control. Amplification of the LT region of JCV DNA was carried out by nested-PCR on different amount of DNA, by using set of primers JC1 and JC2 (outer), Pep1 and Pep 2 (inner). Moreover, to discard contamination by other polyomavirus, we performed a western blot analysis with the antibody against JCV/SV40 Tag (94 kDa) and against actin (40 kDa) as a control. Our patient's sample came out negative for the former (data not shown).

#### **Sequence analysis**

PCR products were added to a mixture containing 4  $\mu$ l of *Ready Reaction Premix 2.5X*, 2  $\mu$ l of *BigDye Sequencing Applied Biosystems 5X* buffer, 3.2 pmol of either *forward or reverse primers*, and water up to a final volume of 20  $\mu$ l. The cycle sequencing was performed using the GeneAmp PCR System 9700, with the following protocol: initial denaturation at 96°C for 1', then 25 cycles with a first step at 96°C for 10", a second step at 50°C for 5" and the last rapid thermal ramp to 60°C for 4'. 5  $\mu$ l of the purified product underwent electrophoresis on an ABI PRISM 310 Genetic Analyzer. Sequence homology searches were performed using BLAST at NCBI (USA).

#### **Conclusion**

We report the first *in-vivo* case of BKV-associated meningoencephalitis in an AIDS patient who showed clinical

improvement and regression of brain lesions while on HAART.

BKV infection is generally a benign condition in immunocompetent patients, and the causative agent of "polyomavirus associated nephropathy" and hemorrhagic cystitis in immunocompromised individuals [ 12 , 14]. However, there is a growing body of evidence demonstrating its neurotropism [14-16]. Among AIDS patients, only 3 cases of BKV- meningoencephalitis have been described, and all of them reported post-mortem [ 9 -12 ].

Initially, the morphology of the lesions and the cytochemical profile of the CSF samples led us to empirically diagnose the patient with cerebral toxoplasmosis and herpes simplex encephalitis afterwards. However, the lack of response to treatment and the presence of BKV DNA in CSF samples and brain tissue led us to reclassify the patient as with BKV meningoencephalitis.

Compared to the other 3 cases reported, the presence of BKV DNA in the CSF is a common denominator of true neurological disease. As previously described, the detection of BKV genome in brain samples is unspecific, as it is normally present in 3%–6% of HIV-1 infected patient, even without neurological symptoms [17]. Our patient's histopathological description is identical to the ones previously reported, showing diffuse areas of increased signal [ 9, 11 ]. Progressive multifocal leukoencephalopathy was ruled out because of the normal morphology of oligodendrocytes. In terms of the radiological changes, our case is similar to the previous ones, showing areas of increased signal intensity of the periventricular white matter (MRI) [11]. Other descriptions include increased meningeal contrast enhancement along with increased meningeal thickness (MRI) [ 9 ], and marked internal hydrocephalus and periventricular lucencies (CT scan) [ 10 ]. None of the previous reports showed features

suggesting immune reconstitution inflammatory syndrome (IRIS).

Our main limitation to conclude that BKV is the causative agent of the neurological disorders is the lack of demonstration of the virus in the brain tissue sample, either by immunohistochemistry or by *in-situ* hybridization. Tissue samples extracted by stereotactic surgery are limited, and most of the times insufficient to run all diagnostic tests. These limitations were not faced in other reported cases, as all of these were done post-mortem.

Another important difference is the lack of renal/systemic involvement in our patient, when compared to the other cases previously reported. Our patient's renal work up included serial urinalysis and renal function tests that remained normal throughout the course of the disease (creatinine 0.8 mg/dl, BUN of 16 mg/dl, in April, 2004, creatinine of 0.9 mg/dl, BUN of 28 mg/dl in October, 2004.). As an outpatient his renal function has continued in the normal ranges (creatinine of 0.9 mg/dl, BUN of 40 mg/dl, May 2007). The containment of the disease was possibly related to a partial effect of HAART, similar to what has been reported for other AIDS-associated neurological complications in the post-HAART era, opening a broader spectrum of AIDS-associated neurocognitive disorders [18].

In this case, the change of atazanavir-ritonavir for efavirenz might have helped to reactivate the immune system, improving the symptoms and morphology of the lesions associated with BKV meningoencephalitis. The rationale of this change was based upon our previous experience and the results of an unpublished work describing the benefits of protease inhibitors in the restoration of the CD4 count when compared to non-nucleoside analogs (*Riddler SA, Haubrich R, DiRienzo G, et al. A prospective, randomized, phase III trial of NRTI-, PI-, and NNRTI-sparing regimens for initial treatment of HIV-1 infection: ACTG 5142.*

*Program and abstracts of the XVI International AIDS Conference; August 13–18, 2006; Toronto, Canada. Abstract THLB0204*). Unfortunately, the restoration of the immune system is not innocuous, and as previously described, deleterious effects are found in the context of polyomavirus infection, introduction of HAART, and a rising CD4<sup>+</sup> count [ 19]. Immune reconstitution inflammatory syndrome (IRIS), as the latter phenomenon is known, affects 15% to 45% of patients receiving HAART. CNS involvement has been reported to occur in the presence of tuberculosis (33%), cryptococcosis (4.2%–15.9%), JC virus (unknown frequency); being manifested radiologically as the extension or worsening of a previous condition or by the apparition of lesions that are enhanced by contrast, with or without involvement of the meninges and sometimes accompanied by hydrocephalus [ 6 ]. In our patient, the newly developed cerebral lesions and the headaches spontaneously resolved.

In conclusion, our report demonstrates that BKV might be the causative agent of meningoencephalitis in AIDS patients, and that this virus must be investigated in higher frequencies in HIV-1 positive patients with neurological manifestations now that its neurotropism has been better documented. In our patient, a previously reported life-threatening and disseminated disease progressed to a mild and focalized neurological condition in the presence of HAART.

#### **Competing interests**

The author(s) declare that they have no competing interests.

#### **Authors' contributions**

JEV was in charge of the inpatient/outpatient care, management collected and analyzed all the data, drafted the manuscript, and made critical intellectual contributions; MCF performed the PCR for BKV and JCV in CSF, and BKV sequence in CSF, and drafted the manuscript; FCD participated in the design and drafting of

manuscript, collected the data, and made critical intellectual contributions; SD performed the PCR for BKV and JCV in brain tissue, performed the western blot of cross-reactivity for SV40, JCV and BKV proteins, and drafted the manuscript; PF performed the PCR BKV and JCV in brain tissue, performed the western blot of cross-reactivity for SV40, JCV and BKV proteins, and drafted the manuscript; RD performed the stereotactic biopsy and made intellectual contributions to the manuscript; FBF was in charge of the inpatient management of the patient, and collected the data and analyzed it; RSN was in charge of the inpatient management of the patient, collected the data and analyzed it; EEC performed the morphological analysis and histopathological studies; CSP performed the PCR for BKV and JCV in CSF, and BKV sequence in CSF, and drafted the manuscript; JRT designed and drafted the manuscript, supervised the study, and made critical intellectual contributions; ACP was in charge of the inpatient/outpatient care, supervised the study, drafted the manuscript, analyzed the data, and made critical intellectual contributions.

#### **Acknowledgements**

José E. Vidal is supported by the Coordenação de Aperfeiçoamento de Pessoal de Nível Superior (CAPES) grant 001/0700/000186/2003. Pasquale Ferrante is supported by NIH grant MH068360-01. The authors thank to A.F. Tateno, M.C.A. Bernal, and J.E. Martins for their technical support. We are indebted to Drs. Walter Royal III and Anthony Amoroso, as well as to Elaine B Trujillo for helpful reviews of the manuscript.

#### **References:**

1. Trujillo JR, Jaramillo-Rangel G, Ortega-Martinez M, Penalva de Oliveira AC, Vidal JE, Bryant J, Gallo RC: International NeuroAIDS: prospects of HIV-1 associated neurological complications. *Cell Res* 2005, 15(11-12):962-969.
2. Sacktor N: The epidemiology of human immunodeficiency virus-associated neurological disease in the era of highly active antiretroviral therapy. *J Neurovirol* 2002, 8 Suppl 2:115-121.

3. d'Arminio Monforte A, Cinque P, Mocroft A, Goebel FD, Antunes F, Kat-lama C, Justesen US, Vella S, Kirk O, Lundgren J: Changing incidence of central nervous system diseases in the EuroSIDA cohort. *Ann Neurol* 2004, 55(3):320-328.
4. Oliveira JF, Greco DB, Oliveira GC, Christo PP, Guimaraes MD, Oliveira RC: Neurological disease in HIV-infected patients in the era of highly active antiretroviral treatment: a Brazilian experience. *Rev Soc Bras Med Trop* 2006, 39(2):146-151.
5. Koranik IJ, Wuthrich C, Dang X, Rottnek M, Gurtman A, Simpson D, Morgello S: JC virus granule cell neuronopathy: A novel clinical syndrome distinct from progressive multifocal leukoencephalopathy. *Ann Neurol* 2005, 57(4):576-580.
6. Riedel DJ, Pardo CA, McArthur J, Nath A: Therapy Insight: CNS manifestations of HIV-associated immune reconstitution inflammatory syndrome. *Nat Clin Pract Neurol* 2006, 2(10):557-565.
7. Vendrely A, Bienvenu B, Gasnault J, Thiebault JB, Salmon D, Gray F: Fulminant inflammatory leukoencephalopathy associated with HAART-induced immune restoration in AIDS-related progressive multifocal leukoencephalopathy. *Acta Neuropathol (Berl)* 2005, 109(4):449-455.
8. Gray F, Chretien F, Vallat-Decouvelaere AV, Scaravilli F: The changing pattern of HIV neuropathology in the HAART era. *J Neuropathol Exp Neurol* 2003, 62(5):429-440.
9. Bratt G, Hammarin AL, Grandien M, Hedquist BG, Nennesmo I, Sundelin B, Seregard S: BK virus as the cause of meningoencephalitis, retinitis and nephritis in a patient with AIDS. *Aids* 1999, 13(9):1071-1075.
10. Vallbracht A, Lohler J, Gossmann J, Gluck T, Petersen D, Gerth HJ, Gencic M, Dorries K: Disseminated BK type polyomavirus infection in an AIDS patient associated with central nervous system disease. *Am J Pathol* 1993, 143(1):29-39.
11. Lesprit P, Chaline-Lehmann D, Authier FJ, Ponnelle T, Gray F, Levy Y: BK virus encephalitis in a patient with AIDS and lymphoma. *Aids* 2001, 15(9):1196-1199.
12. Hirsch HH, Steiger J: Polyomavirus BK. *Lancet Infect Dis* 2003, 3(10):611-623.
13. Arthur RR, Dagostin S, Shah KV: Detection of BK virus and JC virus in urine and brain tissue by the polymerase chain reaction. *J Clin Microbiol* 1989, 27(6):1174-1179.
14. Behzad-Behbahani A, Klapper PE, Valley PJ, Cleator GM: BK virus DNA in CSF of immunocompetent and immunocompromised patients. *Arch Dis Child* 2003, 88(2):174-175.
15. Behzad-Behbahani A, Klapper PE, Valley PJ, Cleator GM, Bonington A: BKV-DNA and JCV-DNA in CSF of patients with suspected meningitis or encephalitis. *Infection* 2003, 31(6):374-378.
16. Hirsch HH: BK virus: opportunity makes a pathogen. *Clin Infect Dis* 2005, 41(3):354-360.
17. Vago L, Cinque P, Sala E, Nebuloni M, Caldarelli R, Racca S, Ferrante P, Trabottoni G, Costanzi G: JCV-DNA and BKV-DNA in the CNS tissue and CSF of AIDS patients and normal subjects. Study of 41 cases and review of the literature. *J Acquir Immune Defic Syndr Hum Retrovirol* 1996, 12(2):139-146.
18. McArthur JC, Haughey N, Gartner S, Conant K, Pardo C, Nath A, Sacktor N: Human immunodeficiency virus-associated dementia: an evolving disease. *J Neurovirol* 2003, 9(2):205-221.
19. Cinque P, Bossolasco S, Brambilla AM, Boschini A, Mussini C, Pierotti C, Campi A, Casari S, Bertelli D, Mena M, Lazzarin A: The effect of highly active antiretroviral therapy-induced immune reconstitution on development and outcome of progressive multifocal leukoencephalopathy: study of 43 cases with review of the literature. *J Neurovirol* 2003, 9 Suppl 1:73-80.

*Materials of the Conferences***HORMONE-ADAPTIVE-METABOLIC  
MODEL OF CHRONIC NON-INFECTIOUS  
DISEASE FORMATION – NEW CONCEPT  
OF PREVENTIVE MEDICINE**

Grigorenko A.P., Khoshchenko Yu.A.  
*Belgorod State University  
Belgorod, Russia*

An original strategy of chronic non-infectious human diseases treatment and prophylaxis, in the basis of which the model of hormone-adaptive-metabolic imbalance lies, is offered.

With the body's stopping growing and developing the factors which provide them (somatotrophic hormone and others) don't disappear but keep on having effect with a specific constancy causing inhibitory effects of glucose and amino-acids transportation through cells' and vascular membranes. This leads to chronic energy failure which can be qualified as substrate hypoergosis. Hypoergosis is the basic factor which forms chronic non-infectious diseases (atherosclerosis, hypertensive disease, diabetes of the II type and others) by means of mechanisms of hormone-adaptive-metabolic misbalance. Possible nosotropic mechanisms of main human chronic non-infectious disease genesis and principles of their treatment and prevention are shown forth here detailed enough.

The epidemiologic situation fully formed over recent years in the Russian Federation which is connected with the growth of cardiovascular diseases and considerable increase of death rate because of them represents a direct health risk for the population and the losses inflicted result in significant economic disbenefit. The economic disbenefit conditioned by temporary or constant loss of earning capacity, untimely death because of hypertension complications, ischemic heart disease and cerebrovascular diseases, only in 1999 made about 29,3 billion roubles, and by 2005 it had increased by an order greater.

The world's experience points at present abilities of increasing human and material losses because of the specified diseases; one of them serving as primary and secondary prevention measures, which represent a promising area of health care. As the theoretic foundation of

preventive measures all over the globe now the concept of disease development risk factors stands out. The success of this concept application which is the framework of "the second antiepidemic revolution" (screening – examination with risk groups revelation) is definite. In many economically developed countries the morbidity and death rates because of cardiovascular diseases have decreased. However, the appearance of risk factors themselves inaugurates the developed pathologic process which so far has not taken the form of a specific nosologic disease. This complicates carrying out primary preventive measures of chronic somatic diseases. It should be also taken into account that the correction of high risk of chronic somatic disease development more often than not calls for the necessity of pharmacologic preparations use. First, it is unlikely to be efficient in the population level, and second, from the carried out research of such countries as Sweden and the USA it is seen that present-day therapeutic agents have no affects on chronic non-infectious disease death rate [1,2].

Thus, it appears to be of current interest to form a new conceptual avoidance and treatment policy that would allow preventing not only the risk of somatic pathology development, but also, in the conditions of the developed pathology, planning methods and principles of chronic non-infectious disease medical rehabilitation pathogenetically wisely.

By now certain scientific data in various fields of medical knowledge which are the precondition for creating a new strategy of prevention and treatment of chronic non-infectious diseases, that is: the ontogenetic medicine model of Dilman V.M. [4], the hypoergosis notion formulated by Yefuni S.N., Shpektor V.A. [5] and the stress theory of Selye G. [11], have been cumulated.

The basic thesis of the ontogenetic model is the statement about the fact that the main non-infectious human diseases are formed in ontogenesis under the effect of growth and development factors (somatotrophic hormone, placental lactogen and others) which don't disappear with their finishing, but affect with a specific constancy. By now it has been known

that a somatotrophic hormone (STH) possesses an acute insulinoid and chronic contrinsular effects [6]. That is why it is not difficult to suppose that even in a healthy organism under the effect of STH with the course of time inhibitory mechanisms of partial limitation of glucose uptake by the cells and tissues of an organism are formed, in other words – a diabetogenic state comes into being. The presence of diabetes of the II type in acromegaly patients confirms this fact. However, in 1981 Yefuni S.N. and Shpector V.A. offered to bring the term “hypoergosis” [5], having subdivided it into hypoxic, enzymatic and substratic ones, into the classification of hypoxias. In the opinion of the denoted authors, an energy failure of cells and tissues of the organism lies in the basis of hypoergosis. The substratic hypoergosis conditioned by the lack of substrate in the cell can realize the three main pathogenetic directions of human chronic non-infectious diseases:

1) Citric acid cycle, glycolysis, gluconeogenesis in all live systems, as a rule, are in the costate; the energy system of the cell being defined by the correlation of nucleotides – adenosinediphosphate – adenosinetriphosphate – adenosinemonophosphate (ADP-ATP-AMP) [7]. In case of ATR synthesis on any of the reasons (lack of substrate, oxygen or enzyme), and as a result, its decreasing in the cell, a disequilibrium of the cell's energy system towards ADP increase, that leads to the glycolysis key enzyme – phosphofructokinase, activation. This enables to keep up a sufficient cells' energy potential, but only on account of the glycolysis system. The provider of energy substrates for the glycolysis is a gluconeogenesis. A by-effect of the glycolysis is lactate accumulation – lactacidosis. From now forth, with decreasing of acetyl coenzyme A (CoA) derivative, in the Krebs cycle its accumulation takes place which leads to the synthesis of  $\beta$ -oxy- $\beta$ -methylglutaryl-coenzyme-A (OMG-CoA) from the three CoA molecules. The OMG-CoA is converted into mevalonic acid which is a cholesterol precursor. From the mode of the OMG-CoA formation the reaction can go either towards cholesterol synthesis or towards ketone bodies formation. Ketoacidosis appears, i.e.  $\beta$ -oxidation of aliphatic acids in the liver activates, and fatty energy way starts prevailing. Gluconeogenesis supposes albuminolysis as well. The immune system albumin, being the most mobile one, splits at that causing

immuneogenesis changes [4]. The inhibitory mechanisms of partial limitation of glucose uptake, which initiate the formation of substrate hypoergosis, stimulate hyperglycemia and hyperinsulinemia, that activates cholesterol, triglycerides and lipoproteides synthesis in the liver. The activation of  $\beta$ -oxidation of aliphatic acids and intensification of cholesterol synthesis out of mevalonic acid as well as the direct mobilizing effect of somatotrophic hormone on the lipolysis lead to lipid accumulation in the immune system cells, that results in the inhibition of cellular immunity and promotion of humoral one. The accumulation of lipids on thrombocytes leads to activation of thromboxane and exhaustion of prostacyclin [4];

2) Founding on the stress concept of Selye G. [11] a series of stereotyped adaptive reactions intended to provide the defence of the organism appears in vivo in response to any alterations requiring its working capability increase. The totality of these defence reactions got the name of “general adaptive syndrome”, or “stress” for short, and the factors causing it were denoted as “stressors”. The pathological processes appearing because of the stressors' action Selye G. denoted as adaptation diseases. Hypoxia is known to be one of the most powerful stressors. But as long as in the competence of Krebs cycle three interchangeable factors matter – adequate content of CoA, enzyme and O<sub>2</sub>, the decrease or absence of one of these factors lead to the ATP synthesis disorder, that activates the nonspecific stress and adaptation mechanisms through hypothalamus, pituitary and adrenal cortex. That is why the lack of metabolic substrates (substrate hypoergosis) or enzymes (enzyme hypoergosis) can be referred to stressors quite as much as hypoxia, with the only difference – the first two factors affect mostly in delayed mode, i.e. chronically or subacutely, and hypoxia, most commonly, - acutely.

Thus, proceeding from the statement that hypoergosis being a powerful endogenic stressor naturally promotes the nonspecific “adaptive” brain and body system and gives rise to adaptation diseases within the frame of the general adaptive syndrome formation. This scheme can be introduced as follows: a powerful endogenic stressor – substrate or enzyme hypoergosis promotes releasing of – hypothalamic hormones which, in their turn, activate pituitary hormones (ACTH, STH, TTH



and others), and the last, in their turn, provokes the discharge of stress hormones (cortisol and mineralocorticoids). Therefore, the hypoergosis patient's body lives in the state of constant chronic stress. In the course of time it results in appearing of a pathologic state resembling "cushingoid" – fatty degeneration of face and the upper part of the body, disorders of hydro-electrolytic metabolism, emergence of hydrops, peripheral vessels spasm and arterial tension rise, secondary kidney ischemia with rennin-angiotonin-aldosterone system agitation;

3) Following the concept of Yefuni S.N. [5] about hypoergosis as a state when not a decrease, but vice versa – an increase of  $O_2$  tension in the cell, i.e. hyperoxia, takes place, it is necessary to give consideration to this complex of hypoergosis pathogenesis mechanisms.

The cell hyperoxia provoking the processes of lipid peroxidation (LPO) appears as the result of a surplus content of  $O_2$  in the cell because of its abated utilization. The formation of  $O_2$  active forms, being more powerful oxidation agents than molecular oxygen, is one of the most important conditions for the LPO processes running [8,9,10]. The formation of  $O_2$  active forms is the consequence of an incomplete single-electron ( $O\cdot$ ), two-electron ( $H_2O_2$ ) or three-electron ( $\cdot OH$ ) electronation instead of the complete four-electron one resulting in water formation. The process of complete reduction of  $O_2$  to  $H_2O$  is more energy dependent than the processes of incomplete reduction; that is why it becomes clear that the formation of  $O_2$  active forms comes into being in particular with the deficit of energy substrates and finally – ATP. Hyperoxia not only initiates the processes of LPO, but also changes the DNA structure, damages collagen, hyaluronic acid, exhausts the antioxidant system, provokes the activation of arachidonic acid synthesis with the formation of prostaglandins, leukotrienes and interleukins [4,8,9,10].

These are the principle directions of pathogenetic mechanisms of main non-infectious diseases. However, with the formation of chronic diseases one can find both common features typical of this whole group of diseases, and specific features of pathogenesis characterizing a certain disease. For example, for atherosclerosis a typical and prevailing mechanism of pathogenesis is the cell hyperoxia with the formation of  $O_2$  active forms which initiate the

LPO processes on cells' membranes. It is the primary damage of the intima of arterial vessels and cells' membranes that underlies arteriosclerosis, and only then the process of atherosclerosis plaque deposits to the damaged vessels' intima associated with lipid metabolism disorder, nascence of immune lipid complexes conditioned by glycolysis and gluconeogenesis.

The pathogenesis of obese diabetes is more complicated. Chronic or subacute hypoergosis leads to hyperglycemia and hyperinsulinemia which, in the course of time, forms resistance to insulin receptors. This, early or late, results in the atrophy of  $\beta$ -cells of the pancreas. Being a powerful stressor, hypoergosis leads to activation of the adaptive system with the increased synthesis of contrinsular hormones which stimulate glycolysis and gluconeogenesis and, as the result, fatty energy way ( $\beta$ -oxidation of aliphatic acids) starts prevailing. Lactacidosis and ketoacidosis grow. Arteriosclerosis is in progress. The cell hyperoxia leads to micro- and macroangiopathies. Glycolysis and gluconeogenesis provoke immune disorders.

Arterial hypertension has more simple mechanisms of pathogenesis. Hypoergosis, being a powerful endogenic stressor, activates the adaptive system, leading to a chronic discharge of stress hormones which define the peripheral vascular effects, stimulate pressor albumin factors synthesis by a vascular wall (neuropeptide-Y, endothelins 1,2,3). Psycho-emotional factors (stressors) also have a definite significance.

In the basis of the ischemic heart disease appearing mechanisms also hypoergosis lies and it initiates the LPO products' and boosters' [8,9,10] membrane damaging action and is mediated by the following mechanisms:

1. By the LPO over activation conditioned by the cell hyperoxia when a considerable part of membrane phospholipids is subject to peroxidation degradation and lipid phase of the membrane becomes more rigid. It limits the conformation mobility of the polypeptide chain and, as the result, the capacity of enzymes, receptors and canal forming albumins built into the membranes, decreases. The formation of interlipid, interalbumin and lipid-albumin cross-links on account of cooperation with secondary LPO products and, in particular, with malonic dialdehyde, promotes it. Such course of events being attended, for example, by the inhibition of

sarcoplasmic reticulum Ca-ATPase activity leads to failure of  $\text{Ca}^{2+}$  removal from sarcoplasm and realization of damaging action of this cation excess over cardiac myocytes [8,9,10];

2. The  $\text{Ca}^{2+}$  intracellular concentration increase promotes the intensity of this cation penetration into the cell from the ectocytic medium. It is connected with the fact that during the LPO process in the water-repellent "tail" of an aliphatic acid there appears a hydrophil peroxy group. If complexes of such oxygenized phospholipids in every of the membrane's monolayers turn out to be located one opposite the other, then canals of hyperpermeability (clusters), which are permeated, in particular, for  $\text{Ca}^{2+}$ , are formed.

The overincrease of such clusters' amount can become the foundation of fragmentation and destruction of the sarcolemma membrane and sarcoplasmic reticulum;

3. The appearance of a hydrophil peroxy groups' membrane lipid bilayer in the water-repellent area kind of "loosens" this area and makes the present in it albumin components more penetrable for proteolytic enzymes. It promotes the destruction of bio-membranes as well;

4. The direct oxidation of sulfhydryl groups in active enzyme centres, enzymes as well, located in membranes leads to the activation of these enzymes and the membranes' permeability increase;

5. The destruction of the substances possessing antioxidant activity (vitamins, steroids, ubihinon).

A very important conclusion follows the above said: thanks to the unbalanced LPO activation induced by free oxygen radicals, the plasmalemma, as well as the membranes of intracellular organelles – chondriosomas, sarcoplasmic reticulum and lysosomas breakdown happens. It leads to the inhibition of oxidative phosphorylation and  $\text{Ca}^{2+}$  transportation, releasing lysosome autolytic enzymes, deep functional disturbance and, finally, necrocytosis.

Thus, on the basis of the offered model – hormone-adaptive-metabolic imbalance of the body, it seems to be possible to state its fundamentals, and also the concept of the avoidance policy and treatment of human chronic non-infectious diseases.

1. In the root of human chronic non-infectious diseases emergence a substrate

hypoergosis – a chronic energy deficiency of cells, systems and organs, lies.

2. The main etiologic factors initiating hypoergosis seem to be the factors of growth and development (STH, PL and others), in the result of chronic action of which inhibition mechanisms of partial glucose and amino acids transportation and utilization limitation.

3. STH, possessing chronic contrinsular action, performs conformation changes of cells' and vascular membranes, that leads to the breakdown of glucose and amino acids transportation and utilization, that, after all, results in the complex of compensatory- adaptive reactions of the body aimed at enhancement of its energetics.

4. A side product of compensatory-adaptive reactions of the body, aimed at its homeostasis restoration, i.e. a means of realization, is the body's homeostasis hormone-adaptive-metabolic imbalance leading to the accumulation of semi-oxygenated metabolic products.

5. As the result of the forming hormone-adaptive-metabolic imbalance of the body, the energy mode changes lawfully, stepping gradually from energetically beneficial aerobic oxidation of metabolic substrates to a less beneficial – anaerobic way of glucose oxidation, that leads to the accumulation of products of damaged metabolism and adaptation diseases formation.

6. The substrate hypoergosis is the main "basic" pathogenetic factor forming chronic energy deficiency in the body, and the manifestation of chronic non-infectious diseases, apparently, is realized both with the help of risk factors and with the help of various external "permitting" stress factors (smoking; alcohol overindulgence; adynamy; overconsumption of saturated fats, hydrocarbons, salt; psycho-emotional stress, chronic infection and others).

Methods and principles of treatment and prophylaxis of substrate hypoergosis are based on these statements; they including the following measures:

1. Appropriate motor regime, removing insulin resistance of cells' membrane receptor apparatus, which appeared against the background of adynamy and chronic action of STH.

2. Rational balanced diet with enough accessory food substances and antioxidants,

unsaturated fats, trace substances, dietary fiber, pectin, and other components.

3. Strict control of patients' weight, excluding risk factors.

4. Administration of individually tested medicaments from antioxidant and antihypoxant groups on the method of Foll R. in case of a pathological process manifestation.

5. Regulatory and traditional therapy (multiresonance and bioresonance therapy, homeopathy, reflex therapy, manual therapy, triptis, phytotherapy, leech therapy, apitherapy, exercise therapy, respiratory gymnastics and other kinds of medical rehabilitation).

6. If necessary, a palliative care (disaggregants, vascular, neuroprotective, neurotrophic antihypertensive drugs and others).

The offered measures of prophylactic and rehabilitation actions should be carried out on the patients permanently, without intermission, because the main pathogenetic factor "substrate hypoergosis" functions in the human body chronically on constant conditions.

Thus, the offered concept can be a theoretic foundation for the realization of priority national projects in the field of human chronic non-infectious diseases prophylaxis and treatment. It will allow putting the principles of prophylactic and remedial treatment of atherosclerosis, hypertension disease, ischemic heart and brain disease, diabetes of the II type, metabolic immunosuppression, etc. into practice pathogenetically intelligently and highly effectively.

#### References:

1. Apanasenko G.L., Popova L.A. Medical Valeology. – Rostov-on Don "Phoenix"; Kiev "Zdorovy", 2000 - p.243.

2. Apanasenko G.L. Thermodynamical Concept of Chronic Noninfectious Diseases Treatment //Therapeutic records - 1990- V.62.- N12 - p. 56-59.

3. Apanasenko G.L. Evolution of Bioenergy and Human Health – Saint-Petersburg: MGP "Petropolis", 1992 - p.122.

4. Dilman V.M. Four Models of Medicine – L.: Medicine, 1987 – p.286.

5. Yefuni S.N., Shpector V.A. Hypoxic States and Their Classification // Anaesthesia and Reanimation - 1981-N2 - pp.3-12.

6. Keda Yu.M. Influence of Somatropin on Carbohydrate Metabolism and Interaction of

Somatropin and Insulin // Problems of Endocrinology - 1985.-N6.-V.31.-pp.75-80.

7. Lehninger A. Biochemistry: Translation from English – M.: Mir, 1976.- p.956.

8. Medvedev Yu.V., Tolstoy A.D. Hypoxia and Free Radicals in Development of Pathologic States of an Organism – M.: LLC "Terra Calendar & Promotion", 2000 – p. 232.

9. Petrovsky B.V., Yefuni S.N., Demurov Ye.A., Rodionov V.V. Hyperbaric Oxygenation and Cardiovascular System – M.: Nauka, 1987 – p. 325.

10. Ryabov G.A. Pasechnik I.N., Azizov Yu.M. Active Forms of O<sub>2</sub> and Their Role in Some Pathologic States // Anaesthesia and Reanimation - 1991.-N3.-p.63-69.

11. Selye G. Stress without Distress: Translation from English – M.: Progress, 1982 – p.123.

---

The article is admitted to the International Scientific Conference "Fundamental problems of medicine and biology", India, Goa, March, 1-11st, 2007, came to the editorial office on 27.02.07

#### EVALUATION OF THROMBOCYTE CAPACITY AS METHOD OF EARLY DIAGNOSTICS OF HEMORRHAGIC SYNDROME AT CRIMEAN-CONGO HEMORRHAGIC FEVER

Lazareva Ye.N., Samotrueva M.A.  
Asrakh State Medical Academy  
Astrakhan, Russia

Nowadays in the Southern regions of Russia, as well as in Astrakhan Region, a steady incidence rate of Crimean-Congo hemorrhagic fever (CCHF) is marked (Maleyev V.V., Sannikova I.V., 2005); up to 9% of fatal cases of the disease being registered (Maleyev V.V., 2003), the root of which is in deep hemocoagulation disorders. According to the modern data, the initiating role in the pathogenesis of hemorrhagic syndrome and thrombotic complications at many infectious processes is played by thrombocytes (Polyakova A.M., 2000).

With the purpose of carrying out a modern and appropriate pharmacological correction of hemostasis disorders at CCHF there appeared a

necessity to define the capacity of blood platelets during the acute period of the disease. To solve the specified problem clinical-laboratory trial of 20 patients was carried out on the basis of Astrakhan State Medical Academy and Regional Clinical Infectious Hospital, Astrakhan, from May till August, 2005. The patients' average age was  $56,6 \pm 4,16$  years old. The disease proceeded in the form of average severity (62%) and severe (38%) forms. The diagnosis was made on the foundation of a complex of anamnestic, epidemiological, clinical-laboratory data and was serologically verified in the IFA reaction to the CCHF virus antigen with the antibody titer of 1:800 – 1:1600. Counting of platelets in the venous blood and the analysis of their aggregative ability were carried out on the analyzer NFP BIOLA (model 230LA). The platelet capacity was evaluated in aggregation value (V %) and speed (S %). ADP in the concentration of 2,5  $\mu\text{Mol}$  was chosen as an inductor.

In 70% of the patients clinical implications of hemorrhagic syndrome in the form of intensive hemorrhagic rash on skin integuments and gingival bleeding were marked. In peripheral blood platelet number decreased up to  $71,2 \pm 5,9 \times 10^9/l$ , and in venous one – up to  $48,5 \pm 4,6 \times 10^9/l$ ; it being  $17,7 \times 10^9/l$  in single cases.

The research results showed that the aggregation value (V%) was strongly decreased as compared to the control values ( $4,02 \pm 0,7$  и  $24,3 \pm 1,4$  при  $p < 0,0001$ ), and the time (Tv) during which platelet activity reached its maximum reduced to  $1'25'' \pm 0,6$  from the regular one of  $4'01'' \pm 0,5$ . The aggregation speed (S) was authentically decreased twofold from the control values ( $7,2 \pm 0,5$  and  $4,3 \pm 1,3$  accordingly,  $p < 0,0001$ ), and the time (Ts) of reaching its maximum - decreased ( $20'' \pm 1,8$  against  $12'' \pm 0,4$ ,  $p < 0,05$ ). The aggregates were of small radius ( $3,5 \pm 0,23$ ), while in donors it was equal to  $6,5 \pm 0,7$ . The discharge reaction of own agonists in the platelet granules was not registered on all the occasions, that gave evidence of the release failure or their absence.

Thus, considerable disorders of hemostasis thrombocyte link in CCHF patients were found out in the result of the research. Perhaps, it is a leading cause of the hemorrhagic syndrome development. That is why, when admitting patients to the hospital, it is necessary to define

the platelet capacity for carrying out the appropriate pathogenetic therapy.

---

The article is admitted to the III International congress "Practising doctor", Russia (Sochi), April, 10-12th, 2007, came to the editorial office on 03.03.07

**METABOLIC AND CIRCULATORY  
DYNAMICS DISORDERS IN TEENAGE  
GIRLS WITH OLIGOMENORRHEA AND  
SECONDARY AMENORRHEA**

Levenets S.O., Nachetova T.A.

Vvedenskaya T.S.

*Institute of Child and Teenager Welfare AMS  
of the Ukraine  
Kharkov, Ukraine*

Disorders of menstrual function like oligomenorrhea (OM) and secondary amenorrhea (SA) in teenage girls in most cases are attended by disorders of the cardiovascular system and lipid metabolism functional state. The lipid profile study showed the existence of dyslipidemia of atherogenic character in the majority of patients with the specified pathology. Central circulatory dynamics disorders took place in more than 80% of the cases, only in 6% of the patients the showings characterizing uterus and ovary blood supply fell within the limits of the norm.

Purpose of the work: finding heart, uterus and ovaries vessels Doppler investigation complex of showings for an individual circulatory dynamics state evaluation. For the realization of the purpose Doppler investigation of the heart and vessels of uterus and ovaries in 92 patients with OM and SA was carried out. The estimation of diagnostic value of the obtained showings was carried out according to the system-information analysis of Vald.

The main diagnostic markers of a circulatory dynamics system disorder were: myocardial thickness less than 5mm (yes – RQ = +6; no – RQ = -0,4), fraction of cardiac output less than 63% (yes – RQ = +6,5 ; no – RQ = -2,9), systole blood velocity of the left atrium more than 80cm/sec (yes – RQ = +6; no – RQ = -0,4), relaxation time of the left ventricle more than 0,06 sec (yes – RQ = +5,6; no – RQ = -3),

systole blood velocity (SBV) in the uterine artery less than 30 cm/sec (yes – RQ = +6; no – RQ = -1,5), SBV in the right ovarian artery less than 30 cm/sec (yes – RQ = +8; no – RQ = -2,8), SBV in the left ovarian artery less than 30 cm/sec (yes – RQ = +7; no – RQ = -4,3), difference between SBV in the uterine and the right ovarian arteries more than 10 cm/sec (yes – RQ = +9,4; no – RQ = -1,8), difference between SBV in the uterine and the left ovarian arteries more than 10 cm/sec (yes – RQ = +10,4; no – RQ = -2,3), difference between SBV in the right and left ovarian arteries more than 10 cm/sec, (yes – RQ = +6,7; no – RQ = -0,8).

The sum (-13) testifies to the absence of circulatory dynamics disorders, from (-13) to (+13) – to the initial manifestations of the disorders, the sum of more than 13 testifies the existence of evident disorders which require medicamental correction and physiotherapy. The correction of the specified circulatory dynamics disorders in the teen age in patients with OM and SA will allow preventing serious functional disorders of the cardiovascular system.

---

The article is admitted to the III International congress "Practising doctor", April, 10-12th, 2007, Russia (Sochi), came to the editorial office on 16.03.07

**PSYCHOPHYSIOLOGICAL STATE OF  
NAVAL SPECIALISTS IN THE PERIOD OF  
ACUTE ADAPTATION TO SERVICE  
UNDER CONTRACT**

Mosyagin I.G.

*North State Medical Universit*

*SRU of Naval Medicine*

*Arkhangelsk, Russia*

The present-day Navy change-over to preferential recruiting specialists doing military service under the contract sets the problem of various ranks navy soldiers' adaptation process in-depth study. While analyzing the research results of the naval specialists' psychophysiological state the ranking on the ground of their military status was used. Depending on the type of business before entering into the contract there were the following groups distinguished: 1) specialists who were called-up to serve in the

Navy 12 months ago (n=170); 2) persons who had their first contract closed (n=90); 3) military retirees (n=100). The research was carried out within 2 years after entering into the contract in 4 stages: primary – at making the contract, and then in 6, 12 and 24 months of the service.

It has been established that the most difficult period of psychological adaptation to military service under contract for the first group persons was the interval between 6 and 12 months of service, which is characterized by considerable lowering of emotional stability levels (by 46,4%), moral dynamism (31,1%), assertion (34,8%). The second year of service of the first group persons was attended with positive personal traits changes: growth of emotional stability levels (by 42,3%), moral dynamism (by 33,3%), assertion (twofold) and was the of psychological adaptation acute phase completion.

The efficiency, stability and reaction rate index dynamics was characterized by the following: compared to the primary research, in 6 months of service the levels of the specified showings of the first group military servants decreased, in 12 months of service the evidence of the specified features decrease was maximal, in 24 months of service the efficiency, stability and reaction rate levels increased considerably. The process of adaptation to service under contract for the first two years was attended with authentic ( $p<0,05$ ) lowering of adaptive capacities, neuropsychic resistance, communication potential, professional suitability and with moral norm decrease tendency by the end of the first year of service. In the consequence of the comparative analysis of electroencephalogram (EEG) average value showings, compared to the results of the primary survey, in occipital derivations authentic ( $p<0,05$ )  $\alpha$ -rhythm frequency (within normal diapason), oscillation amplitude, with preservation of reactions to overventilation, closing and opening eyes, and index reduction, that should be evaluated as brain adaptation process inhibition and lassitude development, have been established in 12 months of service. In two years of service the  $\alpha$ -rhythm amplitude and frequency in the occipital derivations grew and reached the index level at primary survey.

In the survey consequence by the second year of service the maximal alteration of the majority of the showings characterizing

psychophysiological state has been established in the persons of the second group. The process of adaptation to service under contract in the second group military seamen within the first two years was attended with authentic ( $p < 0,05$ ) lowering of neuropsychic resistance by the end of the second year of service. No authentic difference between the stages on the levels of adaptive capacities, communication potential, professional suitability and moral norms were established. As a result of the comparative analysis of average EEG showings in 2 years of service, compared to the results of the primary survey, in the occipital derivations authentic ( $p < 0,05$ )  $\alpha$ -rhythm index, frequency and amplitude decrease was registered. No significant differences in amplitude and frequency EEG characteristics in the interim stages of the investigation were established.

The first two years of service among the military seamen of the second group were characterized by authentic ( $p < 0,05$ ) growth of moral dynamism (by 27,0%), self-sentiment (more than twofold), recollection, vigour and energy (на 26,4%), compliance and latitude to people (more than twofold). The level of emotional stability increased authentically ( $p < 0,05$ ) in 12 months of service, but then decreased considerably. As the result of formally dynamic personal properties evaluation the essential decrease of psychomotor (by 13,4%), intellectual (by 11,1%), communicative (by 7,2%), general energy (by 10,6%), and also the decrease of general emotionality (by 10,0%) and general adaptiveness (by 11,1%) in 24 months of service have been established in the second group persons.

In the result of the survey the maximal alteration of most of the showings characterizing psychophysiological state has been established in the third group persons in 6 months with the tendency of stabilization, compared to the prior data, by the end of the second year of service. Thus, the stability of nervous processes balance has decreased by 24,8% in 6 months of service, compared to the primary survey. Then the specified showing increased authentically ( $p < 0,05$ ) by 21,8% (3 stage), and then – 9,8% more.

In the result of the comparative analysis of average EEG value showings, compared to the primary survey results, in the occipital derivations authentic ( $p < 0,05$ )  $\alpha$ -rhythm index decrease has been registered in 6 months of service. In two years of service  $\alpha$ -rhythm amplitude and frequency indexes in the occipital derivations grew and reached the level of the primary investigation values. No authentic differences between amplitude and frequency EEG characteristics between the 1 and 3, 2 and 3, 3 and 4 stages of the investigation has been established.

As the result of formally dynamic personal properties evaluation the essential decrease of psychomotor (by 6,3%), intellectual (by 11,1%), communicative (by 12,7%), general energy (by 12,0%), and also the decrease of general emotionality (by 12,3%) and general adaptiveness (by 15%) levels have been established in the contract service adaptation dynamics in the third group persons in 6 months of service.

Thus, the period of acute adaptation to service under contract in naval specialists passes within the space of two years and is attended by an essential ( $p < 0,05$ )  $\alpha$ -rhythm amplitude, frequency and index lowering in occipital derivations of brain, adaptive capabilities decrease and lassitude state development: in 6 months – in retirees who entered into the contract again; in 12 months – in military seamen who entered into the contract after one year call-up liability. For naval specialists, who prolong the contract, the adaptive capabilities level decrease within 24 months of service under the second contract is typical.

---

The article is admitted to the II conference «Basic researches in biology and medicine», Montenegro, June, 8-15th 2007r., came to the editorial office on 17.03.07

**SEASONAL ACTIVITY CHANGES OF  
CARBOHYDRATE-ENERGY AND  
PROTEIN METABOLISM TISSUE  
ENZYMES IN BLOOD OF NON-ADULTS  
LIVING IN CONDITIONS OF A PLAIN**

Nikitina V.V., Abdulnatipov A.I.

Sharapkikova P.A.

*Dagestan State Medical Academy  
Makhachkala, Russia*

The ability of enzyme systems to adaptation underlies the adaptive reactions of a body to various factors' actions, natural climatic one among them; that is why, on the ground of the data for this occurrence, one can characterize the adaptive abilities and homeostatic forces of a body in different age on the level of enzyme systems.

In this respect we have investigated the activity indexes of some enzymes of carbohydrate-energy and protein metabolism in blood of children and teenagers. The objects of the research were children and teenagers living in the city of Makhachkala. To carry out the research in the age aspect 70 learners of 9, 11, 13, 14 and 17 years old were selected.

When compared in autumn and spring the activity of both general and isozyme lactate dehydrogenase in the blood of non-adults, living in the conditions of a plain, a specific law in changing of these figures is observed. This law is reflected in the fact that the activity of general lactate dehydrogenase in autumn period is notably higher in the investigated age periods. The activity of isozymes in non-adults' blood changes similarly to total activity of lactate dehydrogenase. The results of the research on defining glucose-6-phosphate dehydrogenase in blood serum of non-adults, living in conditions of a plain, in autumn and spring showed the highest level of the enzyme activity at the age of 9: in autumn -  $400 \pm 7,3$  mE/l, and in spring -  $390 \pm 3,53$ mE/l. In the following age periods the enzyme activity changes ambiguously. At the age of 11 a considerable glucose-6-phosphate dehydrogenase activity decrease is registered; in spring this enzyme activity decreasing much more than in autumn and makes in autumn -  $260 \pm 8,1$ mE/l, and in spring -  $191 \pm 2,7$ mE/l. In teenagers of 13 and 14 in autumn the glucose-6-phosphate dehydrogenase activity increases considerably compared to the previous age group. In teenagers of 13 the activity of glucose-6-

phosphate dehydrogenase increases in spring, and at the age of 14 somehow ( $p < 0,05$ ) decreases compared to the previous age group. At the age of 17 the activity of this enzyme decreases again ( $p < 0,05$ ) compared to the previous age group and makes in autumn  $360 \pm 4,7$ mE/l, and in spring -  $290 \pm 3,1$ mE/l. The activity of alaninaminotransferase in the blood of non-adults, living in conditions of a plain, in autumn and spring during the investigated age periods suffers specific changes which lie in the fact that at the age of 9 the enzyme activity is low: in autumn -  $7,1 \pm 0,6$  mE/l, and in spring -  $6,7 \pm 0,7$  mE/l. In the following age periods (11, 13 and 14 years old) both in autumn and spring the enzyme activity decreases practically evenly. At the age of 17 the alaninaminotransferase activity decreases inconsiderably compared to the previous age group and makes in autumn  $16,5 \pm 0,9$ mE/l, and in spring -  $16,0 \pm 1,7$ mE/l. The aspartataminotransferase activity research results show that the activity of this enzyme decreases essentially both in autumn and in spring by the age of 14. In autumn in teenagers of 14 this enzyme activity makes  $21,5 \pm 1,3$  mE/l instead of  $12,5 \pm 1,3$  mE/l in 9-year-old children. In spring the aspartataminotransferase activity in teenagers of 14 makes  $20,9 \pm 2,9$  mE/l instead of  $11,9 \pm 1,1$  mE/l in 9-year-old children. At the age of 17 the enzyme activity in the blood of teenagers decreases insignificantly ( $p > 0,05$ ) compared to 14-year-old teens and makes in autumn  $20,1 \pm 1,1$ mE/l, and in spring -  $19,5 \pm 1,5$ mE/l. The results of the research on defining alpha-amylase activity in different age periods show that the activity of this enzyme in the blood of non-adults, living in conditions of a plain, both in autumn and in spring suffers no essential changes. Thus, in autumn the activity of alpha-amylase in children of 9 years old made  $3,51 \pm 0,41$  mE/l, and at the age of 17 -  $2,75 \pm 0,35$ mE/l. In spring the alpha-amylase activity in children at the age of 9 made  $2,9 \pm 0,4$  mE/l, and at the age of 17 -  $2,08 \pm 0,9$ mE/l.

---

The article is admitted to the International Scientific Conference "Homeostasis and infectious process", Moscow, May, 14-16th 2007г, came to the editorial office on 19.03.07

### ADVANTAGES AND DISADVANTAGES OF ENERGY PLENTIFUL SUPPLY IN ANIMALS' ORGANISM

Testov B.V.  
Perm State University  
Perm, Russia

In cells of an animal's organism the process of metabolic glucose oxidation is constantly going on and ATF molecules, which provide all biochemical reactions in the cell with energy, are being synthesized. The process providing the most effective energy generation is respiration. The respiration intensity is determined by the amount of oxygen and glucose which are delivered to cells by blood. At intensive loadings on the body animals intensify their breathing, but within relatively little limits. There is an opportunity to increase energy production by the cell on account of glycolysis (anaerobic lysis of glucose) intensification, which is carried out in cytoplasm of the cell and depends only on glucose availability. At large energy consumptions the body uses this method for the process of energy intensification, but it is of very little effect. At glycolysis a considerably less amount of ATF molecules appear. The energy intensification on account of glycolysis leads to sharp fall of glucose supply and biological accumulation of lactic acid.

Meanwhile, the success of the struggle for existence among dapper animals is governed in many ways by their speed. As distinct from plants, which are firmly pegged to one and the same place, animals use shelters, which often are located far from the source of food, for their being safe. Besides, individual selection, when the struggle for a sparring partner takes place, is very popular among animals. And intraspecific and interspecific competition for the niche of habitation demands from animals a great deal of energy expense in the short run. That is why an energy storage formation method appeared in higher animals. The accumulated energy fund allows for a comparatively short period of time consuming the energy, which manifold exceeds the energy created during the same period in the animal. For quick consuming the energy fund it should be stored in the form of made-up ATF molecules. Understanding this problem, scientists had been trying for long to find in the body a depot of ATF molecules, from where these molecules could be delivered to working cells by

the blood flow. However, no ATF molecules were detected in the blood.

We paid attention to gap junctions between cells which were demonstrated in 1958. The gap junctions represent an interspace between cells about 3mcm wide, which take part in intercellular communication. The research showed that through the interspace made inorganic ions and other small molecules can pass from one cell into the cytoplasm of another one, promoting electric and metabolic coupling. The passage occurs by means of membrane connexons of neighbor cells, which form a continuous water canal of a comparatively small diameter at closed butt joint. For long the necessity of such junctions for germinal cells remained unclear, though the junctions were observed in early stages of embryogenesis already. The destination of gap junctions can be explained if taking into account that through the connexons cells can exchange ATF molecules which have a small enough size. At shortage of self-energy the crying out for energy cells can get the ATF molecules from other cells which are performing energy transporting functions. The cells providing the energy transportation must be multiple, have a small diameter and possess the chondriosome system which is able to synthesize ATF. To perform such a mission small lymphocytes are the most appropriate as they are able to penetrate practically into all points of the multicellular organism. A small lymphocyte is a round cell with the diameter of 5-8 mcm and high nuclear cytoplasmic ratio. There is a very little amount of chondriosomes and ribosomes in the cytoplasm. The sizes of a small lymphocyte provide a great penetrative capacity. It allows the lymphocyte to penetrate into all systems of the body promoting energy demands of actively self-duplicating cells.

So, we think that energy storage is formed as accumulation of lymphocytes which, as required, get to the most desperately crying out for complementary energy cells and give them the made-up ATF molecules through the gap junctions. The complementary energy gets to the cells through the lymphatic system. For the storage formation a recurrent increase of the number of lymphocytes able to produce ATF molecules is necessary.

Such an increase seems to occur during the rest time (sleep) which any animal needs so much. For long we considered that sleep is needed by a human to let brain cells have a rest.



However, the need of sleep can be explained also by energy recharge of the body. In the night's repose period the body decreases muscles and brain blood supply and intensifies blood flow through the lymphatic system promoting the lymphocytes duplication process intensification. Preferentially it occurs during the night's repose. But often the human falls asleep in the day time also, especially after heavy physical activity and rich meal. It is connected with energy redistribution in the body. Thus, the body controls energy flows providing the most needy organs and tissues in the specified period of time. The night's repose is the most appropriate period for the promotion of total energy reserve used during the oncoming working day. The more lasting sleep is common for children and young people who possess a great energy reserve. It is not occasionally that getting old the human starts lying wakeful at night that testifies to a little energy reserve and the body's ruin risk increase.

**A great energy reserve is the cause of high radiation sensitivity.**

It is known that mammals and birds are the most sensible to ionizing radiation. All poikilothermic animals are more radiation-proof several times as much. It is connected with a large reserve of energy in homoeothermic animals which provides them a year-round activity under any conditions. The calculations suggest that when exposed to the lethal dose of irradiation, mammals die from the energy which promotes heating up of the body by 0,002 °C as a whole. At the same time, when exposed to radiation, the body's temperature increase of all mammals by 1-5°C is registered. Such heat production increase can be provided only on account of energy reserve of the body itself. Death of animals happens for the reason that the energy reserve, which the body must consume for the day-time, turns into heat proportionally to the irradiation dose when exposed to irradiation. At small radiation doses a little temperature increase occurs that is not dangerous and even useful sometimes. At large radiation doses the temperature rise leads to heat shock and necrocytosis. For this reason hyperthermia of the body during the radiation leads to radiation damage intensification, and hypothermia at the time of radiation creates the protective effect. High sensitivity of self-duplicating cells is conditioned by the fact that all dividing cells possess high energy. The hydrolysis of a

multitude of ATF molecules leads to a considerable temperature rise that causes necrocytosis. And a delay of the dividing after radiation can be explained by inactivation of the chondriosome multitude and deficiency of ATF molecules which are necessary for mitosis.

**Energy reserve in vivo is the cause of frequent virus infections.**

The inflow of microbes into the animal body usually is considered as an aggression. And though the body tries hard to get rid of the "unwelcome visitor", the microbes have adapted for the introduction and propagation in the cells of higher organisms. What attracts a virus to the introduction into the cells of a higher organism? The variant of using the higher organism genome replication for the virus genome replication seems to be probable. The matter is that to double the genetic information before its self-duplication the cell has to synthesize an enormous amount of complex organic compounds. It needs a lot of metabolic costs. The genetic material replication occurs only at mitosis. It is determined by the higher organism demands, and the organism regulates the dividing process in accordance with the development program. The most intensive mitosis occurs in the young organism (children). When introduced into a child's organism there are more chances for viruses to get into a self-duplicating cell, i.e. there are more chances for them to multiply successfully. That is why children may be more susceptible to diseases compared to an adult organism.

When the dividing process happens in most cells of an organ, active blood supply of this organ occurs, which is attended with an increased heat production and temperature rise. However, with no active cells' dividing its blood supply is essentially lower. When getting into an adult organism, very often it appears to get into a cell which isn't dividing. Then the virus replication success will be determined by its ability to make the cell duplicate. To do it it is necessary to initiate the genome replication process and get complementary energy resources. To get the complementary energy on account of the cell's metabolism intensification isn't possible as it is not possible to intensify the blood flow in a separate cell. And to intensify the blood flow in the whole body is not possible for the virus. However, there is a real opportunity to obtain the complementary energy from lymphocyte reserve on account of the gap effect. To obtain the

complementary energy by means of the gap junction the cell must give a certain signal to the lymphocytes located in the nearest lymph gland. After receiving the signal lymphocytes, which must provide with their ATF molecules the oncoming dividing process of the infected cell, will make way to the infected cell. Nowadays no mode of signal transmission to lymphocytes is known. We suppose that these signals appear as the result of electronic reorganizations of excited atoms. The signals can appear at imbedding of a virus into the genome of a dormant cell. Electronic reorganizations are attended by bioluminescence which usually attends mitosis. Since the infected cell needs energy sources unconnected with metabolism intensification, the energy reserve created by the body in the form of a great amount of migrating lymphocytes is a "cutie pie" for the infection. Using ready for the replication structure of the infected cell and the energy of lymphocytes delivering ATF molecules through the gap junction viruses can easily and quickly boost their population very much.

The most radical method of the body defence is, in this case, decreasing energy reserve that will make difficult for the viruses to get energy for propagation. Our research showed that when exposed to ionizing radiation a considerable part of the body's energy reserve converts into heat. Thus, the ionizing radiation ray treatment can be used for the therapy of the organism having fallen ill with virus infection.

#### **Ray treatment of laboratory mice with malignant tumors.**

For checking purposes of energy reserve decrease influence on virus infection we selected laboratory mice females with spontaneous tumors of milk glands. The tumors in the animals were in different development stages. The earlier carried out observations had testified that such animals, as a rule, die. We decided to see how a single total radiation of an animal influences the tumor epigenetics. There were formed two animal groups, one of which was used as the control one, and the other one got a single total radiation in the dosage of 3Gy. The ray treatment of the mice was carried out using the source  $^{137}\text{Cs}$ .

To study the tumor epigenetics sensory observation, length and radius measuring of the oncoma were carried out. The sensory observations testified that after the irradiation a clearer tumor boundaries determination takes place. After the exposure usually losing weight

by the animal and tumor recession were observed. At small-size tumor it stabilized and acquired cyanotic color but didn't resolve. If the tumor had sufficiently large sizes and evidently disturbed the animal, its being scratched and gnawed out were observed, that sometimes finished with the animal's death. The results of the tumor epigenesis in the radiation-exposed control mice testified that the tumor grows with different rate. In the control animals the tumor grew much faster (from 4 up to 10% a day). The average tumor increment in the radiation-exposed animals was within limits of 1-2%. The lifetime increase of the radiation-exposed animals was also marked. In the control animals metastases occurred; their being no in the irradiated mice. The data got testify that comparatively small dosages of total radiation essentially reduce the rate of spontaneous tumors' development in mice.

#### **The results of laboratory mice ray treatment after introduction of staphylococcus infection.**

It is known that bacteria have their own mitochondrial apparatus providing energy demands of a developing cell. However, when getting into an organism they can use the energy reserve of the animal, that will lead to their more successful propagation in the organism. To verify out supposition we carried out an experiment with radiation exposure of mice infected with *Staphylococcus aureus*.

To carry out the experiment there were formed 3 experimental and control groups of mice who one-day cultivation of aurococcus was introduced in different ways. The experimental groups were exposed to total radiation in the dosage of 3Gy from the source  $^{137}\text{Cs}$ . The introduction of the staphylococcus was carried out in three ways:

1. introduction of a drop with the cell culture into a section the back;
2. introduction of a lawny strip with deposited cells of the staphylococcus into a section on the back;
3. subcutaneous introduction of 0, 05 ml of staphylococcus culture using a syringe.

The quantity of the introduced cells in all the cases differed insignificantly. Using three modes of administration was aimed at the detection of the most effective reaction registration of an organism on the introduction of staphylococcus culture.

Watching the animals' state according the wound repair rate on the place of the section didn't detect a significant difference between the animals. More authentic differences the registration of the radiation exposed and control animals showed. After the exposure which was carried out in 1-2 days after the infection introduction we observed a greater losing weight of the radiation-exposed animals compared to the control ones. But on the 8th day already the weight gain of the radiation-exposed animals exceeded the weight gain of the control animals. On the 12th day the difference between the weight gain became authentic. Thus, we have made sure that the radiation-exposed animals recover from infectious diseases much quicker.

### Conclusion

The carried out research testified that a single total irradiation can condition sick animals' state. The irradiation for oncology disease treatment is very often applied. Traditional methods of oncology disease treatment with the help of radiation therapy are focused on tumor cells inactivation (damage). The radiation is performed with a strictly directed narrow-beam-radiation which must affect only the radiation-exposed cells. At that a great radiation dose, which is able to kill cancer cells, is used. We offer applying total (wide-field) radiation, which covers not only cancer but also stromal cells. The doses used at that can not kill or somehow essentially damage most of the cells. The amount of the applied dose must reduce the energy economy of the cell. When goal making it is our understanding that usually observed the irradiated in front of stromal cells tumor size reduction is explained not only by some tumor cells death but also by dividing intensity decrease. The tumor cells dividing intensity in many ways is conditioned by the energy which the body additionally deliver to both self-duplicating germinal and tumor cells. After the total radiation all the cells of the body incur an energy deficit, that is why the dividing cells suffer particularly. Thus, real opportunities are created for using small dose of irradiation to decrease the intensity of malignant tumor development. At that there is no need to expose to radiation the tumor place locally. It is important to irradiate the whole body or its significant part to escalate the rivalry of the cells for the stored energy reserved in the body. Under the circumstances the tumor cells will get

considerably less energy that will essentially slow the tumor growth. This method of preventive radiation of the body must be especially effective for virus infection.

At passed into the body bacterial cells self-duplicating the energy dependence is not so evident. That is why when introduced into the body the staphylococcus bacteria can multiply without using the body's energy. However, the carried out experiment testified that the body energy reduction at radiation takes toll on the bacterial cells (staphylococcus infection). Therefore, total radiation in small doses can be applied for therapy of infection processes which are caused both by viruses and bacteria.

---

The article is admitted to the International Scientific Conference "Scientific researches of the higher school in priority directions of a science and technics", Russia-Danija-Shvetsija-Finlandija-Norvegija-Estonija, July, 11-25th 2007г., came to the editorial office on 21.04.07

### MODERN METHODS OF PSYCHOPHYSIOLOGICAL CORRECTION

Urazayeva F.Kh., Urazayev Kh.F.

Dashkina A.A., Khamzina A.F.

*Sterlitamak State Pedagogical Academy  
Sterlitamak, Russia*

There is a range of methodical approaches of human functional state diagnostics, according to which one can firmly and objectively judge on the body's state and its changes [1, 2]. The research of Frolov M.V. [7] testifies that the emergency of emotional tension in a stress situation is attended by negative dynamics of spatial-temporal parameters of an electroencephalogram, and at the anxiety decrease the synchrony of alpha activity in anterior-posterior departments of the right hemisphere increases.

It was proved [6] that unlike symmetrical picture of intracortical connections normally, at the decrease of energetics and human frame of mind the agitation of the right frontal region of the cortex and relative decrease of functioning of the left one are registered. At depressive positions the spectral capacity of practically all rhythms authentically decreases, excluding theta-

and delta-rhythms, intensification of which occurs at the emotional tension [4, 5]. According to modern typology it is customary to distinguish two pathology types of emotional disorders: the first – with the overweight of active symptoms - enhanced emotional tension, impatience and anxiety; the second – with negative ones – emotional burnout, bad depressive position, social isolation and retardation [3]. Such differences are found out in the spectral capacity of beta- and alpha-rhythms, interconnections in alpha-diapason in endogenic and reactive depression patients [8, 9]. So, on the ground of the above said, an opportunity to select sound rhythm frequency, taking into account the peculiarities of spatial-frequency EEG characteristics, appears.

We have developed the rehabilitation methodology which allows solving this problem. The first and the second types of EEG disorders is set in if the average capacity of alpha- or beta-rhythms in the frontal derivations of the human right hemisphere is lower than in the neighbor derivations of the left one (the difference is more than 40-50%). The second type is manifested additionally, if the average capacity of alpha- or beta-rhythms in the left occipital derivations is lower than in the right ones (the difference is more than 40-50%). Also the availability of theta- or delta-diapason activity becomes apparent, with the amplitude of more than 50-60 mcV.

For brain rhythmic activity formation in the necessary direction it is offered to intensify the capacity of alpha- and beta-rhythms in the right frontal derivations with the help of binaural rhythms of the sinusoidal form with the frequencies correspondent to the calculated average frequencies in the specified derivations at the first type of EEG pathology. At the second type the alpha- or beta-rhythm capacity is increased both in the right frontal and left occipital derivations with the help of binaural waves with the frequencies correspondent to the calculated average frequencies in the same derivations. If in the EEG an increased slow-wave activity is available, to weaken it the binaural wave frequencies which differ from the calculated average frequencies in the derivations with the high amplitude or theta- and delta-rhythms capacity (the difference must be not less than 1-2 Hz) are selected.

The research testified that the offered method of rehabilitation is effective for soothing states of depression, anxiety at stress, computer or game addiction. At that not only the clinical status and psychophysical showings of clients are improved, but their evident positive psychic state of health becomes apparent. The application of the method allows lowering the level of anxiety indexes (according to the tests of Spielberg-Khanin and Tailor), increasing subjective (state of health, activity, mood on the test of SAN) and objective self-estimations (adaptivity on the test of Frolov, productivity, information processing rate, accuracy on the correction test of Landolt).

Sample 1. Patient V., 23 years of old. Increased anxiety, irritability, and infringement of dream. The preliminary diagnostics on EEG: desynchronization of alpha-rhythm and increased activity in the frontal parts of the cortex is registered, the average capacity of alpha-rhythm in the frontal derivations on the left is  $2,8 \text{ mcV}^2/\text{c}^2$ , on the right -  $0,0 \text{ mcV}^2/\text{c}^2$ , the average frequency in the frontal derivations on the left is 9,3 Hz. Slow waves of delta-diapason up to 125 mcV, frequency of 1,1 Hz and theta-diapason up to 55 mcV, frequency of 5,3 Hz, are detected. The average capacity of alpha-rhythm in the occipital derivations on the left is  $3,7 \text{ mcV}^2/\text{c}^2$ , on the right –  $4,3 \text{ mcV}^2/\text{c}^2$ . The average frequency both on the left and on the right is 9,8 Hz. The first type of EEG changes is defined, that corresponds to the reactive type of emotional pathology. The action was carried out by means of binaural rhythms of sinusoidal form with the help of stereo earphones. A set of two frequencies is selected: 9,8 Hz and 3 Hz. The effect time for one séance made 35 min. Ten séances were carried out.

Finally, the positive result was achieved. The anxiety had decreased. The alpha-rhythm zonality had restored. The asymmetry in the anterior regions of the cortex had been practically deleted. The average alpha-rhythm capacity in the frontal derivations on the left was  $1,1 \text{ mcV}^2/\text{c}^2$ , on the right -  $1,0 \text{ mcV}^2/\text{c}^2$ . The average alpha-rhythm capacity in the occipital derivations on the left had increased up to  $8,5 \text{ mcV}^2/\text{c}^2$ , on the right –  $8,2 \text{ mcV}^2/\text{c}^2$ . The amplitude of pathological waves had decreased up to 61 mcV.

Sample 2. Patient F., 18 years old. State of tense, lowered mood, attention and working capacity. The preliminary EEG diagnostics: agitations in the right frontal region of the cortex

in magnitudes of the alpha- and beta-rhythm average capacity are registered. The average capacity of alpha-rhythm in the frontal derivations on the left is  $3,9 \text{ mcV}^2/\text{c}^2$ , on the right –  $1,9 \text{ mcV}^2/\text{c}^2$ . The average frequency is accordingly 8,5 and 10,3 Hz. The average capacity of alpha-rhythm in the occipital derivations on the left is  $8,4 \text{ mcV}^2/\text{c}^2$ , on the right –  $7,9 \text{ mcV}^2/\text{c}^2$ . The average frequency is accordingly 10 and 10,5 Hz. The average capacity of low-frequency beta-rhythm in the frontal derivations on the left is  $0,6 \text{ mcV}^2/\text{c}^2$ , on the right –  $0,1 \text{ mcV}^2/\text{c}^2$ . The average frequency is 16,3 Hz on the left accordingly. The average capacity of low-frequency beta-rhythm in the occipital derivations on the left is  $1,7 \text{ mcV}^2/\text{c}^2$ , on the right –  $1,5 \text{ mcV}^2/\text{c}^2$ . The average frequency is accordingly 15,8 and 15 Hz. The average capacity of high-frequency beta-rhythm in the frontal derivations on the left is  $0,4 \text{ mcV}^2/\text{c}^2$ , on the right –  $0,0 \text{ mcV}^2/\text{c}^2$ . The average frequency is accordingly 28,3 Hz on the left. The average capacity of high-frequency beta-rhythm in the occipital derivations on the left is  $0,5 \text{ mcV}^2/\text{c}^2$ , on the right –  $0,5 \text{ mcV}^2/\text{c}^2$ . The average frequency is accordingly 24 and 22,5 Hz. The reactive pathology type is defined. The action was carried out by means of binaural rhythm set of the following frequencies: 10,3 Hz (the average alpha-rhythm frequency in the frontal derivations on the right, 15 and 22,5 Hz (the average frequencies of low- and high-frequency beta-rhythms on the right). The effect time for one séance made 40 min. Ten séances were carried out.

After the correction the emotional state of the patient improved, the attention and working capacity increased. Against the background of total alpha-rhythm capacity increase the asymmetry of biopotential distribution in the anterior cortex regions decreased. The alpha-rhythm zonality restored.

#### References:

1. Luchinin A.S. Psychophysiology. Compendium of lectures. – Rostov-on-Don: "Phoenix", 2004. – p.320.
2. Nebylitsyn V.D. Psychophysiological research of individual differences. – M: Nauka, 1976. – p.336.
3. Psychophysiology: Textbook for higher educational institutions / Under the redaction of Aleksandrov Yu.A. St. Petersburg: Piter, 2003. – p. 496.
4. Simonov P.V. Theta-rhythm and mechanism of quantization of engram retrieval // Memory. Trace processes. Thesis of the report at IV all Union Conference.- Pushchino, 1979, p.6.
5. Simonov P.V. Functional asymmetry of frontal neocortex and emotions // AS RAS Report, 1994. – V. 338. - № 5. – p.689.
6. Strelets V.B. Disorders of bodily machinery of sensation, affection and cogitation at some kinds of psychic pathology // Human physiology. 1989. – V.15. - №3. – p. 135.
7. Frolov M.V. Human functional state control. – M.: Nauka, 1987. – p.208.
8. Heller W. Neuropsychological mechanisms of individual differences in emotion, personality and arousal // Neurophysiology. 1993. – V.7. – p. 476.
9. Schneider F., Grodd W., Gur R.E. et al. PET and fMRI in the study of emotions // ISNIP/ - Frankfurt, 1995. – p. 76.

---

The article is admitted to the International Scientific Conference "Medical, social and economic problems of preservation of health of the population", Turkey, May, 21-28st 2007, came to the editorial office on 15.04.2007

#### AGE-DEPENDENT DYNAMICS OF ELECTROENCEPHALOGRAPHIC CHARACTERISTICS IN IDIOPATHIC ARTERIAL HYPOTENSION PERSONS

Chefranova Zh. Yu., Titova L.P., Makotrova T.A.  
Belgorod State University, Medical Department,  
Chair of Nervous Diseases and Medical  
Rehabilitation, Regional Clinical Hospital of  
Sanctifier Josaphat

Idiopathic arterial hypotension – IAH (the term is recommended by the International Statistical Disease Classification of the 10<sup>th</sup> Revision) or essential arterial hypotension (PAH), attends the life of a great number of people. According to the current information every one of three women and 25 men suffers from it; it being approximately 33% among women and 4% among men, thus, reaching about 12-15 %.

We (together with Laskov V.B. and Plotnikov V.V.) have carried out an EEG-analysis of 60 different ages IAH patients

[Chefranova Zh.Yu., 1999] found out among the medical personnel of the MPI, and 30 healthy people. Among those with IAH there were 54 (90%) of women and 6 (10%) of men. There were 3 groups defined: the first one was made up of 22 persons aged from 18 to 35 years old, the second – 18 persons aged 35-55 and the third – 20 persons aged 56-62.

The IAH diagnostics criteria correspond to traditional idea of IAH [Troshin V.D., 1991].

1. Long lasting arterial hypotension, BP numbers are lower than 105-100 and 65-60 mm hg.

2. Indications of earlier angio-hypotensive episodes available.

3. Arterial hypotension chronicity beginning with the age of 12-15.

4. Absence of anamnestic and clinical signs of chronic physical and neurologic diseases, CCT, neuroses.

5. BP figures, according to the daily monitoring (DMBP), correspond to the adopted in Europe criteria of hypotonic conditions diagnostics.

We didn't include trained female athletes and those who arrived from the Thule or highland into this group. The occupational composition was like that – doctors, teachers, accountants, employees.

The control group was made up of healthy women having no chronic diseases and CCT. The occupational composition was as follows: accountants, nurses, railway transport traffic inspectors. The three identical age subgroups, each one having 10 persons, were defined as well as in the patient group.

Physical examination of the patients was carried out according to generally accepted neurologic methods.

The average BP values made  $99\pm 0,6$  and  $69\pm 0,5$  mm hg in IAH persons in the 1<sup>st</sup> age group,  $104\pm 0,3$  и  $70\pm 0,1$  – in the 2<sup>nd</sup> one and  $106\pm 3$  and  $71\pm 2$  mm hg – in the 3<sup>rd</sup> age group. In healthy people the corresponding figures were  $120\pm 0,6$  и  $77\pm 0,7$  mm hg – in the 1<sup>st</sup> group,  $124\pm 0,3$  и  $81\pm 0,2$  – in the 2<sup>nd</sup> one and  $130\pm 0,2$  и  $81\pm 2$  mm hg – in the 3<sup>rd</sup> age group.

EEG methods. For the EEG a program-apparatus complex including the 16-channel electroencephalograph - EEG 16S, an input unit and PC were used. The EEG was carried out with the help of standard program package, including

those against the background of functional tests (opening and closing eyes, rhythmical photostimulation, CO<sub>2</sub>-withdrawal seizure).

The baseline EEG record was carried out Ante Meridiem in a screened and soundproof booth. The patient was in a special armchair semirecumbent, with the eyes closed.

The baseline EEG physiologic rhythm indexes' analysis proved the literature data that relative EEG characteristics' stability remains unchanged in healthy people up to about 50. From that very period the EEG specter alteration, which is manifested in alpha rhythm representativeness decrease and slow delta rhythm index increase [Chugunov S.A., 1950; Zenkov L.R., Ronkin M.A., 1991, and others], occurs. The physiological rhythm index dynamics, with the age increase, in the IAH patients was like that in the healthy examinees' group, but manifested itself much earlier (since 36).

The physiological rhythm indexes in IAH and healthy persons statistically authentically differ in the juvenile age with greater alpha rhythm representativeness in IAH patients. In the middle of life the index differences evanesce, and late in life the statistically authentic alpha rhythm representativeness decrease and slow theta rhythm increase become apparent, that testifies to brain activation power decrease [Leitis N.S. and others, 1980; Izyumova S.A., 1980; Mori F., 1973, and others].

The correlation coefficient of fast and slow waves (C f/s) remained steady up to 55, after that it authentically decreasing on account of slow wave component; it testified to the age-dependent weakening of CNS activation level [Golubeva E.A. and others, 1974].

The C f/s age dynamics in the baseline record in IAH patients is like that in healthy examinees, but the absolute C f/s value marked in healthy people after 55 is reached by IAH persons by 36 already.

The CO<sub>2</sub>-withdrawal seizure test in IAH persons has shown up the C f/s decrease in the juvenile age already with the aggravation of this phenomenon in older age groups. The C f/s differences between healthy and IAH persons become apparent in the middle age and grow much more late in life.

The opening-closing eyes test authentically showed up the low alpha-activity inhibition level at IAH late in life; in 55% of these people the

reaction assumed an invert character in the form of alpha rhythm appearance, with its absence or weak representativeness in the baseline EEG, that testifies to the originally low FS brain level [Rusinov V.S., 1960; Mayorchik V.Ye., and others].

The photostimulation driving rhythm had no essential differences in healthy and IAH persons.

As the result of the research we have stated that the EEG characteristics of practically healthy people in different age-dependent stages are steady and change with the increase of years very little, only in the elder age group an alteration of the EEG baseline structure occurs: the alpha rhythm representativeness decreases, the slow delta rhythm index grows, the C f/s decreases, the flicker-light enforced rhythm assimilation weakens. In IAH patients these alterations are more vivid and are manifested already in the middle age group (from 35) and considerably increase in the elder one, that testifies to the CNS activation level decrease and nervous processes inertness increase.

From now forth, under a new examination of more people we succeeded to specify the EEG alterations in various age periods both at IAH and in apparently healthy people.

Totally, we included 190 people into the research: 110 – with IAH and 80 –apparently healthy. The groups' membership was as follows: the first one – 40 persons aged from 18 to 35; the second – 40 persons aged from 36 to 55 and the third one – 30 persons aged from 56 to 62.

The groups of comparison contained accordingly 30, 30 and 20 persons and consisted of clinically healthy people of the same age categories.

As the result of this new extended investigation we have noticed that with the increase of years alpha rhythm representativeness decreases authentically and sharply, and simultaneously, theta- and especially beta rhythm representation (that was not evident during our first investigation) increases. There were statistically authentic alterations of the specified aspect between the 1<sup>st</sup> and the 2<sup>nd</sup>, the 1<sup>st</sup> and the 3<sup>rd</sup> groups of patients. The index correlation coefficient of fast and slow waves decreased both at baseline records and the CO<sub>2</sub>-withdrawal seizure test.

In IAH persons we have distinguished still more sharp than in the healthy, alpha rhythm representativeness decrease in the 2<sup>nd</sup> and 3<sup>rd</sup> groups, but in the 1<sup>st</sup> age group the alpha rhythm representativeness index, as well as at the previous our investigations, was authentically higher in IAH patients than in healthy ones of the same age. At the same time beta- and theta rhythm representativeness increased significantly. Both in IAH and healthy persons the index correlation coefficient of fast and slow rhythms decreased in the baseline EEG and at the CO<sub>2</sub>-withdrawal seizure with the increase of years.

According to beta rhythm representativeness the 1<sup>st</sup> and 2<sup>nd</sup> IAH groups fall behind and the 3<sup>rd</sup> one outruns the corresponding groups of healthy persons. The correlation coefficient of fast and slow rhythms was authentically lower than in healthy persons both in the baseline EEG and at the CO<sub>2</sub>-withdrawal seizure in the 1<sup>st</sup> IAH group persons.

The inhibition degree of alpha-activity in patients with IAH in every group is considerably lower than in healthy people.

There were no other distinct and statistically valuable EEG alterations with the increase of years noticed.

Thus, the structure of bioelectrical brain activity with the increase of years suffer changes both in apparently healthy and IAH people, however, at IAH the behavior of changes has got peculiarities reflecting, as it should seem, the function and cerebral formations' microstructure singularity. Alongside with this, there are authentic variations from the standard in IAH persons in the juvenile age already, that can be the effect of residual pathology and also the result of cerebral blood supply peculiarities against the background of dysontogenesis.

**References:**

1. Zenkov L.R. Clinical electroencephalography with elements of epileptology. M.: MEDpress-inform, 2002.
2. Laskov V.B. Dynamics of clinical-neurologic characteristics at primary arterial hypotension in age-dependent aspect / Laskov V.B., Plotnikov V.V., Chefranova Zh.Yu. // Problems of psychiatry, psychosomatics, addictology: scientific conference materials – Kursk, 1998.

3. Laskov V.B. Preliminary results of primary arterial hypotension neurophysiological research / Laskov V.B., Zhuravlyova T.V., Chefranova Zh.Yu. // On history of Mtsensk public health service and peripheral issues of secondary. – Oryol, 1997.

---

The article is admitted to the International Scientific Conference “Problems of the international integration of national educational standards”, Paris-London, April, 20-27th 2007., came to the editorial office on 08.02.07



### Shot report

#### IMMUNE FUNCTIONS OF THE BRAIN

Parakhonsky A.P.

*Kuban medical university, Center of quantum  
medical «Health»  
Krasnodar, Russia*

Integrative activity of all brain sections results in the most surprising among all neurobiological phenomena - psychics. Besides this unique brain function, another one was determined - a participation in very complicated process of immunity. The concepts about the role of a brain in induction and regulation immune responses underwent radical changes last years. It was found that cerebrospinal fluid (CSF) is settled with T- and B-cells, which are not homogenous, subdivided into subsets (subpopulations), perform specific immune functions and are able to develop a local immune response in CSF and CNS (6). Subpopulations of T- and B-lymphocytes are programmed for certain immunological functions (1,5,6). Functional characteristics of blood and CSF (5,6) lymphocytes are almost identical. In health and disease of CNS there were found immunoglobulins (Ig) of various classes. There are evidences for a local synthesis of IgG in CNS. IgG synthesis has been reported in more than 90% patients with multiple sclerosis and subacute sclerosing panencephalitis. Ig and neurotransmitter synthesis by cells of CSF was shown (2,5). Thus, occurring in CSF cell populations and proteins take part in generation of various immune responses and realize the immunological surveillance in subarachnoid space, i.e. form immune barrier of the brain.

Also non-lymphoid ones: neuroglial cells (astrocytes, oligodendrocytes, microglia) and endothelial cells of brain vessels take part in immunological reactions in CNS. The studies have shown that astrocytes function as auxiliary cells mediating the immune reactions in brain tissue (2,3,6). Like macrophages astrocytes can synthesize and secrete interleukin-1 (IL-1). It is established that astrocytes in patients with multiple sclerosis can present antigens to T-cells and stimulate their proliferation during sensibilization and turning

into cytotoxic lymphocytes. It was found that prostaglandins produced by astrocytes exhibit neuromodulating function. Produced by T-lymphocytes interferon induces marked increasing of antigen expression on glial cells of the brain *in vivo* and *in vitro* and results in appearance of Ia-antigens on astrocytes. As a result, glial cells can induce immune reactions and acquire sensitivity to lyses by cytotoxic T-lymphocytes. It is also shown that glial cells can induce interferon to be considered as one of the mediators taking part in immune response. Cytotoxic cytokines against oligodendrocytes were found. These cytokines seem to take part in processes of demyelination in autoimmune diseases. Microglial cells are capable of stimulation, phagocytosis and expression on their surface Fc-receptors for Ig. In favour of immune functions of neuroglial cells serve evidences of their infecting with human immunodeficiency virus, which affects as it is known, only immunocompetent cells bearing CD4 antigen on the surface membrane. It was found that such cells in CSF are T-helpers, macrophages and monocytes while in itself nerve tissue - non-lymphoid cells of CNS: microglia, astrocytes and oligodendrocytes, which bear Ia-antigen on the surface and contain mRNA encoding CD4 protein.

Presence in astrocytes both classes of molecules of the major histocompatibility complex provides with it a full range of functioning as the cells, representing antigens T-lymphocytes. Binding of CD4-lymphocytes by astrocytes is the first stage of immune response initiation in CNS. Activated CD4-cells to produce interferon- $\gamma$  (IFN- $\gamma$ ), which in turn induces astrocytes. These cells express HLA-DR antigens and produce IL-1, activating new T-cells. As a result there is an intensification of immune reactions in CNS (2,3).

For activation of CD4-lymphocytes, their physical binding with antigen-presenting cells - astrocytes of CNS, is necessary. Cells of vascular endothelium express Ia-antigens and can stimulate lymphocytes, taking active part in the development of immune reactions in CNS. In various CNS diseases the different types of

adhesive molecules on the surface of lymphocytes, monocytes, macrophages and endothelial cells were found. These molecules are binding firmly on the membranes of lymphocytes and granulocytes attracting them into inflammation foci of the brain tissue. Adhesion molecules occur on the membranes of endothelial cells in low concentrations; their expression appreciably increases in pathology of nerve system (multiple sclerosis, neuropathies), that promotes an in draft of immunocompetent cells to the inflammation focus.

By means of neuropeptides the brain regulates not only nerve and endocrine systems, but also immune system. The discovery of immunomodulating characteristics of neuropeptides has radically changed the ideas about mechanisms signal transmission from nerve system to immune one. Receptors to neuropeptides were found on the immunocompetent cells, that confirmed their participation in the realization of efferent link of neuroimmune interaction (1,4). On the cells of nerve system there were found the receptors to immunopeptides and cytokines, synthesized by immune cells, i.e. a functioning of afferent link in immune-nerve interaction was revealed. The opioids (immunopeptides), synthesized by nerve system, act on the receptors of nerve cells (3). At present, the existence of diffuse cell system regulating and coordinating a great number of special functions by means of peptide secretion is generally accepted.

A wide distribution of neuropeptides outside the brain and presence in nerve tissue of hormone, considered in the past as hormones of peripheral endocrine glands, have under lied of conception about diffuse neuroendocrine system, which suggests an integration of nervous and humoral regulation both on the level of CNS and on periphery. Under normal conditions interrelation and interaction between nerve, immune systems of the brain and general immune, endocrine systems are realized by hormonal factors: mediators, hormones, neuro- and immunopeptides, cytokines, synthesized in cells of nerve, immune and endocrine systems and passing free through the intact blood-brain barrier.

Cytokines are heterogenous group of low molecular weight glycoproteins synthesized and secreted by various cells of immune and nerve systems, and realizing regulatory functions.

Cytokines are binding with appropriate receptors on target cells and regulate activation, differentiation and proliferation of immunocompetent and other cells. It is shown that such cytokines (interferons, interleukins, tumor necrosis factor (TNF) and others) take part in functional regulation of endocrine, nerve and immune systems. Peptides and cytokines realizing neuro-immune-endocrine interaction have common receptors. Structural similarity of receptors was shown for IL-1 and IL-2, endorphins, ACTH. Cytokines are the main regulators of complex intercellular interactions in nervous and immune systems. Disturbance of regulatory processes mediated by cytokines can promote the rise of several severe diseases of nerve system (demyelinating and infections). It is of great importance that cytokines pass easily through the blood-brain barrier in both directions. They are the main mediators of neuro-immune interrelations (3).

Among numerous biological effects interferons (INF) is also its excitant action on neurons. Participation of INF- $\alpha$  in neuroimmune interactions has also been shown. INF- $\gamma$  provokes an expression of Ia-antigen on astrocytes. INF has a wide spectrum of biological effects including psychophysiological ones. Interleukins (IL-1, IL-2) takes part in homeostasis regulation in CNS, regulates hypothalamus and hypophysis functions as well as level of endorphin, corticosteroid and ACTH in blood. IL-1, produced by astrocytes and microglial cells, induces secretion of hypothalamic corticoliberin which influences the functional activity of hypophysis. Analgetic effect of IL-1 $\alpha$  evidences the neurotropic action of this cytokine. IL-2 and its receptors were found in brain extracts in viral and autoimmune diseases. Cells secreting IL-2 were found in the brain of health animals. IL-2 induces proliferation and differentiation of oligodendrocytes, increases reactivity of hypothalamic neurons (1,3,4), influences the functional activity of hypophysis. IL-6 produced in CNS promotes the differentiation and antibody-forming of B-cells migrating into foci of viral and bacterial affections of CNS. Like IL-6, tumor-necrosis factor (TNF- $\alpha$ ) is produced in CNS by glial cells and is determined in CSF of patients with viral and bacterial meningitis, multiple sclerosis, AIDS-dementia and others. In aggravation of multiple sclerosis there is

increasing of TNF, its level being correlated with the course of disease.

Summarizing the above data it can be concluded that the brain realizes immune functions by means of three morphologically and functionally different subsystems: the first one is represented by lymphoid cells of CSF (T-, B-cells and their subpopulations), natural killer cells, monocytes and macrophages; the second one is represented by non-lymphoid cells of nerve tissue - microglial cells, astrocytes, oligodendrocytes and cells of vascular endothelium; the third subsystem is represented by humoral factors, biological active substances - mediators, peptides, cytokines and others. Thus, analysis and generalization of literature and our clinical-experimental data change our notions about the role of brain in immune response. The presence in the brain of high-effective set of lymphoid and non-lymphoid cellular elements and their products allows to consider that, besides the realization of very complicated psychical functions, the brain not only takes part in generation and regulation of immune response in CNS and general immune system, but also itself is one of the organs of immune system.

**References**

1. Abramov V.V. Complex mechanisms of interaction of immune and nervous systems. The auto abstract of the doctor medical sciences. - Moscow, 1994. -38p.
2. Floz W., Fontana A., Wokerle H. Interaction of astrocytes with the immune system. // Immunology. 1985, vol.165, N3/4, p.259-265.
3. Fontana A. Production of cytokines in the central nervous system. //J. Neuroimmunology. - 1994, suppl.1, p.61-63.
4. Kvetnoy I.M. et al. //The bulletin of formation and development of a science of the RANS. – 2001, vol.5, N.2, p.151-159.
5. Manko V.M. Immunocompetent human cells subpopulation characteristic. In: Immunocompetent cells of human cerebrospinal fluid. - Tbilisi, 1991. p.8-50.
6. Sepiashvili R.I. Bases of physiology of immune system. - Moscow, 2003. -240p.

**ROLE OF IMMUNE DAMAGES IN THE NEUROLOGIC PATHOLOGY**

Parakhonsky A.P.

*Kuban medical university, Center of quantum medical «Health»  
Krasnodar, Russia*

Cerebrovascular pathology still has an enormous impact on public health of every nation. It is ranking among the leading causes of serious disability. One of the most unfavorable forms of disability that has the greatest social value is dementia. Epidemiological studies have identified 46 persons with vascular dementia (7,3%) and 14 persons with probable Alzheimer’s disease (1,2%), mean age 50,4±6,7 years. Identification of the main causes contributing to the development of dementia and elaboration of early preventive measures is the issue of great importance. Studies conducted give us an opportunity to define and analyze the factors influence on the development and outcome of cerebrovascular dementia and probable Alzheimer’s disease. We believe that these researches will have increasing importance.

Recently object of research HLA of system were HLA antigens. HLA antigens were investigated in various human populations. After establishing the method of polymerase chain reaction, opportunities emerged to explore the different sections of DNA and the genes that are located in these sections. Molecular-genetic methods of research extremely enlarged our knowledge of alleles, especially those of class III and its polymorphism. The last hypothesis about HLA structure has been reviewed (6). Genes of class III in comparison to genes of classes I and II are not fully researched. Genes of class III are located in the space between genes of classes I and II of HLA system and have important biological functions (7). Investigation of polymorphism of genes of class III (HLA) system is of great importance for the problem of HLA and cerebrovascular pathology, as well as for problems of neurological and immunological memory and perspectives of rehabilitation of such patients (4). Recent investigation revealed a large number of new genes belonging to the class III (HLA) system.

Our aim was to determine the concentration of cytokines TNF- $\alpha$ , TNF- $\beta$  encoded by genes A and B of the locus of TNF in blood serum and cerebrovascular fluid of patients

with cerebrovascular dementia and probable Alzheimer's disease, also in patients with cerebrovascular pathology without dementia. Recent investigation show that cytokines TNF- $\alpha$  and TNF- $\beta$  synthesized by genes of TNF locus actively participate in the formation of severe pathological processes in the human organism. TNF- $\alpha$  is synthesized by various cells, while TNF- $\beta$  is produced by lymphocytes only.

Fifty-two patients aged 40-67 years were investigated. 14 patients were with probable Alzheimer's disease, 28 patients had vascular dementia. 10 patients had vascular pathology without dementia. These 10 patients composed a control group. The rate of dementia was defined by application of MMSE. The diagnosis of probable Alzheimer's disease was made by exclusion, in accordance with NINDS-ADRDA criteria.

A blood sample was taken from elbow venue. Lumbar punctures were performed in the L4/L5 interspace. Serum levels of TNF- $\alpha$  and TNF- $\beta$  were measure by a competitive enzyme-linked immunosorbent assay (ELISA). The working range of ELISA assay was 0,60-2,50 ng/ml. It is shown, that the levels of TNF- $\alpha$  and TNF- $\beta$  in serum and CSF in the control group in patients with probable Alzheimer's disease do not differ significantly. In patients with vascular dementia, the levels of TNF- $\alpha$  and TNF- $\beta$  are increased as compared to the control group and the group with probable Alzheimer's disease ( $p < 0,0001$ ;  $p < 0,05$ ). The result show that in cases of vascular dementia the serum and CSF levels of TNF- $\alpha$  and TNF- $\beta$  are increased. Elevations of these levels indicate that cytokines, in particular, TNF- $\alpha$  and TNF- $\beta$ , play an important role in the development of vascular dementia. It might be linked to the toxic impact of TNF- $\alpha$  and TNF- $\beta$  in the brain tissue.

As it is know for recent investigation, cytokines TNF- $\alpha$  and TNF- $\beta$ , synthesized by genes A and B, have a great influence on inflammation processes. Cytolytic and cytotoxic effects mediated by them against the neurons of subcortical structures and endothelial cells of microvessels emphasize important biological functions of genes A and B of TNF locus and cytokines synthesized by them.

The possibility of several pathological disorders in human caused by impairment in the in the structure of genes, which are localized next to genes of classes I and II of HLA complex, or

by functional activity of albumen products encoded by them, was well known in neuroscience (1,2).

The result obtained show biological importance of genes of TNF locus class III HLA system and by them encoded TNF- $\alpha$  and TNF- $\beta$  in the pathogenesis of vascular dementia. It is possible that albumen products of genes TNF participate in the intracellular processing of antigens. According to our result, cytokines TNF- $\alpha$ , TNF- $\beta$  and genes A and B of class III of HLA system are not involved in the pathogenesis of Alzheimer's disease.

Literature about peripheral nervous disorders show the examples when neither axon structural abnormalities nor demyelination occur. The major change in these disorders is in ion channels of peripheral nerves. This is analogous to the ion channelopathies establishes in the etiology of hereditary muscle diseases. Ion channels may be infected by toxins, antibodies, metabolic factors. Partial blocking of Na<sup>+</sup> channels results in slowing of nerve conduction velocity without conduction block, decreased nerve action potential amplitude in the absence of histologic demyelination. Antibodies directed at Na<sup>+</sup> channels in demyelinating diseases are receiving increasing attention.

According to these data, we aimed to investigate the role of the pathology of Na<sup>+</sup> and K<sup>+</sup> channels in the pathogenesis of neuropathies and polyneuropathies and elaborate a new approach to the treatment of these pathologies.

Epidemiological research has been executed to show expansion of neuropathies and polyneuropathies. 262 patients were investigated, among them 175 men and 87 women aged from 14 to 78 years. In 38 patients, polyneuropathy was identified. 27 patients showed Guillian-Barre syndrome of chronically allergic origin and in 12 patients diabetic polyneuropathy was identified. In patients who suffered from Guillian-Barre syndrome conduction of action potentials in the nerves was reduced. Electromyography research showed slower nerve conduction and decreased nerve action potential amplitude was noted along with axonopathies. We consider that it reflects the blockade of voltage Na<sup>+</sup> channels by antibodies.

As it is well known, the chemical structure of neurons membrane and the structure of their axons are different. Neuron membrane consists of lipids, proteins and polysaccharides (3,5) that are in the close interrelation with water. Water

around the neurons include ions and metabolic factors. The electrical activity of the membrane depends on intracellular concentration of  $\text{Na}^+$  and  $\text{K}^+$  that is balanced by  $\text{Na}^+$  channels and by conduction of stimulus at some nodes.

Clinical and electrophysiological data obtained allow us to suppose that in mononeuropathies and polyneuropathies, function of  $\text{Na}^+$  and  $\text{K}^+$  channels are impaired and may play a leading role in the pathogenesis of polyneuropathies. Apparently, the pathology of ion channels plays an important role in the pathogenesis of axonopathy. Pathophysiologic abnormalities of ion channels cause an atonal degeneration with demyelination, distal axonopathy and impairment of the function of peripheral nerves. There is now extensive evidence for peripheral nerve dysfunction. Abnormalities of peripheral nerve  $\text{Na}^+$  and  $\text{K}^+$  channels result in a diversity of clinical and electrophysiological phenomena.

At patients with diabetic polyneuropathies, the sensory fibers were mostly affected. The role of antibodies directed at  $\text{Na}^+$  channel blockade may play an important role in conduction slowing and blocking occurs. Antibodies can suppress voltage-sensitive  $\text{Na}^+$  currents, block  $\text{Na}^+$  channels and disrupt the membrane (3).

In 20 patients with Guillain-Barre syndrome we apply an immunomodulator Plaferon-LB, along with leucoplasmapheresis. Plaferon was given at a dose of 0,05-1,0 mg protein/kg for 15 days. 17 patients were treated traditionally with leucoplasmapheresis. In this group, 5 patients (29%) recovered fully. Improvement could be detected in 9 (52%), while

in the group treated with Plaferon-LB and leucoplasmapheresis 7 (70%) showed full recovery. According to the result obtained, we consider that pathology of ion channels may play an important role in the pathogenesis of demyelination diseases. Application of immunomodulation may reduce the level of antibodies that block the  $\text{Na}^+$  channels. Immunomodulator Plaferon-LB suppressed the autoimmune processes and autoaggression thus promoting to restoration of the function of ion channels.

#### References:

1. Blenow K. et al. Ubiquity in cerebrovascular fluid in Alzheimer's disease and vascular dementia. //Int. Psychogeriatrics. -1997, N.9, p.51-59.
2. Erkinjuntt T. Vascular dementia: challenge of clinical diagnosis. //Int. Psychogeriatrics. - 1997, N.9, p.49-51.
3. Hille B. Ionic Channels of Excitable Membranes. -Sunderland. MA: Sinauer Associates, 1992. -387 p.
4. Malashkhia Y.A. et al. Problems of neurological and immunological memory and perspectives of rehabilitation. //Int. J. on Immunorehabilitation. -1999, N.3, p.29-34.
5. Neretin V.Y. et al. Infectious allergies polyradiculoneurites Guillain-Barre. //J. Neuropathol. -1997, N.3, p.111-114.
6. Olaveson M.G. et al. Characterization of novel gene in human MHC class III region. - In.: HLA 1994. - Oxford University Press, 1995. - p.190-192.
7. Sargent C.A. Molecular Mapping of the HLA class III region. - Thesis. 1998. - p.287.

*Shot report*

**DEDUCTION OF EUCLID STATEMENT  
ABOUT PARALLEL LINES  
INTERSECTION AS THEOREM**

Lokhov R. Ye.

*Institute of International Academy of Technical  
Sciences  
Vladikavkaz, Russia*

A classical Greek mathematician Euclid formulated a statement about two parallels intersection [1] in the third century B.C. However, the failure of the efforts to apply purely geometric images and premisses for its deduction as a theorem has made Euclid refer the statement to the number of axioms.

The efforts to prove the fifth axiom took two thousand years. Only by 20-30s of XIX century thanks primarily to the works of Lobachevsky N.I. and also Boyom J., Gauss K. and others [2] a new non-Euclidian geometry – hyperbolic geometry of Lobachevsky - was created [2, 5]. For this it was necessary to give up on the fifth axiom and to offer instead of it the fact that ***through a point out of a given line pass at least two lines parallel to the given one.***

The angular sum of a big enough triangle constructed on three parallel lines can have as small as we please angular sum (less than  $180^\circ$  (geometry of Lobachevsky) or more than  $180^\circ$  (spherical geometry of Riemann)). In small dimensionality domains such a geometry is almost undistinguishable from Euclidian one.

$$AC = 1/\text{tg } \gamma \approx 2.06 \times 10^5 \text{ m.} \quad (1)$$

However, both noted above logical reasoning and numerous other ones [2-5] are very little applied to the deduction of the Euclid statement as a theorem. To our opinion, the main cause of it – is the scholastic attempts of application purely geometric images and premisses for it.

For the Euclid's statement deduction let us construct a cone **ABDC** by rotating the right

Therefore, at present the statement of Euclid has not been proved yet. It is clear that it is possible to make infinitely many geometries as well as logical systems. Only one thing remains unclear – which of them is realized in the surroundings? And aren't some of them realized within the frames of Euclidian geometry itself, i.e. in geometrically small dimension?

The purpose of the given work is to prove the statement of Euclid as a theorem on the ground of the old system of postulates and axioms (synonyms). For this we formulated the statement of Euclid in the form of a theorem: *every time when a line being intersected by two other lines forms inside angles with them the sum of which is equal to two right ones, these lines are crossed from that very side from which these angles are altered equally.*

**Deduction.** Let us assume that in accord with Euclidian axiom the distance between crossing points **A** and **B** of a line with two other lines **a** and **b** with inside angles  $\alpha$  and  $\beta$  equal to the sum of the two lines is 1m. Let us assume that the lines **a** and **b** are crossed somewhere in the point **C** (Picture1) and in the formed right triangle **ABC** whose angles  $\alpha$  and  $\beta$  are almost right ( $89^\circ 59' 59''$ ), the apical **C** angle  $\gamma$  is one angle second altered ( $1''$ ). Then the right angle side **AC** or **BC** has approximately the distance (equation 1):

triangle **ABC** (picture.1) near one of its sides and match the central points **XYZ** with the point **C** (Picture 2).

Let us assume that upon the condition of a zero alteration of the inside angles of the lines **AB**, **AD** and **BD**, the squared distance of the right angles' sides **AC**, **DC** and **BC** (**dl**)<sup>2</sup> is equal to **[2]**:

$$(\text{dl})^2 = dx^2 = dy^2 = dz^2, \quad (2)$$

where  $dx$ ,  $dy$ ,  $dz$  are the differentials of the coordinates.

Let us consider the processes really taking course in the Dekart coordinates of the Euclidian space. For example, light-induced reactions, diffusion bounded processes in the shot of a

multienzyme complex, and others [6-8], in which the number of successful collisions leading to final products for an average time  $\Delta t = 10^{-10}$  sec is  $10^{10}$ , are referred to such ones.

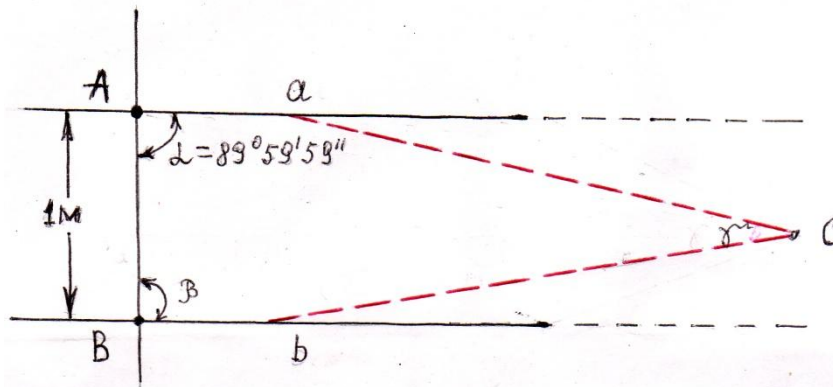

**Picture 1.** When the lines **a** and **b** are less than one angle second altered the length of the right angle side **AC** grows up to astronomic sizes relative to the side **AB**. At more than 1" alteration of the lines **a** and **b** the length of the side **AC** or **BC**, vice versa, reduces.

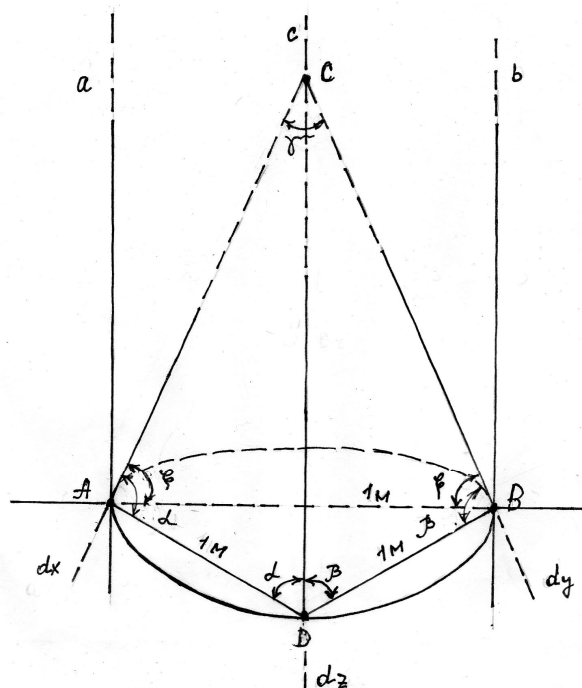

**Picture2.** Through the three points **A**, **B** and **C** on a circle go three parallel lines **a**, **b** and **c** with the distance of 1 m from each other. Let us assume that in every of the three inside opposite angles  $\alpha$ ,  $\beta$  and  $\xi$  of the right triangles **ACD**, **ACB** and **DCB** a two angle seconds ( $2''$ ) less than  $90^\circ$  circle perimeter alteration takes place. Then the sum of all the three inside angles  $\alpha$ ,  $\beta$  and  $\xi$  will be six angle seconds ( $6''$ ) less than  $360^\circ$  (3), and the apical **C** angle of the right cone is equal  $\gamma = 6''$ .

Operating with these conditions the hypothetical area of the circle perimeter of the cone **CABD** can be calculated from the formula (3):

$$(2\pi R)^{10} \times 1/\operatorname{tg}\gamma, \text{ или } 10^{10 \lg 2\pi R} \cdot 1/\operatorname{tg}\gamma = 0,3218 \times 10^{10} \text{ m}^2, \quad (3)$$

where the cone base radius  $R = 0,5 \text{ m}$ ,  $\gamma = 6''$ .

The analysis of the formula (3) points to a flexible character of the alteration of the inside angles of the intersection lines **AB**, **AD** and **BD** with the lines **a**, **c** and **b**. Because of different geodesic flat distribution of the last, the chance of the intersection of **a**, **c** and **b** in the scale of three-dimensional space (Picture 3) is extremely ignoble.

A great number of chemical processes taking course while forming geometric space in living systems are known in literature [8]. The rate of these processes behavior is determined exceptionally by the collision frequency of the reacting elements [6-8].

However, in a respectively large scale of **XYZ**-coordinates the chance of the particles' collision is so ignoble that it can be taken for 1. But changing from a three-dimensional system to a two-dimensional system of coordinates the collision frequency of the reacting particles grows tenfold, and to a one-dimensional system – 100-fold [8].

It is known that diffuse reactions have got three-dimensional distribution. For example,  $10^{-10}$  mols of adenosine triphosphate (ATP), adenosine diphosphate (ADP) and phosphate (Pi) mixture are distributed in the body in the following concentrations:  $[\text{Pi}] = 10^{-2} \text{ mol}$ ,  $[\text{ATP}] = 10^{-3} \text{ mol}$

and  $[\text{ADP}] = 10^{-5} \text{ mol}$  [9]. The content of ADP normally is always more than that of ATP.

From about 100 000 encoding and they are distributed in the three-dimensional system of coordinates in molecular ratios as  $10^{-5} \times 10^{-3} \times 10^{-2}$ .

The analysis of the expressing genes number depending on their specialization shows that about 50% of all informative (template) mRNA of an animal and human body cell is represented by one kind of the mRNA; about 35% - by a wide range of the mRNA kind and 15% - by not more than 7-8 mRNA kinds [10].

The first mRNA fraction (housekeeping) serves as templates for cellular protein synthesis. The rest two mRNA fractions are referred to "luxury" genes and provide only specialized functions.

Then, from the given above data and the fact that the Universe is asymmetrical in itself [6, 11], one can conclude: the circle perimeter area of the cone **CABD** in  $0,32 \times 10^{10} \text{ m}^2$  (3) in the three-dimensional space is distributed asymmetrically. The change from a three-dimensional system to a two-dimensional and further to one-dimensional system of coordinates is attended both with the alteration increase and matching of the inside angles of the line intersection with the other two lines.

$$\begin{aligned} dx- dy: & \times 10^5 \text{ m}^2; \\ dx- dz: & \times 10^3 \text{ m}^2; \\ dy- dz: & \times 10^2 \text{ m}^2. \end{aligned}$$

It is meant that the chance of the intersection of the lines **a**, **c** and **b** increases considerably with the area volume reduction in the space of Euclidian, but not non-Euclidian geometry.

It is also follows from the fifth postulate that: if the lines **a** and **b**, at an intersection with a third line, form inside angles with it, the sum of which is less than  $180^\circ$ , these lines will certainly be intersected from that very side of the line, with

which this angle sum is less than one of two right angles.

This statement of Euclid bears purely logic loading which has no geodesic substantiation. For example, let us assume the line **AB** (Picture3) as an X-axis, and  $\alpha$ - and  $\beta$ - as the line inclinations to the X-axis. Then, from the values of slope ratio of the lines **a** and **b** to the X-axis (**AB**) equal to

$$\operatorname{tg} \alpha = -2,1445 \quad \text{and} \quad \operatorname{tg} \beta = 0,58,$$



one can conclude that the lines **a** and **b** cannot be intersected as they lie in different angular coordinates.

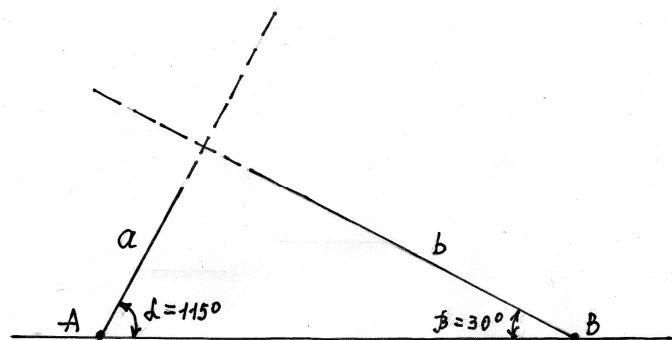

**Picture 3.** The lines **a** and **b** cannot be intersected in space because of different geodesic coordinates of distribution.

In geometries of Lobachevsky and Riemann the squared distance between nearly points  $(x^1, x^2)$  и  $(x^1+dx^1, x^2+dx^2)$  is determined by the congruence (4):

$$(dl)^2 = \delta_{ik}(x) dx^i dx^k \quad (4)$$

where  $\delta_{ik}$  is a template tensor, defining the structure of geometry.

The study of the  $\delta_{ik}$ -dependence on the coordinates allows proving that the space of finite extent, but having no limits, possesses curvature. The indexes **i** and **k** ( $i= k= 1, 2, 3\dots$ ) exactly rest on different disturbance values of the inside angles of the triangle [2].

In its turn, in the introduced by us deduction of the Euclidian statement about parallel lines intersection  $(dl)^2$  from the point  $x^1, x^2$  to  $x^1+dx^1, x^2+dx^2$  also possess curvature, but its geodesic parameters are the straight lines (5)

$$(dl)^2 = (dx^1)^2 + (dx^2)^2, \quad (5)$$

as  $\delta_{ik}$ -template tensor of the Euclidian space is exclusively defined by equal flat alteration angles, which was to be proved.

It is important to emphasize that in the present work the question is about a new geometry which is really implemented in the close round us two- and three-dimensional Euclidian space.

**References:**

1. Euclid "Beginnings", III century B.C., book IX, theorem 20.
2. Logunov A.A. "New idea of space, time and gravitation". "Science and Mankind", "Znaniye", M., 1988, pp.173-185).
3. Mathematiccal encyclopedia (red. Vinogradov Yu.V. Soviet Encyclopedia, Moscow, 1982, pp. 398-405).
4. Mathematical encyclopedic dictionary (red. Prokhorov Yu.V. Soviet Encyclopedia, Moscow, 1988, pp. 324-327).

5. Shirikov P.A. Brief foundations of Lobachevsky geometry, (the 2-nd edition, Moscow, 1983).
6. Karava Ya. Biomembranes (Higher School, Moscow, 1985, p.234).
7. Dewar M. I. S., Dougherty R. C. The PMO Theory of Organic Chemistry. A Plenum (Rosetta Edition, New York, 1975).
8. Moelwyn- Hughes E. A. The Chemical statics and kinetics of Solutions (Academic press, London- New York, 1971).
9. Alberts B. A., Bray D., Lewis I., Roberts K., Watson I. D. Molecular Biology of the Cell (Garland Publishing, Inc. New York- London, 1983).
10. Lewin B. Cell (I. Wiley and Sons, New York- Toronto- Singapore, 1983).
11. Adair R. The Great Design: Particles, Fields and Creation (Oxford University Press, 1987).

### EVIDENCE FOR DETERMINATION PRINCIPLE IN TERMS OF PHOTOSYNTHESIS

Lokhov R. Ye.

*Institute of International Academy of  
Technical Sciences  
Vladikavkaz, Russia*

Here the concept is settled that spontaneous chemical transformations are realized according the determination principle. In particular, at light quantum ( $\gamma_{II}$ ) "emission" from the activated photosystem  $P680^*$  to pheophytin, a breakdown of  $\gamma_{II}$  into electron-positron pair according to the law of charge parity nonconservation takes place. A passage between two equal spin multiplicity electron states  $S_1 \rightsquigarrow T_1$  is in competition with  $CO_2$  assimilation in  $C_3$ - and  $C_4$ - plants.

**Key Words:** assimilation of  $C_3$ - and  $C_4$ - by plants; indetermination principle; determination principle; charge parity nonconservation; electron-positron pair.

In 1935 Yukava Kh. [1], founding on Heisenberg indetermination principle discovery [2], made a guess about the existence of particles responsible mainly for internuclear forces, which are 300 times as heavy as an electron mass.

In 1947 Powell C.F. with colleges [3] experimentally proved the existence of these particles-pi-mesons with mass numbers 273,3 for  $\pi^+$  and  $\pi^-$ , 264,3 for  $\pi^0$ , that served a serious argument in the affirmation of the indetermination principle itself.

Again, in 2006, while working [4] we stated a concept in accordance with which

spontaneous chemical transformations most often are realized on the determination principle. In the same year a new photosynthetic system functioning mechanism, at the heart of which there is the concept of light quantum breakdown ( $\gamma$ ) into an electron and a positive ion ( $e^-$  and  $e^+$ ) at  $\gamma$  "emission" activated by  $P680^*$  photosystem to pheophetin in accord with the law of charge parity nonconservation [5, 6], was offered.

The offered work contains extra arguments for both determination principle discovery and light quantum breakdown on the law of charge parity nonconservation.

#### I. A breakdown $\delta\gamma_{II}$ into three electron masses, not four ones, happens

Photosynthesis of green plants is a complex biological process comprising a great number of conjugative oxidation-reduction reactions [7,8]. Cells of higher plants and Cyanobacteriae contain photosystems PII and PI, photosensitive pimentos – chlorophylls (a, b, c, d), carotenoids and phycobilines.

The photosystem  $P680$ -683 (b-pigment) absorbs the light quantum within the field of 680-683 nm, transiting into the state of excitement for about  $10^{-12}$  sec [8]. The stay time of the b chlorophyll in the excited state is infinitesimal on account of quick  $10^{-15} - 10^{-19}$  sec "emission" of the electron to pheophetin (PHEO) and further on to the centers of primary plastochinon electronic acceptor  $Q_A$  and secondary chinon acceptor  $Q_B$ . The electron transfer from the PII photosystem onto plastochinons (PQ) happens for  $2.0 \times 10^{-6}$  sec (Figure 1).

The noted above sketchy description of the photosynthesis first stage activation can be written in the form of the following inequation:

$$\sum_{i=1} (\Delta t)_k \leq \Delta t^1, \quad (1)$$

where  $\Delta t = 20 \times 10^{-9}$  sec is the time between the activated and inactivated forms of the photosystems PII and PI [9];  $\Delta t^1$  - the time of passage of electrons from the photosystem PII to PQ and is equal to  $2.0 \times 10^{-6}$  sec [9].

The inequation (1) allows defining a root-mean-square time interval

$$\Delta t_k'' = \left\{ \left( \frac{2 \times 10^{-6} c}{20 \times 10^{-9} c} \right)^2 \right\}^{1/2} = 0,1 \times 10^3 \quad (2)$$

within which the relation between the energy of the system of the breakdown  $\delta\gamma_{II}$  into an electron-positron pair and the time  $\Delta t$  remains constant (3)

$$\Delta E \times \Delta t = \frac{\Delta E'}{\Delta t_k''}, \quad (3)$$

where  $\Delta E' = 0,497 \times 10^{-18} \text{ J}$  is the energy of almost all vitally important molecules, which biological structures consist of [10].

From the equation of the determination principle (3) the value of  $\Delta E$  within the interval  $\Delta t_k''$  is close to the kinetic energy of the electron

$$\Delta E = 0,2475 \times 10^{-12} \text{ J} \quad (4)$$

From the equation  $\Delta E = mc^2$  we have the value in mass units  $0,0275 \times 10^{-25} \text{ g}$  that is three times as much as an electron mass ( $0,91083 \times 10^{-27} \text{ g}$ ).

By extrapolation on activating the mechanisms of both the first and the second photosynthesis stages we protract the concept

$$\delta\gamma_{II} = 0,826e^- + 2,174e^+ \leq 150\text{ev} \quad (5)$$

It is known [14] that the formation of an electron-positron pair is possible if the kinetic energy of the electron exceeds  $10^6 \text{ ev}$ . However, its formation energy according (5) doesn't exceed  $150 \text{ ev}$  (0,015%), that coincides with the green plants absorption photoenergy in standard conditions for one mole glucose synthesis within

verging toward light speed, that is typical of electron tunneling in chemical and biological systems [11-13]

that at the light quantum "emission" from the activated photosystem P680\* to pheophetin and further on to PQ a breakdown  $\delta\gamma_{II}$  into an electron-positron pair which exceeds an electron mass threefold, not four times, according to the law of charge parity nonconversion (5).

the limits up to  $14460 \text{ kJ/mol}$  ( $150 \text{ ev}$ ) – depending on the absorption wave-length [8].

**II. The activation mechanism substantiation of both the first and the second photosynthesis stages.**

The standard available energy ( $\Delta G^{01}$ ) of an electron stream in the electron transfer chain from NADPH+H to  $O_2$ , which represents an exergonic process, is equal [8]:



In this case for dissolution of two moles of water under the influence of a positronium-ion ( $2,174e^+$ ) from (5) up to  $4e^-$  into molecules  $O_2$

it will be required  $440,16 \text{ kJ/mol}$ , that is  $38,4 \text{ kJ}$  lower than the reaction energy (7)

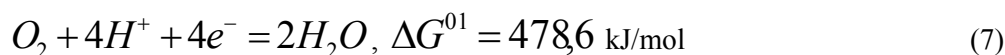

calculated from the equation (8)

$$\Delta G^{01} = -nFE_{298}^0 \quad (8),$$

where  $n$  is the number of the carried over electrons;  $F$ - Faraday number and  $E_{298}^0$  - standard electron potential equal to 1,24v.

The remainder of two water moles (from (6) and (7)) synthesis energy equal to 38,44 kJ is an energy measure of charge parity failure at the

breakdown  $4\gamma_{II}$  on pheophetin. Then, at the breakdown  $8\gamma_{II}$  this amount will make

$$8\gamma_{II} \approx 154 \text{ kJ/mol} \quad (9).$$

actually, we experimentally affirmed [5, 6] the dependency of four-cycle series of conversion photon flashout from a singlet  $^1\Sigma_g^+$ -state of oxygen  $2,174e^+$

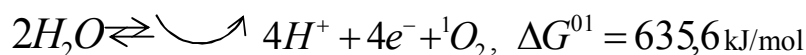

into a triplet one with a standard emanation energy 154 kJ/mol

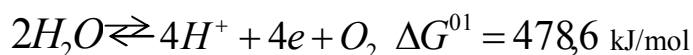

that is practically coincides with literature data (157 кДж) [8]. If it is remembered that the flush from  $8\gamma_{II}$  makes 1594,1 kJ, the total photosynthesis effectiveness in standard conditions makes 478,6/1594,1 as a minimum, or about 30%, that is also coincides with the literature data [8].

Glucose in plants is synthesized in the dark phase and is a predecessor of the three typical vegetational carbohydrates – saccharose, starch and cellulose, which are not synthesized in an animal body. In  $C_3$ -plants for photosynthesis of dextrogyrate D-(+) –glucose from the equation (7) for 6 moles of  $O_2$  it is necessary

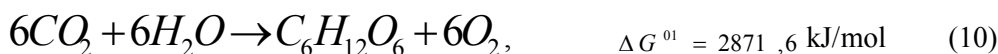

that is practically also comparable with the experimental value

$$\Delta G^{01} = 2870,2 \text{ kJ/mol} [8].$$

### III. $CO_2$ assimilation competition in $C_3$ - and $C_4$ - plants with $S_1 \rightsquigarrow T_1$ transitions

The breakdown of ribulose-1,5-diphosphate up to two molecules of 3-phosphoglycerate (A and B) under the action of ribulosediphosphate- carboxylase and the synthesis of D- (+) –glucose and its five

derivatives in  $C_3$ -plants (11) is attended in the dark phase of Calvin cycle. However, this complex process is geometrically close to the spherical electron-positive center of the photosystem PII (Figure 1). Which objective results could serve as the confirmation of this concept?

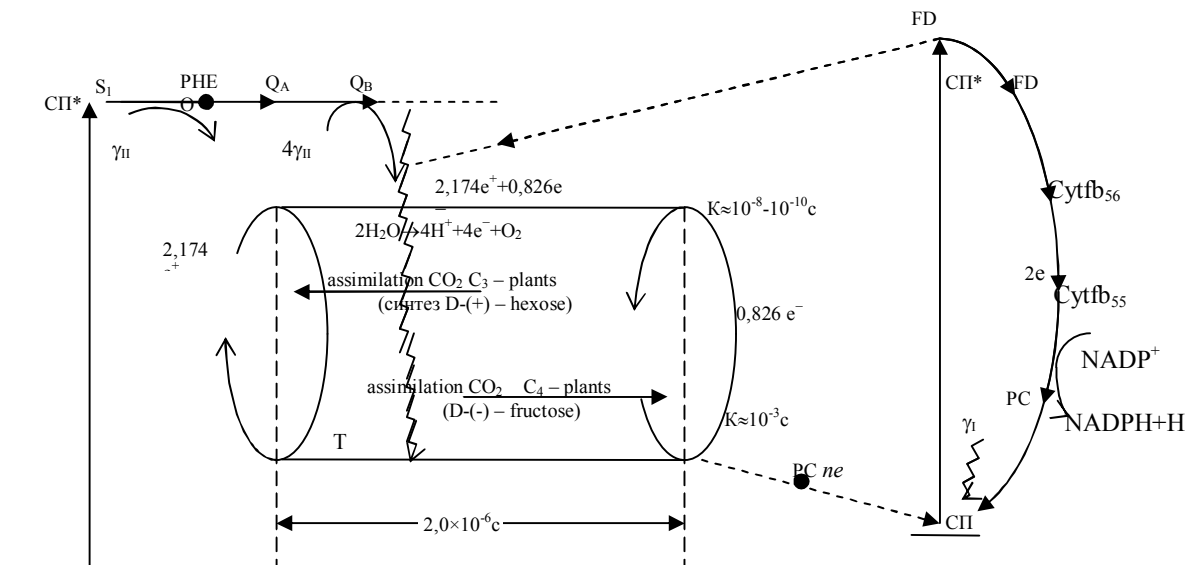

**Figure 1.** electron flow diagram in the model of two photosystems PII and PI: LP - light-harvesting pigments; PHEO – pheophetin;  $Q_A$  – primary plastochinon;  $Q_B$  – secondary plastochinon;  $S_0$  – the system energy in its main state;  $S_1$  – singlet low energy;  $S_1 \rightsquigarrow T_1$  - transition from a singlet into a triplet state; PC – plastocyanin; FD – ferredoxins (hinded) and FD – soluble ferredoxins

First, the transient composed by carboxy group joining to ribulose-1,5-diphosphate corresponds to ( $10^{-7} - 10^{-10}$  sec) lowest singlet state ( $S_1$ ) by life time. The molecule in the lowest singlet state is very quickly hydrolyzed with formation of two molecules of 3-phosphoglycerate, one of which – glycerate A, contains the mark  $^{14}CO_2$  in the form of carboxy group [8, 15].

Second, the singlet-excited transition molecule (11) suffers an intercombination conversion in the form of hydrolyse up to two glycerate molecules, that is attended by the transition into a more stable state ( $T_1$ ). The life time of the lowest  $T_1$ -state is rather long to form D-(+)-glucose from two glycerate A molecules. In another situation the interaction of glycerates A and B would lead to levogyrate D – (-) - glucose formation, that according to

stereoselectivity is unauthorized close to the electron-positive center of PII (Figure 1).

And third, one of structure fragments of many oligosaccharides (for example, saccharose and raffinose), polysaccharides (for example, innulin) is D – (-) -fructose. In temperate zone plants but which hail from the tropics (corn, sugar cane or amercane) the  $CO_2$  assimilation happens in the way of  $C_4$ -metabolism (Hatch-Slack reaction). The  $C_4$ -plants include  $CO_2$  into a  $C_4$ -compound and only after two preliminary migration stages fix  $CO_2$  the same way that the  $C_3$ -plants do. This assimilation way leads to a sufficient removal from the center PII in the cycle of Calvin, and thus, a long enough time (about  $10^{-3}$  sec) is needed for the synthesis of D – (-) -fructose (Figure. 1).

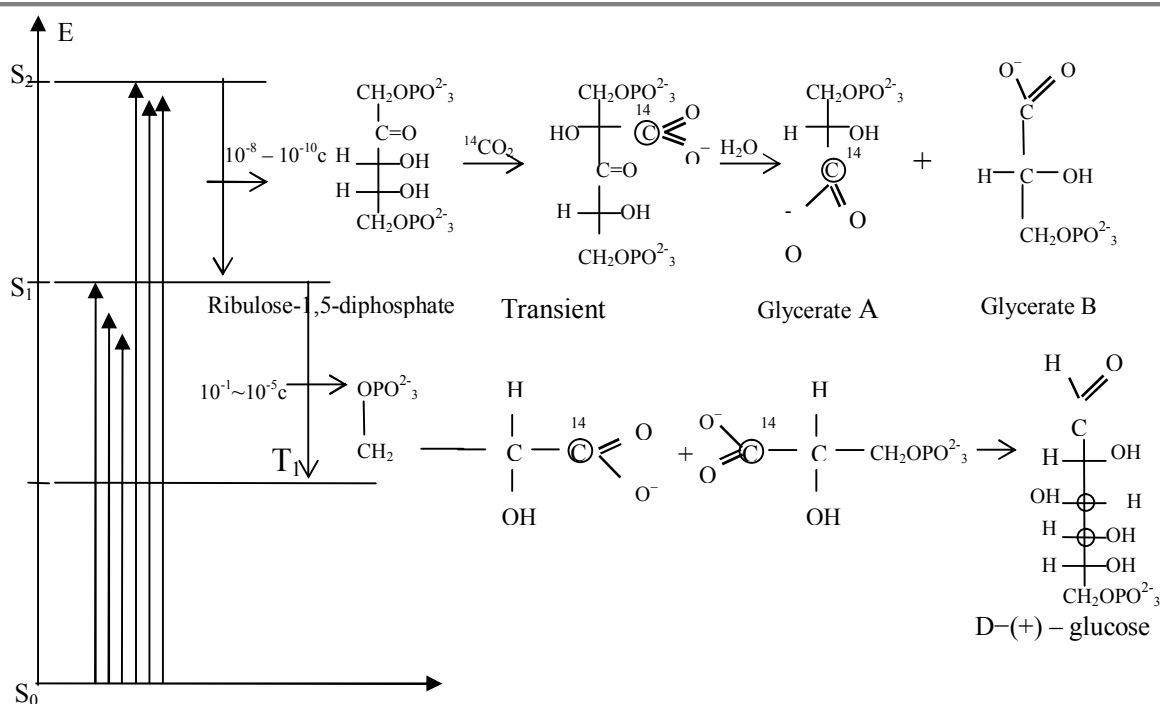

Hence, physical processes conditioned by the intersystem crossing – the transition between the two electron states of equal spin multiplicities  $S_1 \rightsquigarrow T_1$  compete with chemical reactions of CO<sub>2</sub> assimilation in C<sub>3</sub>- and C<sub>4</sub>-plants.

#### References:

1. Pions. Elementary particles. M.: Mir/World, 1963, 322-39
2. Heisenberg W. Z. Phys. 1927; 4; 172 –
3. Powell S., Fauler P., Perkins D. Elementary particles study by means of photography method. M.: Mir/World, 1962.
4. Lokhov R.Ye. The certainty principle in chemical transformations/ European J. Natural history.2006; №5: 93-96.
5. Lokhov. R.Ye., Bioenergetic systems: a new look at the functioning and stimulation mechanisms. European J. Natural History.2006; 6: 68-73
6. Lokhov R.Ye., Lokhova S.S Photosintesis: New concept of the socavenergy functioning and transformation. European J.Natuvae histry.2006; # 6:74-76
7. Photosynthesis and the Enviroment. Kluver Academic Publishers,Pordrecht, Netherlands,1996.

8. Stryer L. Biochemestry.4-th Ed. W.H.Freeman and Company, New York 1995.

9. Nicholls P.G.Bioenergetics an introduction to the chemiosmotic theory. Academic Press, London, New York, 1982.

10.Dovgusha V.V.,Sledkov A.Y. Basing biophysical mechanisms of xenon narcosis. Scientific-practical conference 'Xenon and xenon-saving technologies in medicine-2005'.Collected articles.Moscow,2005;29-43

11.Göldansky V.J., Caplan A. M. Tunneling electrons. Science and Mankid journal. Znanie, Moscow,1988.

12.Moelwyn-Hughes E. A. The Chemical static's and kinetics of Solutions. Academic press, London-New York, 1971

13.Alberts B.,Bray D., Lewis J., Raff, Roberts k., Watson J. Molecular Biology of the Cell. Garland Publishing,Inc. New Yorc-1983

14.Pauling L., Pauling P. Chemistry. W. H. Freenan and Company. San Francisco,1975

15.Einführung in die Photochemie. Voneinem autorenkollektiv. VEB peutscher Verlag Wissenschaften, Berlin, 1976.

## Materials of the Conferences

### THE DYNAMICS OF CLINICAL HEALTH OF THE COHORT GROUP EXPOSED TO CHLORANATED DOSES OF TCDD

Basharova GR, Karamova LM\*  
*Bashkir State Medical University, Ufa, Russia*

*\*Ufa Institute of Occupational Health and Human Ecology, Ufa, Russia*

**Abstract:** The data on the dynamic clinical 40-year observation of health promotion of workers with chloracne who were involved in the production of 2,4,5 T are presented in the paper. The clinical picture of intoxication was characterized by moderate cytopenia, hypercholesterinemia, vegeto-vascular dystonia with background chloracne signs. Postcontact follow-up data on a closed cohort aged 23-63 years showed the disappearance of chloracne manifestations, but there were signs of pigmentation, proliferative formations. Monolymphocytosis was found in blood samples. There is evidence of an increase in the number of lipids, enzyme activity, blood coagulation, biological age. Functional disorders of the neuro-vegetative and cardio-vascular systems are transformed into clinically marked destructive diseases such as IHD, infarcts, insults, tumours that shorten the life span.

**Introduction:** During the past decades, studies involving experimental, environmental and epidemiological surveys of many scientists as well as our own data on clinico-functional manifestations and medico-biological consequences of dioxins have shown these supertoxicants to be hazardous in their impact on health of exposed individuals and their offspring. The toxic substances originate the development of numerous geno-, phono- and locally specific effects.

Most investigators (1-4) believe that due to their cumulative characteristics dioxins produce a long term hormone-like impact on the development and functioning of the body systems. Even though the contact has ceased, the formation of a broad spectrum of clinically manifested and subclinically multilevel health disorders is in progress.

**Materials and Methods:** Enrolled in our study is a group of individuals who were involved in the production of 2, 4, 5 T between 1965 and 1967. All 128 workers developed chloracne. We have been following these occupationally exposed subjects with chloracne manifestations since 1990.

**Results and Discussion:** Retrospective analysis showed the absence of dioxin content measurements during technological processes of 2, 4, 5 T production. According to calculations by L.A. Fedorov (1993), dioxin content in the end product was no less than 30-40 mg/kg (5). The singular clinically-based medical examination revealed chloracne in 85,3 % of workers. Long term treatment resulted in the disappearance of this disease signs. So, the first complex clinico-functional examination of exposed workers was conducted with background chloracne clinical signs.

The majority of male patients were at the age of 20-26 years. The mean age of the whole cohort was  $23 \pm 2,5$  years. The examination detected typical chloracne in all of them. Moderate neutropenia, lympho and monocytopenia were found in peripheral blood of 32-37,7 % of workers. Hypercholesterinemia was detected in 43,8 %. Every other subject ( $46,0 \pm 4,3$ ) had vegeto-vascular disorders of sympathico-adrenal origin. Clinically marked diagnoses are mainly associated with vegeto-vascular dystonia, chronic gastritis, cholecystitis, bronchitis.

The subjects whose mean age was 38 years were re-examined in 1984/1985. There was no evidence of chloracne. However, numerous pigment spots of various intensity, hyperkeratic and papilo-like formations were found on their back and hips. The number of cardiovascular pathology cases with clinical formation of hypertensive and ischemic diseases increased significantly. Two cases of myocardial infarction and diabetes mellitus were detected. The blood sample was characterized by a moderate elevation of white blood cells. The level of activity of enzymes, autoimmune processes tended to be high. There was a distinct trend towards immunity suppress.

Ten years later, between 1990 and 1995, further investigations were carried out. Alongside with the studies conducted between 1996 and 2006, they confirmed an elevation in the incidence of atherogenic pathologies including lipidemia, enzymopathy, hypercoagulation, atherosclerotic processes in the

brain and heart vessels. Every fourth individual aged 46-53 years was found to have CBS, myocardial infarction and brain insult. The increased rate of cancer was observed. There was evidence of an increase in diseases in every subject.

**Table 1.** Presented is the dynamics of the cohort clinical health (in %)

Years	1966-67	1984-85	1990-95	2004-2006
Age	20-26(M=23±2,5)	38-43(M=38±3,3)	47-53(M=51±1,4)	63-70(M=63±2,5)
Clinical signs				
Cardiovascular: ECG- Arterial Hypertension	52,6±3,4 AH-40,0(20)	78,8±7,1 58,8(15,4)	100,1±0,5 56,5(31,3)	100,0±0,3 40(82,2)
Cerebral circulation disorders Ischemic heart disease	-	IHD - 13,0	IHD - 25,4 MI, CCD	CCD, IHD, MI
CNS: VVD NCD	46,3±4,3 16,6±2,0	56,0±5,6 encephalopathy	NCD encephalopathy	NCD encephalopathy
Respiration: Ch. bronchitis	5,4±1,1	8,3±1,2	12,5±1,6	19,2±2,1
Alimentary tract: ch.gastritis ch.cholecystitis	21±2,4 14,4±4,1	36,6±6,0 16,8±4,0	38,7±4,5 16,7±2,3	37,2±2,4 19,1±2,8
Skin:chloracne, eczema, dermatitis	100,0 6,0	2,0 7,0	- 3,0	- 2,6
Endocrinology: diabetes, thyroid gland	- 1 case	2 cases 2 cases	2 cases 2 cases	2 cases 2 cases
Others: dental cancer	- -	38,4 1,4	88, 4,7	100,0 19,2
Blood: leukocytes eosinophils lymphocytes monocytes hypercoagulation	reduced 19,5 higher 28,9 lower 37,7 lower 32,1 no evidence	increased 11,0 higher 18,1 higher 11,0 higher 25,0 42,7±1,7	Normal normal higher 18,6 higher 33,8 53,4±3,7	Normal normal higher 20,0 higher 35,7 83,4±4,3
Biochemistry  Glucose Cholesterin β Lipoprotein BLOI Mean molecule	No evidence No evidence Normal 43,8 no evidence no evidence no evidence	increased 18,7 increased 14,4 normal no evidence no evidence no evidence no evidence	increased 25,7 increased 18,9 increased 10,0 increased 49,6 increased 10,2 reduced -14,0 increased 77,4	increased 22,3 increased 24,4 increased 12,6 increased 56,6 increased 18,8 reduced 21,2 increased 81,25
Immunol.lymph. B lymph. Olyph. Im.A CIC	No evidence No evidence No evidence No evidence No evidence	Reduced 50,0 Reduced 51,0 Increased 60,0 increased 13 increased 12 increased 14,0	reduced 64,3 reduced 34,3 increased 51,4 increased 17,4 increased 16,4 increased 17,0	reduced 77,0 reduced 34,6 no evidence increased 20,0 increased 22,8 increased 19,5
Number of diseases per person	1,0	1,4	3,7	8,0

Now that the mean age of the cohort studied is 63 (from 63 to 70 years), it is obvious that marked atherogenic processes and disorders

have increased with age. However, comparative health studies of the cohort and controls matched in age show the rate of disorders in subjects



exposed to dioxins to be significantly elevated over controls.

Special calculations of the cohort biological age showed that individuals with a history of chloracne were 18-20 years older than their calendar age. There was a 1,5 fold rise in mortality rate compared with the general city population. The mean age of dead people was  $52,3 \pm 4,3$  years.

Thus, the dynamic health follow-up of workers exposed to dioxins in the cohort group aged 23 – 63 years has shown that skin disorders like chloracne disappear but pigmentation and proliferative processes occur. Cytopenic reaction is associated with a trend toward a decrease and replacement by mono- and lymphocytosis. Levels of lipids, enzyme activity, blood coagulability, and biological age increase gradually. Functional disorders of the neuro-vegetative and cardiovascular systems are gradually transformed into clinically marked destructive diseases such as IHD, infarcts, insults, tumours that shorten the life span.

#### References:

1. Roumak V.S., Poznyakov S.P., Umnova N.V. The baseline of biological assessment of dioxin hazards // Dioxins are supertoxicants of the XXI century. Medico-biological problems. – M., 1998, P. 111 p.
2. Poznyakov S.P., Roumak V.S., Umnova N.V. 2,3,7,8,- tetrachlorbenzo-p-dioxin – hormone-like deazantogenic supercotoxicant // Jour. of Ecol. Chemistry – 1993. N 3. P. 189-212.
3. Roumak V.S. Medico-biological assessment bases for remote consequences of phytotoxicants containing 2,3,7,8 T used in military purposes (Agent Orange in Ranch Hand as an example) // Doctorate thesis. St. Petersburg, 1993. – 50 p.
4. Basharova G.R. Medico-biological dioxin consequences // Candidate thesis. 1996. 20 p.
5. Fedorov L.A. Dioxins as ecological danger: retrospectives and perspectives // edit. by V.V. Onaprienko/ - M., Science, 1993. – 265 p.

---

The article is admitted to the International Scientific Conference “Prospects of development of a high school science”, Sochi (Dagomys), September, 20-23th 2007, came to the editorial office on 14.06.07

#### EDUCATION IN OPEN SOCIETY: PROBLEMS OF VARIABILITY

Dudina M.N.

*Ural State University named after Gorky A.M.  
Yekaterinburg, Russia*

Large-scale sociocultural transformations of the 90-s of the XX century brought our country to the state of openness, defined the way to develop an open society. The law of the RF “On education” opened unseen until then opportunities for educational institutions’ types and kinds diversity growth, educational programs variability, their development terms, forms and methods of teaching, using innovation technologies including control-valuation activities, alternativeness of learners’ accountancy forms. Delimitation of authorities and competences between state and private educational institutions, federal, regional and municipal authorities promoted educational democratization. More than that, not only the teacher and the pupil, the lecturer and the student were named the subjects of education; directly or indirectly parents, community and business leaders, employers turned the ones. The “Educational loan” became brand-new and promising opening real ways to get education for an ample quantity of the desirous.

Lively started deregulation of education has been intensifying since January, 2005, opening a prospect to state educational institutions’ share reduction; that, however, doesn’t mean a “withdrawal” of the state from the educational system. Its attendance is carried out in a variety of ways, among which the availability of national educational standards (unfortunately, being for long in the state of projects). On the one hand, they go on performing regulating function (if not a dictate concerning the “liability” of subject fields, specialties, duration and extent of discipline studies and their contents); on the other hand, - protective function – from arbitrary actions in education (including its contents and efficiency criteria of educational process).

*A standard* (Eng. norm, pattern, measure, foundation) as a notion is connected with achieving certain norms of quality reduced to typical markers. Let us focus our attention on interpretation of the notion “standard” as a *measure of quality, foundation of quality*, that

goes into contradiction with a very popular idea of a standard as a minimum, also in getting skills.

*Variability* - (Lat. *varians*, *variantis* – changing) modification, diversity, - supposes a breakaway from the nominal principle and, with it, dictates widening the cognitive space, opening the opportunity of mastering other knowledge and skills. The idea of standard (invariant) and variability became of current interest, first of all, because in Soviet education there was no idea of variability at all, but especially – in connection with entering the European educational space, inspired by life in the open society and priorities of national strategy of stable development, by Russia. Now it is certainly possible to bespeak that the education in present-day Russia, in spite of crisis processes and considerable difficulties of their negotiation, is developing even at a faster rate, having many positive results, however, not nearly always measured and measurable in accord with the criteria of quality connected with the idea of standards and variability in the context of the new educational paradigm.

*A paradigm* (Gr. *paradeigma* – sample, model) is a notion comparatively recently come into the scholarly apparatus of pedagogy, became widely used and connected with integral ideas of methodological, theoretical and axiological principles adopted by present-day academic community as a pattern for solving theoretical and practical problems. The paradigm approach in pedagogy is productive in scientific search of theoretical-methodological foundations and practice of humanistic orientation, the process of its conceptual-categorical apparatus' renewal being connected with it. So the problem area, conditioned with the necessity and possibility to find a position in standards and variability of education actualizing such notions as personal development training, multilevel education, productivity and destructivity of educational process, full (and flawed) academic activity, pedagogical support, accompaniment, freedomability and freedom advisability in education, subtraction from education, was opened. These and linked with them notions and categories enrich modern education proceeding from the methodological principles of the new paradigm, the aim and result and also one of the instrumental quality criteria of which is *human dimension*. It is this criterion, which has put questions of the educational values and purposes revising necessity. To answer the question – Why

is it to teach? – it is necessary to take into account not only the society and personality wants, but also cultural possibilities associated with the needs of its further development. These three matrixes in the development of educational perspective development strategy (anthropological, social and cultural, according to Belyayeva L.A., 1, p. 13), are of current interest with a view to life globalization and integration processes of Russia's entering the world's educational space, that demanded putting the educational system in accordance with the global standards.

The divergences of home educational system and European one turned out to be quite considerable from methodological, theoretical and especially technological positions. Nowadays the question is about the development of *lifelong education*, *permanent education*, 12-years school, *multilevel higher* (of the three levels - undergraduate, graduate, postgraduate) education, about using the variety of teaching forms, about widening of specialties' number, use of credit, accumulative point rating knowledge evaluation system, about a notable increase of students' and school children's solitary work share, carrying out social and practice oriented projects ("everything from and for life"), and, finally, about the right of learners to choose their teachers. Everything is aimed at the ambition to make education mobile, and the graduate – competitive on the labour market.

And if Russia's entering the Bologna process puts many questions in front of the domestic educational system, and some of them are being solved already, the problems of national identity and Russian traditions preservation, and more than that, the ones of enriching the world's educational space with the best things that represent our national pride (4,5) seem to be not less significant. In our point of view, these are the ideas of Russian cosmism and noospheric education which are developed by native philosophers, naturalists and culturologists, and which, however, are to be developed by Russian education of the new century as well.

*Cosmism* as a belief about the world and its integrity and as a doctrine of cosmic expansion of the mankind - an original trend of domestic thought from the middle of the XIX century – was a breakthrough in social human reflection, for European thought of that time held to

anthropocentric picture of the world outlook, according to which the human was recognized as Lord of Creation. The three directions of Russian cosmism, according to Yemelyanov B.V. (3), comprehend philosophy, science and culturology. Penetrated with the idea of anthropocosmism, they can be worthily represented in the universal educational space of an open society. In the upbringing of a modern individuality the cosmic world outlook, which includes the recognition of the human as a component of Space, its rational reflecting component, is important. To understand the fact that the human being as homo sapiens became real in the process of long historical development of living matter, one of the potent consciously acting factors of further nature evolution, - it means to understand his role, mission and to understand himself on this Earth, his destination. The thinking, creating human being is a co-author, a "direct participant of cosmic scale and value processes".

That is why a particular interest and place in modern education by right can and must be occupied by the Russian philosophy, having included the ideas of collegiality and unity of Solovyov V.S., Fyodorov N.F., Florensky P.A., Bulgakov S.N., Berdyayev N.A. And also the carrier of its ideas – the Russian literature, having defined the understanding of the human spirit wholeness, sentience, the accord of perception and morality mastering. This is "living knowledge" through attainment of Truth, Good-natured and Beauty in Tolstoy's, Dostoyevsky's, Chekhov's, Bulgakov's prose; Pushkin's, Lermontov's, Bryusov's, Balmont's, Severyanin's, Khlebnikov's, Zabolotsky's, Pasternak's, Tsvetayeva's, Akhmatova's poetry. This is also cosmic fantasies of Chaikovsky's, Skryabin's, Rakhmaninov's. Shnitke's music; Vrubel's, Nesterov's, Rerikh's painting.

Human day-dreams about the Earth and the Heaven were common also among scientists developing cosmic world outlook and noospheric thinking. The scientific direction considers a human being as a part of the environment and significance of his activity after-effect in it. The idea: the world as a wholeness – lead to the study of anti-entropic activity of the mankind, its possibilities to regulate the cosmic chaos, hence the confidence that "the mankind will not stay on the Earth forever" (Tsiolkovsky K.E., 1911). Vernadsky V.I. developed the idea of a particular significance of human vital activity for the

biosphere and with it - for the Space. His main idea is about responsibility of the mankind for everything happening and taking place on the Earth and in Space. Long before understanding the idea of Unity by the world's community and educational system Chizhevsky A.L. wrote about Space as about a common home, where "common blood is flowing in veins of the whole Universe".

The worth of Russian cosmists' idea is in the heuristic idea of the necessity for the people to unite, to overcome created by the civilization barriers between the subject and the object, natural and artificial one. In the face of Space the mankind appears as integral, organic whole, directed into Eternity. Having realized the connection with Space, the mankind must have healthy moral attitude to it.

Such a "discovery" must and can take place not only in Russian, but also in the world's educational space on the way of attainment of the backbone culture of an individual. In the educational process of a school, college and higher educational institution (in the standard or variability) there is a great opportunity to extent space and time to percept the world and the human in it through addressing to the history of scientific thought, "eternal questions" solution traditions connected with the human and his existence. The ideas of Russian cosmism will help answer the question: "What to teach?" in the new way, i.e. about the substantial component of the standard and variability of education. That is the addressing to the fundamental notions of cosmism – *active evolution, co-evolution, noosphere, anthropocosmism, Unity of noospheric thinking, ecological imperative, cosmic feeling, pantheism, noospheric ethics*. Present-day world's educational space can worthily value the methodological, world outlook, axiological, ethic, culturological and pedagogical worth of these ideas as basic ones in the universal educational environment. The acquirement of noospheric educational conceptual-categorical apparatus, *noospheric ethics* will allow implementing the advanced function of pedagogy on the ways of humanitarization of education, enriching natural science knowledge with irrational support and humanitarian knowledge – with rational one; dialogue of cultures, civilizations and ideologies. It is real in the one national educational space through realization of standards and variability;

in the space which inevitably will call for the Russian language as existential foundation of Russian culture in the capacity of the world's one as well.

In such understanding of the essence and destination of the national educational space and the role of the Bologna process, undoubtedly, possessing heuristic sense, Russia can productively use foreign experience and enrich it with fundamental ideas of native idea. Russian culture is able to enrich the world's educational space of an open society including the ideas of cosmic pedagogy, which is knocking at doors, our native educator Ventsel N.K. wrote and called us up to "open them wide and study it seriously".

#### References:

1. Belyayeva L.A. Pedagogical in the context of modern educational philosophy/ Education in the Ural Region: Scientific foundations of innovation development/ Thesis of III Regional scientific-based training conference reports, 11-15 April, 2005, Yekaterinburg, pp. 13-15.
2. Dudina M.N. Philosophic propaedeutics. Or: All ages are submissive to philosophy. Yekaterinburg, 2000.
3. Yemelyanov B.V. Sketches on Russian Philosophy. Yekaterinburg, 1995.
4. Ivanova V.I. Bologna process and Russian Higher education// Pedagogika, 2006, №1.
5. Lurye L.I. Lurye M.L. Bologna process and new constructs of pedagogical culture. Actual problems of modern professional education. Materials of the conference held in the frame of the International congress "V Slavonic educational readings" 1-2 November, 2006. M., Pedagogika, 2006.
6. Naumov N.D. Russian pedagogy in XX century: main directions and philosophical foundations. Yekaterinburg, 2003.

---

The article is admitted to the International Scientific Conference "Problems of the international integration of national educational standards", Paris-London, April, 20-27th 2007, came to the editorial office on 20.02.07

### COMPARATIVE CHARACTERISTICS OF HEALTH STATUS OF PARENTS EXPOSED TO CHLORENATED DOSES OF TCDD AND OF THEIR CHILDREN

Karamova L.M., Basharova G.\*

Pyanova F.Z.

*Ufa Institute of Occupational Health and Human Ecology, Ufa, Russia*

*\*Bashkir State Medical University. Ufa, Russia*

**Abstract:** The comparative health studies of subjects exposed to dioxin and their children have shown that functional changes in the cardiovascular system, arterial hypertension, gastritis occurring in adults do not differ significantly from the same disorders when seen in the pediatric age group. There is evidence that at a later age the children may develop the diseases similar to those of their parents – ischemic heart diseases, hypertension, insults, cancer.

**Introduction:** Dioxins are known to have a high level of cumulative activity. Because of this they are hazardous not only during contact period. Negative processes in all bodily organs and functional systems occur within the lifetime.

Most scientists believe that the presence of dioxins inside the parental body has large effects on health of the offspring. The most convincing studies were conducted in Yusho and Yu-Cheng (1-5). The effects of accidentally consumed rice oil contaminated with TCDD on the regional population health were related to reduced birth weight, height, skin hyperpigmentation, retarded growth and psychoemotional development, impaired memory, hypoplasticity, abnormal finger and toenails. In Yusho, children born to mothers exposed to dioxin, died from cardiovascular pathology. However, the authors themselves consider the results obtained to be associated with a variety of factors. In rice oil TCDD was not found alone, it contained a mixture of different chemicals.

**Materials and Methods:** We have been following a closed cohort of subjects exposed to TCDD during the manufacture of 2,4,5 T between 1965 and 1967. The mean age of the subjects when they developed chloracne was 23±2,3 years. During contact period and after it, 103 children were born to the families exposed to dioxin. During a recent four year period, 2004 - 2006, a complex pediatric health study including questionnaire on working and living conditions,

quality of life, health self-assessment was conducted. The individuals who wished to be studied by physicians were offered a complex clinico-functional examination. Thirty subjects

were clinically examined by various hematological, biochemical, immunological professionals.

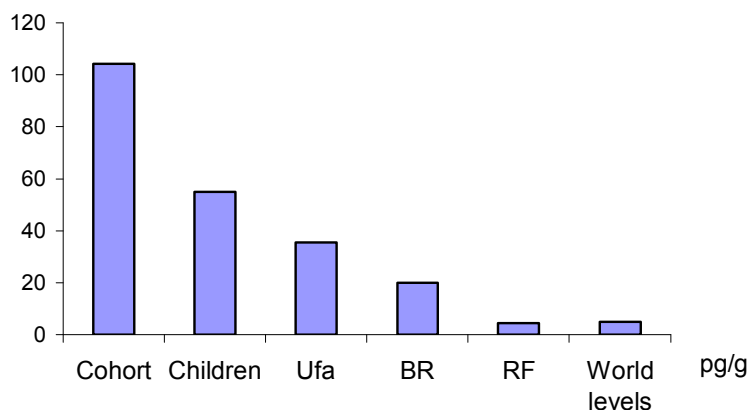

**Figure 1.** Dioxin content in subjects exposed by chlorinated doses of TCDD, in their children and population

**Results and Discussion:** All the children of the cohort are at the age of 24-39 years. Of importance is the fact that there is a 1,2-fold elevation in the number of female children compared with male children. Among subjects aged 35-39 years who were born during contact and early post-contact period this disbalance is 2,0 (66% of females, 34% of males). Gender disproportion of newborn babies was determined in our previous studies (1990-1995).

According to the Republican Centre for Ecology (6), parental TCDD mean concentration is currently determined to be 104,2 pg per gram of blood lipid.

TCDD concentration from 31 to 80 pg per gram of blood lipid is found in the body of the children, confirming the hereditary fact. The mean level of dioxin in the pediatric group is 55 pg per gram of blood lipid that is 2 times greater than the background index of the Russian Federation population (6) (fig. 1).

By the time of Stage I study (1990-1995), the children born with background chloracne during post-contact period reached the age of 15-26 years. The mean age was  $20 \pm 2,2$  years. Only every other person among them was regarded to be healthy. (Table 1)

**Table 1.** Illustrates characteristics of the cohort children's health (%)

Signs	1st child	2-nd child	3-d child	4-th child	All children
Healthy	36,6	55,6	70,0	100,0	51,7
Sick, including	63,4	44,4	5,0	-	48,3
Allergy	7,0	6,7	10,0	-	7,9
Chronic bronchitis	4,2	6,7	-	-	5,3
Arterial hypertension	1,4	4,4	-	-	0,8
Gastritis, ulcer	7,0	6,7	-	-	7,0
Cholecystitis	1,4	-	-	-	0,8
Endocrine disorders	2,8	-	-	-	1,7
Other disorders	41,0	20,0	20,0	-	25,8
Mean number of disorders per patient	1,5	1,0	1,0	-	1,2

Clinico-functional health levels of children who underwent clinically-based examination were compared with analogous levels of their parents who had a history of dioxin exposure with marked chloracne. Previous diagnoses of

parents aged 26-35 years were observed. We report here the recent diagnoses (1995-2000) with parental age to be over 60 years. Some of them died. (Table 2)

**Table 2.** Comparison of diagnoses of children and their parents exposed to TCDD chlorinated doses

Parental diagnoses		Pediatric diagnoses
Studies between 1968-1980		Studies between 2004-2006
1.	Hypertension. Vegeto-vascular dystonia	Vegeto-vascular dystonia. Ch.gastritis
2.	Vegeto-vascular dystonia. Ch. gastritis	Vegeto-vascular dystonia. Ulcer
3.	Vegeto-vascular dystonia. Hypertension	Vegeto-vascular dystonia
4.	Vegeto-vascular dystonia. Ch. gastritis	Vegeto-vascular dystonia. Ch.gastritis
5.	Vegeto-vascular dystonia. Ch. Bronchitis	Vegeto-vascular dystonia
6.	Vegeto-vascular dystonia. Ch. bronchitis	Hypotheriosis. Hypophysial insufficiency. Myocarditis. Ch.bronchitis, cholecystitis.
7.	Vegeto-vascular dystonia.	Vegeto-vascular dystonia.
8.	Vegeto-vascular dystonia. Ulcer.	Vegeto-vascular dystonia. Hypertension
9.	Vegeto-vascular dystonia. Ch. gastritis	Vegeto-vascular dystonia. Ulcer
10.	Vegeto-vascular dystonia. Ch. Gastritis. Ch. cholecystitis	Vegeto-vascular dystonia. Ch.gastritis
11.	Vegeto-vascular dystonia. Ch. Gastritis.	Vegeto-vascular dystonia. Ch. Gastritis
12.	Vegeto-vascular dystonia	Vegeto-vascular dystonia. Ch.gastritis
13.	Vegeto-vascular dystonia. Ch. cholecystitis	Mitral valvular disease.
14.	Hypertension	Vegeto-vascular dystonia. Encephalopathy.
15.	Vegeto-vascular dystonia. Arterial hypertension.	Vegeto-vascular dystonia. Ch.gastritis
16.	Vegeto-vascular dystonia. Ch. gastritis	Vegeto-vascular dystonia. Ch.gastritis

17.	Vegeto-vascular dystonia. Ch. Gastritis. Arterial hypertension.	Hypertension. Ch. gastritis	Vegeto-vascular dystonia. Ch.gastritis. Ch. cholecystitis.
18.	Vegeto-vascular dystonia. Arterial hypertension.	Ischemic heart disease. Hypertension. Myocardial infarction	Erythema nodosum. Ulcer. Arterial hypertension
19.	Vegeto-vascular dystonia. Arterial hypertension.	Vegeto-vascular dystonia. Hypertension. Ch.gastritis	Vegeto-vascular dystonia. Ch.gastritis
20.	Vegeto-vascular dystonia. Ch. Gastritis. Arterial hypertension.	Vegeto-vascular dystonia. Ch. bronchitis	Vegeto-vascular dystonia.Ch.bronchitis Arterial hypertension
21.	Hypertension. Ch. gastritis.	Ischemic heart disease.Hypertension. Ch. gastritis.	Vegeto-vascular dystonia. Ch.gastritis Arterial hypertension
22.	Hypertension. Ch. gastritis. Arterial hypertension.	Hypertension. Ch. gastritis. Ch. cholecystitis	Vegeto-vascular dystonia. Ulcer. Arterial hypertension
23.	Vegeto-vascular dystonia. Arterial hypertension. Ch. pyelonephritis	Ischemic heart disease. Hypertension.	Vegeto-vascular dystonia.Ch.bronchitis Arterial hypertension
24.	Vegeto-vascular dystonia. Arterial hypertension.	Ischemic heart disease. Hypertension. Ch. gastritis.	Vegeto-vascular dystonia. Ch.gastritis Arterial hypertension
25.	Vegeto-vascular dystonia. Arterial hypertension.	Ischemic heart disease. Hypertension. Myocardial infarction	Vegeto-vascular dystonia. Arterial hypertension.
26.	Vegeto-vascular dystonia. Arterial hypertension. Ch.gastritis	Ischemic heart disease. Hypertension. Ch. gastritis.	Polyvalent allergy
27.	Vegeto-vascular dystonia. Arterial hypertension.	Ischemic heart disease. Hypertension. Myocardial infarction	Vegeto-vascular dystonia. Ch. Gastritis
28.	Vegeto-vascular dystonia. Arterial hypertension. Ch. gastritis.	Ischemic heart disease. Hypertension. Ch. gastritis.	Vegeto-vascular dystonia. Ch.gastritis. Ch. bronchitis
29.	Vegeto-vascular dystonia. . Arterial hypertension.Ch. gastritis.	Ischemic heart disease. Hypertension	Vegeto-vascular dystonia. Ch. Gastritis
30.	Vegeto-vascular dystonia Arteria Hypertension. Ch. gastritis	Hypertension. Ch. gastritis	Vegeto-vascular dystonia. Ch. Gastritis

Comparative analysis showed that parental diagnoses established in young life (matching in age with the children) were not different from pediatric ones. It is reasonable to suggest that in later life the children will develop the same diseases as their parents have.

Questionnaire information on health revealed that 51,1% of respondents considered themselves to be “practically healthy” and 48,9% were “sick”, respectively. The most common complaints were headache – 58,4%, dizziness – 42,2%, bitter taste in the mouth – 26,6%. Analysis of the answers to the question “What

troubles you?" revealed that 21,1% of subjects had cardio-vascular disease, 18,4% - the neuro-system disorders, 14,3% - digestive disorders, 11,9% - respiration disorders, 4,3% - endocrine disorders. Of importance is the fact that hypertensive disease, arterial hypertension, vegeto-vascular dystonia of hypertensive type, neuro-vascular dystonia constitute the group of cardio-vascular and nervous system diseases. It should be noted that the rate of cardio-vascular pathology accompanied by hypertension is about 3 times (2,8) higher among the children of the exposed parents than among the general adult population of the Republic of Bashkortostan. Our previous studies (7) showed cardio-vascular, atherogenic effects of dioxins on parents enrolled in our closed cohort we have been following since 1968.

Thus, our comparative studies have shown that the children of subjects who had chloracne have the same health disorders as their parents.

#### References:

1. Vysochin V.I. Dioxin and relative compounds Analytical review (USSR AS – Novosibirsk – 1989. 153 p.
2. Shecter A., Papke O., Lis A. Dioxin Dibenzofuran Elevation in Humans Following Exposure in Yusho // *Dioxin' 93*, Vol.13, P. 85-89.
3. Lai t., Guo Y.L., Chen S.J. Cognitive Development in Yucheng Children // *Dioxin' 94*. 1994. Vol. 1. P.513-517.
4. Larri L. Nidkhem. Historic studies of Yuchen accident // *Dioxin' 93*. Vol. 14. P. 231.
5. Westings A. Reproductive epidemiology // London Taylor Francis. 1999.
6. Amirova Z.K., Kruglov E.A. Dioxin situation in the Republic of Bashkortostan. – Ufa, 1998. 115 p.
7. Basharova G.R. Medico-biological consequences of dioxins. Ufa, 2002. 247 p.

---

The article is admitted to the International Scientific Conference "Prospects of development of a high school science", Sochi (Dagomys), September, 20-23th 2007, came to the editorial office on 14.06.07

## CREATIVENESS ("TVORCHESTVO") AND CREATIVITY: AN ANTHROPOLOGICAL THEORY

Petrova V.N., Petrov A.  
University RAE  
Moscow, Russia

As of today there is neither a theory of creativeness ("tvorchestvo") nor a united platform treating and defining the notion of the "creativity", "creativity" and "creative thinking". We have been developing an anthropological theory of creativity for seven years, and this is a qualitative research.

The basic developmental **principles** of this theory are: *non-contradiction, lack of theoretical foundation, practice-centered character; accumulation of sufficient quantity of unspecified ties; shifting over, integrity, formalized nature and interrelationships of all positions, critical attitude to other theories.*

The basic **notions** of the anthropological theory of creativity are:

*Creativeness* ("tvorchestvo") – this is a goal-oriented processing of information while the memory of attention is inactive.

*Thinking* – this is a goal-oriented processing of verbal information while the memory of attention is active.

*Creativity* – which is a goal-oriented processing of verbal information with active memory of attention; formation of creativity patterns.

*Attention* – which is a specific link within the chain of information delivery to man.

*Logic* – this is interrelationship of parts of human memory.

*Memory of attention* – stores information relating to how attention should behave in each and every individual situation.

*Inner world* – is a world within which a human being is thinking and creating.

The anthropological theory of creativity has a definite aim: to separate such notions as "thinking" and "creativity". We believe that there can be no thinking in creativity and there can be no creativity in thinking; "thinking" is working with the products of creativity while creativity is "working" with the products of thinking.

**Ways of information processing:** it is non-verbal in creativeness ("tvorchestvo") and verbal in thinking. Unlike thinking, creativeness ("tvorchestvo") creates no new information, but



is processing the available information in a better way in terms of quality.

Basic **stages**: preparatory (material gathering), “black box” (creative process), acquisition of a product of creativeness.

Criteria for a product of creativeness: integrity; a lot of latent information; impersonal character or neutrality; intransigence and equivalence.

We single out **two ways** of entering into a creative process: a spontaneous creativity (you cannot say when it will happen), compulsory creativity (planned entrance into a creative process). The spontaneous and compulsory creative activities do differ only in particular ways of entering, while being identical.

Creativity functions with no memory of attention participating in it. That is why creative process is not lasting long in terms of time (the utmost concentration of attention leads to human over-tension). Creativity needs a foundation to process information. Creativeness (“tvorchestvo”) is not an accidental but, rather, a definite-goals-achieving process with three ways managing the attention that can be singled out, namely: the memory of attention, direct control, artificial instruments (for example, contradictions).

The future creator will need: to have a desire to find a resolution to an issue creatively; to have a theoretical idea about creativity; to have special skills of entering into creativity state (which can be done with the help of a system of special training or exercises); to get ready for the upcoming creative process (gathering information) and oriented toward the upcoming process rather than its results.

We have developed a specific creativity teaching-learning “technique” to this end.

So, creativeness (“tvorchestvo”) and thinking are different spheres of human intellect and, accordingly, the notion of “creative thinking” is incorrect. We believe that creativeness (“tvorchestvo”) is not an activity. It is instructive to understand the nature of a creativeness (“tvorchestvo”) as of a perfect mechanism which is functioning invariably and nothing else is needed to be introduced into it. It is creativity that needs further development. Quality and skills of a creative person can be improved ad infinitum. Creativity does not

require much concentration of attention and it is used to design a style and form to present the content. Further advancement of creativity would need special teaching-learning methods. But more importantly, it is necessary to understand the nature of creativity and creative process which is represented by our anthropological theory of creativeness (“tvorchestvo”) and creativity.

We use a special “technique” in teaching creativeness (“tvorchestvo”) which we have developed to this end. Basically, it aims to shape learner’s idea about creativeness (“tvorchestvo”). We describe this “technique” of entering into creative process as follows. We advise you to select a rectangular area (a picture) and, within your inner world, concentrate your attention on all that area (without examining the picture and distracting your attention by other thoughts). Wait until the area becomes unstable (starts “trembling”). As a rule, this takes several seconds. Now begins the most complicated phase. Release the area, let it go, but without any reaction to it (your attention does not change, as if nothing has happened whatsoever). If this is done properly, a creative product comes up. A learner, having received sufficient information about the state of creativeness (“tvorchestvo”), will be able to shape his/her own (non-verbal) way of entering into a creative process.

A peculiar property of such a “technique” is manifested in its being verbalized. This “technique” has a shortcoming, i.e. it is verbal, and due to this factor this “technique” should be commented upon intensively. First attempts of many individuals to perform it will fail. That is why it is important to present comments and individually solve the problems relating the performance. Exercises and training are needed to facilitate and ensure their entrance into the state of creativeness (“tvorchestvo”).

Practice has shown that it is irrational to teach the “technique” outright to enable an individual to enter into the state of creativeness (“tvorchestvo”). This can be done a little bit later. From the beginning, it is necessary to explain what creativeness (“tvorchestvo”) is, what the inner world means and is, and get individuals to realize that a creativeness (“tvorchestvo”) is a different “area” within the inner world and that it is not thinking.

Formation of creativeness experience will result in accumulation of patterns of creativeness (“tvorchestvo”) and creativity.

The article is admitted to the International Scientific Conference “Modern problems of science and education”, July, 7-14th 2007, Croatia (Pool), came to the editorial office on 15.05.07

### ON FORMATION OF PROFESSIONAL ACTIVITY STANDARDS IN THE SPHERE OF CONSUMER SERVICES

Rudnik S. Yu.

*Khakassia State University named after Katanov N.F.  
Abakan, Russia*

In our publications we repeatedly raised the problem of competence set formation which is the foundation of service specialties. Today, when all the professional communities found their position in the necessity and demand of creating *Professional Activity Standards*, it seems to be necessary and sufficient for us to carry out the selection of competences making up the foundation of *Professional Activity Standards in the Sphere of Consumer Services*. During three years in Khakassia State University on the basis of Service Technology College, we study the problems concerning the formation of competences which are necessary for our graduates of service specialties (hairdresser, technologist-esthetist). On the basis of the carried out work we marked a range of such competences necessary for a successful professional activity of the above denoted service specialties specialists. Thus, we described the following competence groups with their typical features: *professional psychological competences* (group of competences combining professional socially oriented features characterizing the personality of the specialist); *professional polycultural competences* (group of competences responsible for the introversion of the specialist in the international professional medium, the ability to transpose the international experience into his ethnic sphere); and finally, on the third place we've put *professional competences proper* responsible for the quality

and the possibility of own knowledge and skills using in a concrete professional (or professional pedagogical) situation. Such an order was defined by us from the position of understanding a) entering the speciality (profession), i.e. theoretical justification of the given individual opportunity to master the given speciality (profession); b) the availability of talents for mastering the given speciality (profession) in the wide professional diapason; c) the ability to study the skills necessary for being in the speciality (profession).

Analyzing the experience of the scientists dealing with the problems of competence approach in teaching (Khutorskoy A.V., Kolomiyets B.K., Zeyer E.F., Bordovsky G.A., Bozadzhiev V.L., Zimnyaya I.A. and others) we came to the conclusion that the choice of competences determines the contents of the standard in education, the consequence of which can and should be the *Standard of Professional Activity*.

Besides, it seems to be important for us the observance of succession in professional competence formation. So, it becomes evident that the Standard of Professional Activity for service specialties in Higher Professional Education should be universal and successive for the group of specialties of secondary professional education: 2312 “Cosmetics and Visage”, 2304 “Hairdressing”, 2301 “Organization of consumer services”.

In our opinion, the Standard of Higher Professional Education in the sphere of consumer services should contain a range of distinctive substantial peculiarities. We quote here a fragment of the standard elaborated by us.

1.1. Qualification characteristics of a graduate

The Bachelor of Services should be ready to fulfill the following kinds and tasks of professional activity:

1.1.1. The sphere of professional activity

The sphere of professional activity of a Bachelor of Services involves working in service offices of different fields' and forms' of property firms, in state agencies of federal and municipal value, teaching of service technologies at secondary professional and general professional institutions of various forms of property.

1.1.2. Professiogram

The description of occupations which a Bachelor of Services can master:

Manicurist of II skill-category, Cosmetologist of III-IV skill-category, Hairdresser of III-V skill-category, Make-Up Designer, Podiatrist, Secretary to the Manager (Administrator of Beauty Salon)

The description of specialties which a Bachelor of Services can master:

Technologist-Esthetist, Hairdresser-Stylist, Ministration Organizer on the service shop floor.

The description of positions which a Bachelor of Service can occupy:

Manager of the service office and its branches, Vocational Training Schoolmaster (according branches), Master of Industrial Training (by specialties and professions)

#### 1.2. Competences of a Bachelor of Service

1. *professional psychological competences:*

honesty, prudence, ability to compromise, consistency, creativity, accuracy, duty performance, ability to work in team, employability, wish to learn constantly, educability, psychological stability, communicativeness.

#### 2. *professional polycultural competences:*

ability to take from the international space and adapt to one's own professional activity new and advanced methods of labour organization in the sphere of consumer services, readily integrate into the international community widening one's own proper professional competences.

#### 3. *professional competences proper:*

professional knowledge, abilities and skills corresponding to the qualifying characteristics, professional rivalry, competitive ability, intelligent professional speech, educability.

The competences serve as the foundation for creating the Standard of Professional Activity, which will allow the graduate to orientate in labour market and be prepared to continue the education on the second (Magister) stage of the Higher Professional Education as well as in the sphere of supplementary and After-Higher-School Education, and the employer, in his turn, will be able to make the selection of professionally mature specialists.

---

The article is admitted to the International Scientific Conference "Problems of the international integration of national educational standards", Paris-London, April, 20-27th 2007г., came to the editorial office on 20.03.07

### ON PROJECTING AND PRACTICAL APPLICATION OF INTELLECTUAL TEACHING SYSTEMS AT SPECIALIST TRAINING IN THE AREA OF INFORMATION SECURITY

Rukovishikova S.N., Gritsyk V.A.

*Stavropol State University  
Stavropol, Russia*

In recent years some directions of innovation development have appeared. The powerful innovation motivation emerged as the result of manifestation and development of new scientific achievements and technologies able to elevate educational work onto a brand new stage. Such achievements are present-day computer technologies, the use of which can be considered as a means to change the education quality.

The intellectual teaching systems use and creation experience available allows us to draw a conclusion that at present-day education development level it is necessary to use such an intellectual teaching system which could "manage" students' education in terms of solution of problem situations which they meet in their future professional activity.

The main intellectual teaching system structure component is an intellectual multimedia system where the multimedia integrates various data into one medium, and the processing and keying the multimedia data is performed with the help of artificial intelligence software.

An intellectual multimedia system consists of teaching system units, multimedia and intelligent database, interface and administrative system. The intellectual teaching system functioning peculiarities lie in the fact that its foundation is composed of three interacting against each other modules: the-object-to-study module, the-current-status-of-the-student module and the feedback module. The three mentioned modules perceive and analyse the student's actions, and namely:

- the-object-to-study module analyses the student's actions in terms of the object's work efficiency;

- the-current-status-of-the-student module evaluates the action in terms of the student's standard of knowledge;

- the feedback module considers the action to define the level of the feedback.

The considered scheme of intellectual teaching system allows not only controlling the

standard of students' knowledge and acquired skills, but simultaneously promotes their cognitive activity and guarantees the educational process individualization.

---

The article is admitted to the International Scientific Conference "Modern problems of science and education", Moscow, 2007, came to the editorial office on 13.03.07

### INTEGRATION PROCESS AS CONDITION OF PROFESSIONAL COMPETENCE FORMATION

Shekikhacheva N.I.

*Pedagogical College of KB State University  
Nalchik, Republic of Kabardino-Balkaria, Russia*

Integrative comprehension of real processes and phenomena in the field of pedagogy covers a wide enough range of problems.

In the new millennia the foundation of the educational process for Russia and "its integration into the world's educational space should be formed by the mankind development concept as the part of the society and nature interaction process; humanity, forming a need to be life-time educated".

One of the current problems of professional education is the problem of continuous education system creation.

In the materials of the international symposium "Secondary education for Europe" (Bern, 1996) a general opinion that if we want to give the younger generation a chance to success, then it is important to define the key competences, is fixed.

The Kabardino-Balkaria multiversity, created 10 years ago and being converted into Bologna system includes also a pedagogical college. The becoming and development of the hierarchical structure of this higher education institution increases the flexibility of general cultural, professional and scientific training of specialists taking into account changing demands of economics.

Within the frame of the multiversity the continuous subjects teaching is practiced, mathematics being among them. The requirements of national educational standards of

all professional education levels are taken as the foundation to make the content.

To provide the education content continuation "horizontally" on the level of higher professional education we offer using an approach, at which the content is considered to be the academic information consisting of academic elements' combination.

It takes into account home and foreign experience of Higher School development and the international education classification accepted by UNESCO, meets the need to form the national educational standard within the frame of the world's community.

Projecting the academic process while training a future Mathematics teacher. The predominant objects of the pedagogical process are: the competence formation trajectory, the academic process, the methodical teaching system.

The competence formation trajectory figures a project of an academic process developed within the integration system "Pedagogical College – University". One of the main parameters of arithmetic reasoning is operational efficiency, flexibility, criticism, the ability to review a situation and to find the ways out of crisis situations. These traits suppose the availability of the following skills in students:

- logical and algorithmic cogitation;
- modeling of processes of problems solution;
- optimal solution method evaluation;
- rational solution method selection;
- present-day information technologies application.

The result of such professionalization is the motivation growth with higher education programs study, the solidarity of general, secondary and higher education, and the integration principles realization.

The trajectory of the future teacher professional becoming is divided into three portions: academic training, general educational development and student teaching.

To essentially signified characteristics of the developed technology of a Mathematics teacher training in a pedagogical college under the conditions of regional educational concept we refer the need of practice:

- scientific – practical activity skills and the educational process correction.

In the foundation of the projecting activity lie the ideas of simulation of such an educational process, such a system functioning trajectory, which inevitably leads to the planned results.

New professional tasks, one of the most actual ones of which is the organization of activity under permanently changing conditions in such a way, so that the graduates' knowledge had an advanced professional trend.

To be competent means to be able to mobilize the knowledge and experience available, one's own mood and will to solve a problem under specific life circumstances. Competence is directly proportional to activity, to

acknowledged attitude of a human to his own education.

The solidarity of general, secondary and higher education and realization of integration, consistency and fundamentality principles.

---

The article is admitted to the International Scientific Conference "Problems of the international integration of national educational standards", Paris-London, April, 20-27th 2007 , came to the editorial office on 02.03.07

## METALS FRACTURE MICRO MECHANISM AND PLASTIC ZONES FORMATION AT THE CRACK TIP

Klevtsov G. V., Klevtsova N. A., Frolova O.A.

Orenburg State University, Orenburg, Russia

---

Fracture micro mechanisms, plastic zones formations and local stress state at the crack tip in materials possessing a BCC-lattice structure and FCC-lattice structure were studied by the X-ray diffraction method. Specimens were tested under single, cyclic and impact- cyclic fracture modes. It was shown two plastic zones are formed under the ductile fracture in plane stress state condition (PS). One plastic zone is formed under the brittle fracture in plane deformation condition (PD). Generalizing scheme of plastic zones formation at the crack tip according to load ratio R is presented.

Under single and cyclic fracture modes in plane stress state condition (PS) and plane deformation condition (PD) martensitic transformation after crack propagation is possible. Character of martensitic phases distribution in plastic zones under the fracture surface is connected with fracture micro mechanism and local stress state at the crack tip.

---

### Introduction

Today, requirements to both structural materials and techniques for evaluation of material reliability and quality are very high. A special attention is spared to elaboration of new, physical grounded criterions of mechanical behaviour of materials. Elaboration of new, physical grounded criterions of strength and plasticity is possible only on the basis of physics, material science and fracture mechanics that is within the limits of new scientific direct – fracture micromechanics. Using of ideas and methods of micro mechanics for study the nature of strength and fracture is connected with local methods of fracture investigation. X-ray diffraction analysis is one of these methods allowing investigate plastic zones under the fracture surface, determine the depth of these zones, crystalline structure distortion, phase transformation and also phase distribution within plastic zones. Plastic zones forming at the tip of propagating crack are binding link between structure and mechanical properties of metal and also characterize the behaviour of material under loading condition. A local stress state at the tip of propagating crack influences on the crystalline structure distortion, and, consequently, on martensitic

transformation taking place during both deformation and fracture. And the distortion of crystalline structure and, in particular, martensitic transformations at the crack tip influence on kinetics and fracture mechanism. However, martensitic transformations in plastic zones at the crack tip are studied not enough. Results of complex investigation of the interrelation between local stress state, local heating at the crack tip, plastic zones formation, distribution of martensitic phases within plastic zones, and, also fracture micro mechanism are presented.

### Materials and experimental techniques

Materials employed in this study were steels having Body-Centered Cubic Lattice (BCC) structure: carbon steels - Steel 15 (0.15 %C), Steel 20 (0.18 %C), Steel 40 (0.39 %C), Steel 45 (0.45 %C), St 3 (0.2 %C), medium-alloyed steel 15X4MΦA (0.15 %C, 2,75 %Cr, 0.8 %Mo, 0.6 %Mn, 0.4 %Ni) and materials with Face-Centered Cubic Lattice (FCC) structure: aluminum deformed alloys - D16 (4.5 % Cu, 0.6 %Mn, 0.2 %Si, 1,5 %Mg, 0.12 %Zn, 0.23 %Fe), AK6 (2.22 %Cu, 0.6 %Mn, 0.9 %Si, 0.6 %Mg, 0.5 %Zn, 0.7 % Fe, 0.1 % Ni), austenitic steels – H32T3 (0.03 %C, 32.1

%Ni, 3/2 %Ti), H26T3 (0.035 %C, 26.6 %Ni, 3.18 %Ti), H26X5T3 (0.03 %C, 4.2 %Cr, 26.0 %Ni, 2.7 %Ti), 40Г18Ф (0.42 %C, 17.96 %Mn, 0.09 %Cr, 1.22 %V), 40X4Г18Ф (0.43 %C, 18.0 % Mn, 4.2 %Cr, 1.41 %V), 03X13AГ19 (0.03 %C, 19.35 %Mn, 13.5 %Cr, 0.74 %Ni, 0.17 %N), 07X13H4AГ20 (0.06 %C, 21.87 %Mn, 14.86 %Cr, 4.89 % Ni, 0.14 % V), 110Г13Л (1.06 % C, 15.18 % Mn, 0.2 %Cr, 0.4 %Ni).

Carbon steels were subjected to following treatments i) steel 15 and steel 20 – annealing ii) steel 40 – hardening +intermediate tempering, iii) steel 45 – annealing + hot-rolling iv) St 3 - hot-rolling v) 15X4MΦA – hardening + high tempering vi) D16 – hot-rolling + quenching + aging. Austenitic steels were solution heat treated by heating at 1100 °C (40Г18Ф, 40X4Г18Ф), 1050 °C (110Г13Л), 1150 °C (other steels) followed by water quenching. After quenching steels H32T3, H26T3, H26X5T3, 40Г18Ф, 40X4Г18Ф were subjected to an aging treatment both at different temperature and aging time. The steels 03X13AГ19, 07X13H4AГ20 and also steel 110Г13Л were used after quenching. After all heat treatment specimens were tested under static, impact, high-speed impulse, cyclic and also impact-cyclic loading conditions at the temperature interval ranging from -196 to +150 °C. The fracture surfaces of all specimens were observed by macro and micro fractography. Both plastic zones depth under the fracture surface, change of the crystalline structure distortion and martensitic transformations within plastic zones were determined by X-ray diffraction method employing improved by authors chemical etching technique [1].

For determination of the material local stress state at the crack tip improved by authors criterion  $h_{max}/t$  was used [2, 3], where  $h_{max}$  – maximum plastic zone depth under the fracture surface,  $t$  – sample thickness. If the fracture occurs under i) a plane deformation (PS) the ratio  $h_{max}/t < 10^{-2}$ ; ii) a plane stress state (PS) the ratio  $h_{max}/t > 10^{-1}$ ; iii) transition from PD to PS the ratio  $10^{-2} < h_{max}/t < 10^{-1}$ .

Plastic zones and material local stress state under simple loading conditions. Plastic zones forming at the crack tip under simple loading conditions in PD and PS are distinguished by both form and size that effect on both fracture mechanism and crack propagation resistance. Moreover, under investigation of plastic zones formation during fracture ought to take in consideration next circumstances. In first, during some materials fracture (for instance, in materials with FCC – lattice during combined fracture), besides limited values of material local stress condition, the transition from PD to PS at the crack tip can be realized [4]. Second, according to many experimental data [1-4], two plastic zones i) lowly deformed macro plastic zone  $h_y$  and ii) highly deformed micro plastic zone  $h_{yh}$  distinguishing by size and degree of crystalline lattice distortion are formed at the crack tip during fracture under PS and also sometimes under transition from PD to PS. Elaborated by authors the scheme of plastic zones formation under the plane stress state is shown in Figure 1 [1, 2].

Thus, during fracture of materials having both BCC-lattice structure and FCC-lattice structure under PS condition two plastic zones i)  $h_y$  and ii)  $h_{yh}$  are formed at the crack tip. The ratio  $h_{max}/t > 10^{-1}$ . The ductile fracture in a micro-void coalescence manner is observed.

Only one plastic zone  $h_y$  is formed at the crack tip when the fracture occurs under PD condition. The ratio  $h_{max}/t < 10^{-2}$ . Materials having BCC-lattice structure are fractured under PS condition always by cleavage (transcrystalline fracture) or intergranular mechanism; materials having FCC-lattice structure – by intergranular mechanism or combined mechanism, but intergranular mechanism or cleavage is predominate. Such fracture mechanisms cause lower level of crystalline structure distortion (determined on diffraction line width) in plastic zone as compared with ductile mechanism. In case when material fracture occur under transition state from PD

to PS the ratio  $10^{-2} < h_{\max}/t < 10^{-1}$ . Lowly deformed plastic zone depth  $h_y$  under the fracture surface is much lower then under PS condition. Still to distinguish micro and macro zones is difficult because of small size of these zones. Mainly materials with FCC-lattice structure fracture in transition state from PD to PS, and, as a rule, by combined

mechanism. Under combined fracture mechanism crystalline structure distortion on the fracture surface commensurable with crystalline structure distortion in highly deformed plastic zone under ductile fracture. Apparently, low materials fracture energy under combined fracture mechanism is conditioned by little micro plastic zone size.

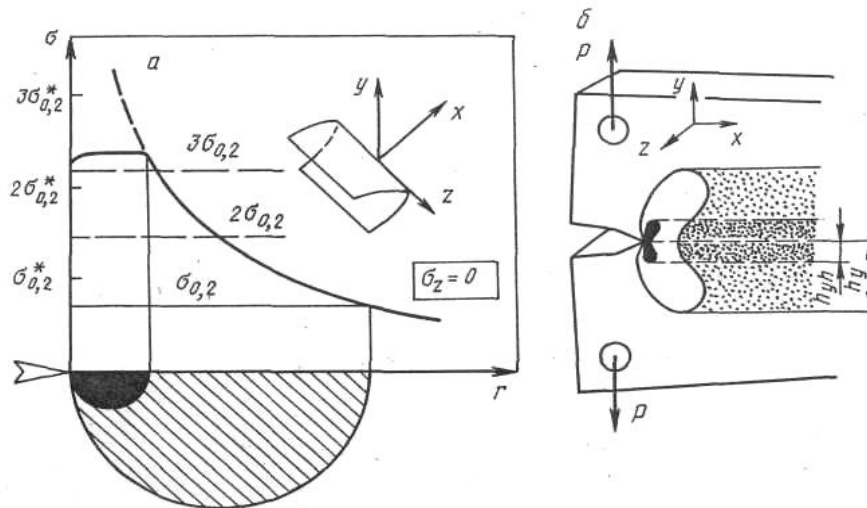

**Figure 1.** Scheme of plastic zones formation at the crack tip (a) and under the fracture surface during crack propagation (b) under plane stress state when the ratio  $h_{\max}/t > 10^{-1}$   
 $h_y$  – the depth of lowly deformed macro plastic zone;  $h_{yh}$  - the depth of highly deformed micro plastic zone

The change of material local stress state at the crack tip as was shown in author's works, effect both on plastic zone depth under the fracture surface and level of crystalline structure distortion within this zone. For determination crystalline structure distortion the ratio  $\beta/\beta_0$  where  $\beta$  is a diffraction line width obtained by X-ray diffraction of plastic zones,  $\beta_0$  - diffraction line width obtained by X-ray diffraction of nondeformed metal has been used [1-4]. It was shown, when the fracture is not accompanied by phase transformations in plastic zones, the relations between ratio  $h_{\max}/t$  and ratio  $\beta/\beta_0$  are described by general curves independence from material class and also kind of simple loading condition. The ratio  $\beta/\beta_0 \leq 2.0$  under PD condition;  $\beta/\beta_0 = 2.0-2.1$  under transition from PD to PS;  $\beta/\beta_0 \geq 2.1$  under PS condition during fracture. It's

impossible to determine such correlation between ratio  $\beta/\beta_0$  and stress state at the crack tip if martensitic phases or deformation twin are formed on the austenitic steels fracture surface.

Plastic zones formed under cyclic loading. According to Rice's theory [5] two plastic zones i) monotonic plastic zone (or yield zone)  $h_y$  and ii) cyclic plastic zone (or reverse deformation plastic zone)  $h_{yh}$  are formed at the fatigue crack tip under cyclic loading condition. In recent author's works was shown [1-4] the relation between cyclic plastic zone depth  $h_{yh}$  and applied maximum stress intensity factor  $K_{\max}$  and also the relation between monotonic plastic zone depth  $h_y$  and applied stress intensity range  $\Delta K = K_{\max} - K_{\min}$  are independent of material class, loading conditions and also load ratio  $R = P_{\min}/P_{\max}$ . These relations are described by



general curves to a good approximation to equations [1]:  $h_y = 0.0354(K_{max}/\sigma_{0.2})^2$  and  $h_{yh} = 0.0012(\Delta K/\sigma_{0.2})$ .

Plastic zones formation general scheme under different values of load ratio R and also applied stress  $\sigma$ , including plastic zones formation under compression loading is offered by authors.

In most cases material fracture took place under transition state from PD to PS when the criterion  $10^{-2} < h_{max}/t < 10^{-1}$  or under PS condition when the criterion  $h_{max}/t > 10^{-1}$ . In case fatigue fracture the general relation

between  $h_{max}/t$  and  $\beta/\beta_0$  is not discovered [1-4]. Therefore may to state using of the ratio  $\beta/\beta_0$  as a criterion of the material local stress condition at the crack tip is not possible.

Obtained results have been served basis for elaboration of new scientific direct – X-ray fractodiagnotics. Due to X-ray fractodiagnotics knowing plastic zones depth under the fracture surface and also change of crystalline structure in these zones loading parameters causing the fracture can be determined.

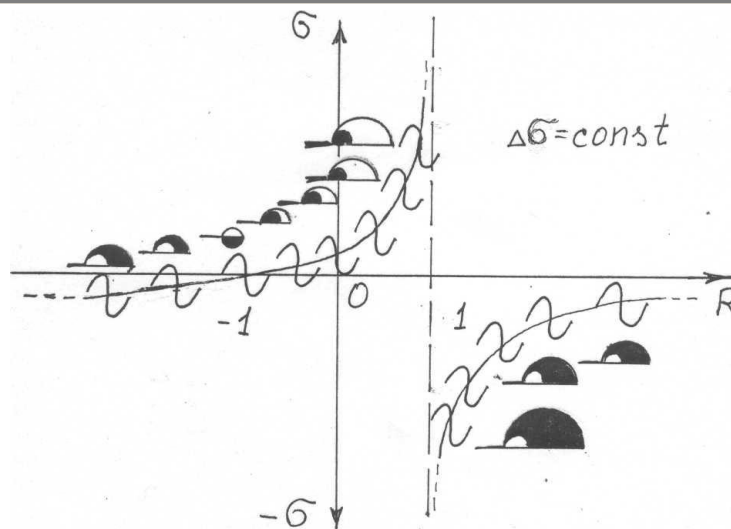

**Figure 2.** General scheme of plastic zones formation at the crack tip under different values of load ratio R and also applied stress  $\sigma$  (for case when  $\Delta\sigma = \text{const}$ ). Local stress state corresponds to bond between PD condition and transition from PD to PS

Regularities of martensitic phase distribution in plastic zones under different types of austenitic steels fracture. In austenitic Fe-Ni steels where take place  $\gamma \rightarrow \alpha$  martensitic transformation during deformation and fracture, for example, quenched steel H32T3, fractured in PS condition by ductile mechanism  $\alpha$ -martensite quality within micro plastic zone  $h_{yh}$  is about constant in spite of monotonic change of crystalline distortion through the depth from fracture surface. Quantity of  $\alpha$ -martensite decreases quickly under traverse in lowly deformed plastic zone  $h_y$ . Described

distribution of  $\alpha$ -martensite within highly deformed micro plastic zone is conditioned by two main factors i) deformation level and ii) material local heating at the crack tip during the fracture. Deformation is favorable for the martensitic transformation. The local temperature at the crack tip prevents from martensitic phase formation. After crack propagation layers on and near the fracture surface cool down to the test temperature and cooling martensite can be formed in ones. Apparently therefore there is a gap between  $\alpha$ -martensite distribution and crystalline distortion gradient.

In plastic zones of quenched Fe-Mn and Fe-Cr-Mn austenitic steels, for example, steel 03X13AГ19 fractured at temperature  $-196^{\circ}\text{C}$  by brittle or combined (brittle + ductile) mechanisms,  $\alpha$ -martensite and also  $\varepsilon$ -martensite are formed.  $\varepsilon$ -martensite is brittle phase apparently. Therefore the strong material local heating is not occur under present steels fracture. Fracture takes place in transition state from PD to PS. Quantity of  $\alpha$ -martensite decreases from the fracture surface to the depth of plastic zone in agreement with the crystalline structure

distortion change in one. Quantity of  $\varepsilon$ -martensite increases from the fracture surface to the depth of plastic zone, and, as a role, maximum quantity is discovered on the some depth from the fracture surface where deformation less then fracture surface.

Aged Fe-Ni steels, for example, steel H32T3, fractured by brittle intergranular mechanism in PD condition or near PD condition under low temperatures impact test. In this case quantity of  $\alpha$ -martensite decreases from the fracture surface to the depth of plastic zone (Figure 3).

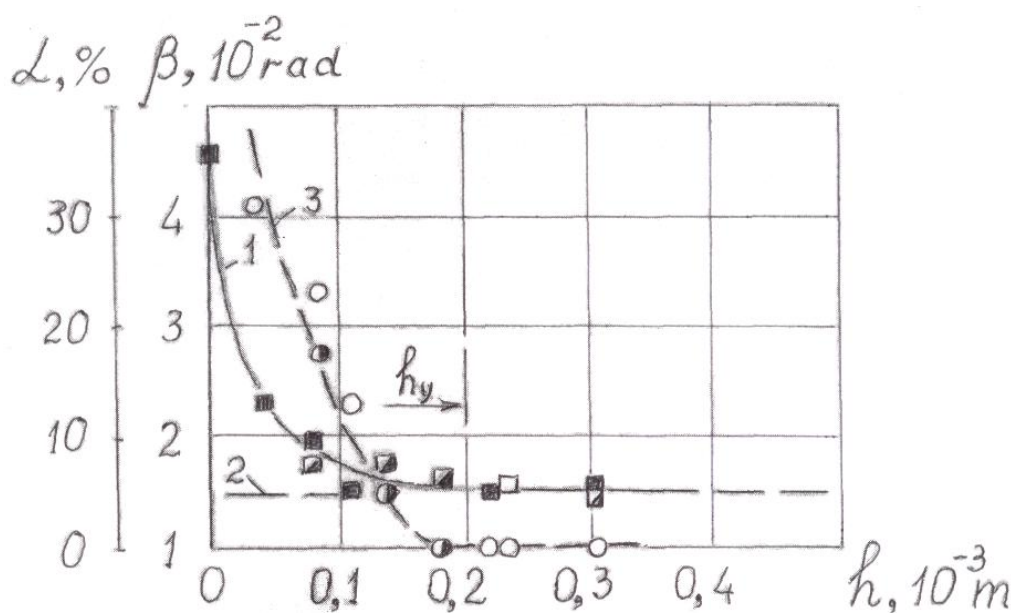

**Figure 3.** Relation between diffraction line width  $(311)K_{\alpha}$  (1, 2),  $\alpha$ -martensite quantity (3) and distance from the fracture surface of aged steel H32T3 tested impact under  $-196^{\circ}\text{C}$ ; 1- diffraction line width  $(311)K_{\alpha}$ ; 2- nondeformed metal diffraction line width  $(311)K_{\alpha}$ ; 3-  $\alpha$ -martensite quantity; Light and dark spots – specimen 1; combined spots – specimen 2

By this means under the ductile fracture of austenitic steels in plane stress condition (PS) after crack propagation line superficial layers cool down and possible the martensitic transformation in one. Under the brittle fracture in plane deformation condition (PD) after crack propagation line in superficial layers possible the martensitic transformation induced the change in the local stress state from PD to PS. Such martensitic phases distribution in plastic

zones is typical for all single fracture modes (static, impact and high-speed impulse tests).

Under cyclic test regularity of  $\alpha$ -martensite and  $\varepsilon$ -martensite distribution in plastic zones as well as under single fracture modes although plastic zones formation character is differ in nature (4). Quantity of  $\alpha$ -martensite under cyclic fracture surface decreases progressively from the fracture surface to specimen depth. Maximum  $\varepsilon$ -martensite quantity under fracture surface is occurred where deformation less than on the

surface. When the fatigue crack length increases (increase  $K_{max}$ ) the plastic zones depth increases too. Consequently, the local stress state changes to plane stress state. By this means quantity of  $\epsilon$ -martensite under fracture surface is likely to decrease.

Relying on such experiments, it may be inferred that character martensitic phases distribution in plastic zones under the fracture surface is not depends of mode and load speed of austenitic steels specimens, except that depends of the fracture micro mechanism and the local stress state materials at the crack tip. Load speed influence on intensity of martensitic transformation in plastic zones only. Under cyclic test of austenitic steel martensitic transformation intensity on fracture surface low than under single fracture modes.

This investigation was carried out with the financial support of Russian Fond Base Researches (№ 06-08-96904p\_офи).

**References:**

1. G.V. Klevtsov: Plastic Zones and Diagnosis of Metallic Materials Fracture, MISIS, Moscow, 1999, 112.
2. G.V. Klevtsov, L.R. Botvina, N.A. Klevtsova: Plastic Zones Formation under Different Types of Loading Conditions, ISIJ International, Jpn., Vol.36, 2, (1996), 215.
3. G.V. Klevtsov, L.R. Botvina, N.A. Klevtsova: X-ray Diffraction Technique for Analysing Failed Components, ISIJ International, Jpn., Vol. 36, 2, (1996), 222.
4. N.A. Klevtsova, O.A. Frolova, G.V. Klevtsov: Austenitic Steels Fracture and Martensitic Transformations in Plastic Zones, Academy of Natural Science, Moscow, 2005, 155.
5. J.R. Rice: Mechanics of Crack Tip Deformation and Extension by Fatigue, ASTM, Special Technical Publication, 415, (1966), 247.

*Materials of the Conferences*

**ANALYSIS OF STRESS AND STRAIN  
STATE OF PLATES AND SHELLS WITH  
DUE CONSIDERATION OF MATERIALS  
DAMAGEABILITY THANKS TO TIME-  
DEPENDENT DEFORMATION AND HIGH-  
TEMPERATURE HYDROGEN  
CORROSION**

Belov A.V., Polivanov A.A., Popov A.G.

*Kamyshin Technological Institute*

*Branch of Volgograd State Technical University*

*Kamyshin, Volgograd Region, Russia*

The most important problem of energy and petrochemical as well as aircraft engineering development is the creation of new generation arrangement rendering possible realization of strict operating practice of exploitation (high temperature, pressure, speed, environmental aggressiveness, etc.) and providing high reliability and specified life. For designing such constructions the elaboration of design complexes rendering possible to carry out the investigation and behavior simulation of such constructions taking into account the attack of non-steady temperature, force field and degradation of mechanical-and-physical properties of their materials. The specified complexes including quite a number of basic intersystems should operate from mathematical models describing the evolution of stress and strain state of the constructions under the conditions of their near-real exploitation loading. In this connection the elaboration of system concept of construction of such design complexes both from methodological point of view and from the position of construction of integrated functional design of interdependent models rendering possible to solve complex problems passing from their simple statement to a more complicated one becomes of the current interest. System approach oriented integrated studies meant for a large variety of important engineering problems are carried out by the authors, among them:

- computing and valuation of loading capacity of non-uniform sandwich shell structures used in energy and petrochemical engineering, working in conditions of complex thermo-force loading, causing development of

irreversible deformations, damageability of materials due to creeping and attack of aggressive media;

- design of optimal from the viewpoint of resistant durability, life duration and materials consumption of the structures as applied to concrete activities;
- valuation of wide class remaining life of highly stressed and dangerous from the after-effect viewpoint of failure of the structures (body frame of chemical reactors, parts of gas turbines and electric power installations, variators and other products of heavy-duty production) being at present time in use.

In the work presented here the concept of system approach to investigation method development and simulation of thermo-visco-elastic-plastic stress and strain state of non-uniform sandwich shell structures with account of materials damageability due to creeping and hydrogen corrosion.

At that the models determining the structures behavior and integrated into a complex are constructed with due consideration of present-day state of theoretical research and experimental data on fullness and adequacy of the considered physical and mechanical processes description. If necessary the models are complicated on account of their correlation. For this a hierarchic approach to the formation of model system realizing the principle "from simple to complex" is used, when the next difficulty level is reached after detailed enough study of a more simple model. Hence, a multilevel architecture of more and more complex models every one of which correlates the previous ones including them as special cases.

The developed in such a way method of solving a complex problem on valuation of durability, toughness and life time of quasistatically loaded sandwich envelopes of rotation according to the correspondent parameters' predetermined values allows performing accounting in various statements. Let us consider every of the possible problem statements in a more detailed way.

1. Thermo-elastic statement of the problem.

Here a linear dependence of stresses on strains is intended, the dependence of a material properties on temperature comes

into account by means of definition of mechanical properties of the material for different fixed values of temperatures. The construction failure is not intended.

2. Thermo-elastic-plastic statement of the problem. In this case the material behavior law is supposed to be linear only within the proportional limits, and for irreversible deformations development modeling the following things can be used:

- simple straining process theory (theory of small elastoplastic deformations) – in case of steady thermo-force loading;
- theory of nonisothermal processes of elastoplastic deformation of solid body elements in the path of flatness (theory of flow with isotropic hardening) – in case of non-steady thermo-force loading with the possibility of loading history investigation. Depending on loading conditions and mechanical properties of envelope materials for its bearing resistance valuation the use of one of the three sudden fracture criteria is possible: the Rankin, Tresca-Guest or Huber-Mises one.

Besides, stress and strain structures' calculations performing is possible also taking into account high-temperature hydrogen corrosion. To do it the methodology is enriched with a generalized model of hydrogen-containing medium attack to the construction.

3. Thermo-visco-elastic-plastic statement of the problem ignoring materials damageability at creeping. Here, in addition to the previous problem statement, the deformation adaptability in time due to the envelope materials' creeping is intended; it comes into account by means of introduction of creep strains into constitutive equations. At that, one of either prompt or long-term strength criteria can be used as the envelope fracture criterion.

4. Thermo-visco-elastic-plastic statement of the problem inclusive materials damageability at creeping. In the specified problem statement it is supposed that the creep strain development will be attended with damage accumulation in the envelope material that finally can lead to its fracture as well. At that, the scalar parameter of damageability  $\omega_c$  is accepted as a measure of the material damageability in the process of creep strain development.

To describe the process of damage accumulation in a material due to creeping the kinetic damageability equation of Rabotnov Yu.N. is used.

As the equivalent stress one of the criteria of long-term strength - Johnson, Kats, Sdobyrev, Trunin or Lebedev-Pisarenko – can be used. The choice of a creep rupture strength criterion describing the material's damageability process at creeping most adequately depends on the kind of stress state, stress level and availability of enough test data.

The process of damage accumulation in the material of the studied shell is calculated by means of successive solutions of the kinetic damageability equation in every loading step. The investigation of the damage accumulation process in the shell element lasts until achieving a preset limit value close to the unit by the  $\omega_c^*$  parameter. It is the condition of the shell's local fracture (i.e. fracture process beginning).

5. Thermo-visco-elastic-plastic statement of the problem inclusive materials damageability at creeping with fracture propagation stage investigation. The problem solution in such a statement supposes the shell's fracture propagation stage investigation. To do it for a first approximation the method offered by Kachanov L.M. and based on fracture front edge (the surface demarking the destroyed and yet undestroyed areas of the material) stroke study is used. The moment, at which the front edge stroke speed increases sharply (ten and more times as much) or when in separate most loaded points intolerably large deformations exceeding 5% are accumulated, is accepted as the total fracture time. The fracture front edge stroke speed is defined as the ratio of fracture front edge stroke to the period of time during which this stroke takes place.

Thus, the authors have developed the sandwich envelope structures' behavior modeling and research methodology which allows describing the following kinds of its stress and strain state:

- thermo-elastic;
- thermo-elastic-plastic inclusive and exclusive hydrogen corrosion;
- thermo-visco-elastic-plastic ignoring materials damageability at creeping;
- thermo-visco-elastic-plastic inclusive materials damageability at creeping;

- thermo-visco-elastic-plastic inclusive materials damageability at creeping and hydrogen corrosion;
- thermo-visco-elastic-plastic inclusive materials damageability at creeping and hydrogen corrosion with damageability areas propagation kinetics.

At developing this methodology the following was used: the linearized by the method of additional strains correlations of the theory of nonisothermal processes of elastic-plastic straining of solid body's elements in the path of flatness; kinetic equations of materials' damageability at creeping and hydrogen corrosion.

Using the developed methodology a range of applied problems on stress-strain analysis of single- and multilayer envelopes of rotation at various loading conditions, and that is:

- uniformly heated up three-layer cone shell rotating with constant angular velocity;
- double-layer spherical shell with various banding and loaded with intrinsic pressure;
- thin double-layer envelope of rotation with an irregular shape of meridian in the form of a vessel at its internal pressure loading;
- double-layer rotation shell representing an axial compensator loaded simultaneously with intrinsic pressure and shifting motion of its end faces;
- uniformly heated up cyclic plane dependent upon high-temperature hydrogen from one of the sides.

---

The article is admitted to the International Scientific Conference "The newest technological decisions and the equipment", May, 14-16th 2007, Moscow, came to the editorial office on 23.04.07

#### **SECONDARY POWER SOURCES WITH CAPACITORS IN POWER CIRCUIT**

Magazinnik L.T.

*Ulyanovsk State Technical University  
Ulyanovsk, Russia*

Single-phase secondary power sources (SPS), due to their little specific gravity (kg/kW) and quick response, got wide spread occurrence within the limits of power from tens of W

(household audio- and video facilities) to some kW (electronic voltage stabilizers, plasmatron ion source feed elements of moderate capacity, electric arc welding devices, etc.) [1].

One of significant disadvantages of a "classical" SPS is a low phase factor ( $F_p$ ) equal to 0,3...0,4 and conditioned by impulse character of the consumed current from the system.

For the purpose of the  $F_p$  increase an active filter on the input of the invert circuit is used, which is sometimes called the  $F_p$  adjuster. For the filter power key control a range of well known firms ("Micro Linear", "Simens", "Motorolla") have developed special electronic chips providing quasi-continuous character of the line current and  $F_p$  increase up to 0,86 with simultaneous invert circuit constant-voltage regulation [2].

In [1,3] a modified algorithm of active filter control and the scheme of the algorithm realization are offered, that provides the  $F_p$  increase up to 0,95 and more meeting the hardest demands of the IEC (IEC-1000-3-2).

Notice that the SPS power part complication connected with the active filter application is made up with the fact that together with the  $F_p$  increase and invert circuit out voltage stabilizing treatment the filter condenser capacity value decreases by about 60 %.

Further SPS updating in terms of specific gravity decrease and loss enhancement, for example, has the following limitations:

- because of the invert circuit out voltage unbalance the power isolating transformer is performed gapped in the heart and is used only in the incremental hysteresis loop, that makes the bicyclic invert circuit bridge network be non-effective compared to a single-pulse one, and, finally, leads to the transformer mass-volume showings increase;
- the invert circuit out voltage line-locked frequency increase allows reducing the transformer and smoothing inductor frames, however, the power transistors' losses increase at that. The last especially matters for powerful SPS.

The switching on the capacitors in series into the power transformation primary circuit allows excluding the invert circuit out voltage continuous component, and also, in some cases, reducing commutative losses in power transistors.

Two SPS networks with condensers in the invert power circuit are considered below: a half-bridge and full-bridge ones.

The half-bridge network provides a push-pull transformer work mode with a total absence of continuous component in the voltage curve. It allows using the heart without air isolation and with high degree of hysteresis loop rectangularity. Hence, the transformer frames and its losses can be reduced (at the same frequency) two-fourfold compared to the networks [2] without condensers.

The indisputable advantage of this network is the invert power circuit simplicity (push-pull mode is provided by only two power transistors). Respectively, the controlling system is also simplified.

The bridge network provides a push-pull transformer work mode and, respectively, its full use. The quantity of power transistors and outlets of the invert circuit controlling system in this network is twice as many, however, there is only one commutating capacitor and its band capacitance is eight times as much against the total capacitance of the capacitors in the half-bridge network.

Reduction of the compared versions to one and the same load gives absolutely identical both gain and rectified voltage regulation characteristics of the invert circuits. Voltages across power transistors in both versions are also identical and equal to the voltage of the invert circuit input; however, the current amount through the bridge invert circuit is twice as little. Hence, the total "installed capacity" of the power transistors in both networks is equal.

**Conclusions:**

1. Including capacitors into the power transformer primary invert circuit gives an opportunity to apply the heart of this transformer without air isolation, with little field current and using on a complete hysteresis loop, that allows reducing its mass-volume showings essentially.
2. In permanent output the current through invert circuit transistors has an intermittent nature, i.e. the transistors' commutation is currentless, losses are minimal, that allows increasing the line-locked frequency and, respectively, decreasing mass-volume showings of the SPS.
3. The two considered SPS networks with capacitors in the power circuit are identical

on their voltage regulation characteristics, however, the bridge network (excepting the low power SPS) are preferable against the half-bridge one.

**References:**

1. Magazinnik A.G., Magazinnik L.T., Magazinnik G.G. Secondary power sources phase factor correction. "Electrotechnics"/"Electrotechnica", № 5, 2001, pp. 40-42, Moscow.
2. Pryanishnikov V.A. Electronics, 1998, p. 400.
3. Patent № 2178234 PΦ/RF. Secondary power source / Magazinnik L.T., Magazinnik G.G. Published 10.01.2002. Bulletin № 1. Priority from 13.02.2001.

---

The article is admitted to the V conference "Modern high technologies" February, 21-28st, 2007, Egypt (Hurgada), came to the editorial office on 27.04.07

**TRANSISTOR CHOPPERS FOR ELECTRIC-ARC WELDING**

Magazinnik L.T.

*Ulyanovsk State Technical University  
Ulyanovsk, Russia*

A disadvantage of native and foreign secondary power sources (SPS) designed for electric welding is the fact that current amplitude in the invert circuit power transistors of the specified SPS designed for electric welding units is great and makes about one third of the load current output, i.e. in the electric arc. The specified disadvantage is explained by the fact that in order to stabilize the electric arc "combustion" and its easy "ignition" the denoted devices designers have to make the matching transformer secondary voltage greatly overstated compared to the arc voltage and equal to about 100V.

At the same time it is known that in practice the arc voltage does not exceed 25V when welding in the air, and when welding in CO<sub>2</sub> and argon the arc voltage is considerably lower. The described disadvantage, i.e. voltage uprating, leads, first - to cost and power excursion of the invert circuit transistor; second - to their losses increase.

For this essential fault elimination a new SPS network [3] is offered, in which the matching

transformer is provided with a supplementary secondary winding with an in-series capacitor, that has allowed imposing the “ignition” function and that of electric arc stabilization in the field of low currents on a supplementary power source and reducing the voltage of the matching transformer main secondary winding up to 35V and, in such a way, reducing the invert circuit transistor current amplitude almost thrice.

The device performed according the offered network is characterized by the following voltage regulation characteristics:

1. The main power source voltage regulation characteristic ( $U_1$  chart 1) – is typical of the system closed in current. The characteristic is depicted perfectly stiff. Really, it has a little inclination conditioned by the supply

$$U_m = \frac{1}{c} \int_0^{\tau} i \cdot dt \approx \frac{I_{kp} \cdot \tau}{c}, \quad (1)$$

as during the time  $\tau$  the load current is reputed to be invariable ( $\tau \approx 10^{-5}$  c).

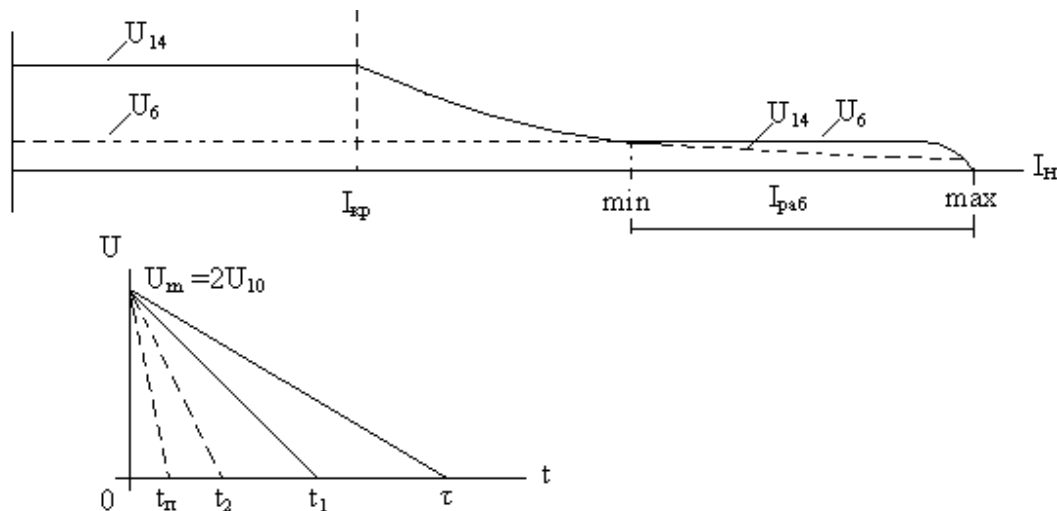

By analogy, the voltage excursion in the mode  $I > I_{kp}$

$$U_m = \frac{1}{c} \int_0^t i \cdot dt \approx \frac{I_t \cdot t}{c} \quad (2)$$

As the voltage excursion  $U_m$  in the compared modes is identical, the expressions (1) and (2) can be equated:

$$\frac{I_{kp} \cdot \tau}{c} = \frac{I_t \cdot t}{c} \Rightarrow \frac{I_{kp}}{I_t} = \frac{t}{\tau}. \quad (3)$$

main impedance and internal impedance of the device itself.

2. The supplementary power supply voltage regulation characteristic ( $U_2$  chart 1) at load currents  $I_H \leq I_{kp}$  linear and hard, as the capacitor doesn't manage to charge during the time of the  $\tau$  half cycle to auxiliary secondary winding voltage excursion and that is why (if neglecting significant losses in the capacitor) doesn't influence the amount of half- period average voltage  $U_2$ . At  $I_d > I_{kp}$ (chart 1) the capacitor charges up to the voltage excursion during the time  $t_1 < \tau$  (chart 2). The rectified voltage amplitude in the capacitor at  $I_d = I_{kp}$



But in concordance with the chart 1  $t_1/\tau = U_{d(t_1)}/U_{d(\tau)}$ , where  $U_d$  is the half-period average voltage. Thus,  $I_{kp}/I_t = U_{d(t)}/U_{d(\tau)}$ , from which  $I_{kp} \cdot U_{d(\tau)} = I_t \cdot U_{d(t)} = cons$  at any  $t < \tau$ .

So, in the field  $I_{kp} < I < I_{pa\bar{o}.min}$  the supplementary power supply has got a hyperbolical voltage regulation characteristic with load constant power:  $P_d = U_d \cdot I_d = cons$ , that is ideally suited for the electric arc in the air.

At  $I > I_{pa\bar{o}.min}$  the supplementary supply is locked as its voltage is lower than that of the main source, and, finally, at  $I = I_{max}$  the voltage of both sources verges towards the null tight under the influence of the current feedback within the system of the invert circuit control.

From the quoted diagrams one can see that in the field of operating load currents (welding) the supplementary source, i.e. diode bridge, is locked. At the same time relatively high open circuit and small current voltage provides an easy "ignition" and the arc maintenance at small currents.

In the known secondary power sources the secondary winding voltage of the matching transformer, as it is shown above,  $\approx 100$  V.

In the offered device voltage is lowered up to 35 V, it means that at the load current equal to those of the specified devices, the voltage excursion in the invert circuit transistors will be  $100/35 \approx 2,85$  times as little, that is rather vital as the power transistors or solid-state compound modules, first, make up an essential part of the total cost of the device; second, the reduction in current reduces losses. Notice, that the losses in the secondary power source are ignorable as it is switched on only for short time. Thus, the offered device doesn't trail the known one in the sense of generality, and, at the same time, possesses essential advantages in the mode of welding in the air: the 2 invert circuit current of the transistors is lowered almost three-fold compared to the current (voltage excursion) in the known devices, and the conditions of the electric arc "ignition" are even somehow improved as the electrode contact with a weldment is attended by

a forced energy discharge accumulated in the filter capacitor.

**References:**

1. "DS-200 AL – Technotron" – Russia, catalog, 1995.
2. "Invertec V-130-S" – Linkoln-USA (1997).
3. Russian patent № 2242835. Secondary power source / Magazinnik L.T., Magazinnik A.G. published 20.12.2004. BI № 35.

The article is admitted to the IV conference «Innovative technologies», January, 18-28th, 2007, Тайланд, came to the editorial office on 27.04.07

**EFFICIENCY OF MODELING  
NUMERICAL METHODS USE FOR  
ANALYSIS OF TEXTILE EQUIPMENT  
WORK INTENSITY**

Nazarova M.V., Bereznyak M.G.  
*Kamyshin State Institute*

*Branch of Volgograd State Technical University  
Kamyshin, Volgograd Region, Russia*

In recent time in connection with stiff competition of textiles at fresh stock fabrics manufacturing in domestic market of Russia the problems of accelerated development of production cycles and performing express-monitoring of textile equipment work intensity for providing optimum performance of its work and obtaining high quality fabrics have become ones of the current interest.

The work intensity valuation of textile equipment is carried out with the help of special means of measurement using tensometry method. The advanced native weaving machinery work intensity measuring device is express-diagnostic tools of various modifications.

The thread tension is known to be the main parameter characterizing the tools' and machines' work intensity. In textile production activity threads are affected by stretching forces and frictional ones taking place between the thread and guiding devices of the machines and tools. If the parameters are preset rationally the deterioration of physical and mechanical properties of the thread doesn't occur. Only insignificant decrease of thread linear density on

account of trash removal and thread elongation decrease as the result of their extension because of axial forces action are observed. Thus, the production cycle should be organized in such a way that yarn and plies were subject to different on direction and scale tensile loads as less as possible.

In this investigation for valuation of work intensity of weaving machinery the express diagnostic tool of the firm "Metrotex", into which a stretch tester designed for running thread stretch measuring and applied for the diagnostics, processing equipment setup, stretch values nominal deviations elimination is included, is used. The result of thread tension measuring with the help of this installation is an experimental diagram of thread tension dependence on time.

For the weaving machinery work intensity valuation and the subsequent analysis of the process it is necessary to modify the experimental diagram into a mathematical model. The advanced methods for the equipment potential stress valuation and obtaining mathematical models are numerical methods of modeling. These methods were not in use earlier in connection with a large amount and computational complexity. Nowadays, in the context of powerful and effective software support appearing, the application of the specified methods, which allow achieving the result visually and quickly, became possible. At the orientation on the new process variables it will allow estimating the subsequent change of the equipment work intensity effectively.

For getting mathematical relations the numerical methods of modeling over interpolation polynomials of Stirling, Lagrange, Newton, Bessel and Chebyshev were used in this

work. The subject matter of these methods lies in the substitution of one function, which most often is known only empirically, with another one of a more simple form. In this case the opportunity of substitution of the experimental diagram or oscillogram, describing the dynamics of thread tension change through time, by mathematical models was considered.

Obtaining mathematical models with the help of the above mentioned methods is associated with a great amount of calculations and it is practically impossible without using a computer. That is why, algorithms of computerized analysis of mathematical models, describing the dependence of thread tension on time in different processes of weaving production, were developed for these methods' effective using. The realization of the developed algorithms was performed on the basis of Mathcad program.

The efficiency estimation of the obtained mathematical models was carried out in the tabular processor Excel by means of computation of relative quadratic standard error for all argument values.

In table 1 the results of efficiency estimation of the obtained mathematical models are quoted.

Note – the most accurate values are underlined and marked.

The analysis of the table 1 data allows making the following conclusions:

1. At weaving production activities it is preferable to use the considered in this paper numerical modeling methods as they allow obtaining the mathematical models which reflect the real process with a high enough accuracy ( $\delta < 10\%$ );

**Table 1.** Relative quadratic standard error indexes  $\delta$  (%) for different weaving production activities.

Activity	Stirling polynomial	Newton polynomial	Lagrange polynomial	Bessel polynomial	Chebyshev polynomial
Reeling	1,45	<u>0,87</u>	1,45	2,41	11,03
Warping	<u>6,58</u>	<u>6,58</u>	6,59	7,45	7,53
Dressing	<u>7,10</u>	<u>7,10</u>	<u>7,10</u>	7,60	14,27
Weaving	2,76	<u>2,37</u>	<u>2,37</u>	4,82	37,22

2. The most effective method for mathematical modeling of 25 tex linear density cotton yarn reeling process on reeling machine M-150-2 is the method with use of Newton

polynomial, the relative quadratic standard error at the interpolation step  $h=2$  makes  $\delta = 0,87\%$ ;

$$P(x) := 0.5 - 0.0815u + 0.51 \cdot u^2 - 0.4 \cdot u^3 + 0.15 \cdot u^4 - 0.0215u^5 - 0.00055u^6 + 0.00039u^7 - 0.000024u^8$$

3. The most effective method for mathematical modeling of 35,7 tex linear density cotton yarn warping process on warping machine ЦП-180 is the method with use of Stirling and Newton polynomials, the relative

quadratic standard error at the interpolation step  $h=2$  makes  $\delta = 6,58\%$ ;  
The mathematical model obtained with use of Stirling polynomial:

$$P(x) := 10.3 + 35.99u - 92.5u^2 + 90.72u^3 - 44.45u^4 + 11.99u^5 - 1.81u^6 + 0.14u^7 - 0.00456u^8$$

The mathematical model obtained with use of Newton polynomial:

$$P(x) := 10.3 + 35.99u - 92.5u^2 + 90.72u^3 - 44.45u^4 + 11.99u^5 - 1.81u^6 + 0.14u^7 - 0.00456u^8$$

4. The most effective method for mathematical modeling of 18,5 tex linear density cotton yarn dressing process on slashing machine ШБ-11/180 is the method with use of Stirling, Newton and Lagrange polynomials,

the relative quadratic standard error at the interpolation step  $h=4$  makes  $\delta = 7,10\%$ ;  
The mathematical model obtained with use of Stirling polynomial:

$$P(x) := 8 - 0.18 \cdot u - 3.53 \cdot u^2 + 0.11 \cdot u^3 + 0.72 \cdot u^4$$

The mathematical model obtained with use of Newton polynomial:

$$P(x) := 4.88 - 7.81 \cdot u + 13.13u^2 - 5.67u^3 + 0.72u^4$$

The mathematical model obtained with use of Lagrange polynomial:

$$P(x) := 4.88 - 1.95x + 0.82x^2 - 0.088x^3 + 0.0028x^4$$

5. The most effective method for mathematical modeling while manufacturing sheeting cotton fabric art. 262 on textile machine СТБ-2-216 is the method with use of Newton and Lagrange polynomials, the relative quadratic standard error at the

interpolation step  $h=40$  degrees (the shaft angular deflection of the machine tool station) makes  $\delta = 2,37\%$ .  
The mathematical model obtained with use of Newton polynomial:

$$P(x) := 0.25 - 2.32u - 0.019u^7 + 0.001u^8 - 0.95u^5 + 3.13u^4 - 6.03u^3 + 6.12u^2 + 0.17u^6 - 0.000027u^9$$

The mathematical model obtained with use of Lagrange polynomial:

$$P(x) := 0.25 - 5.79 \cdot 10^{-2} \cdot x + 3.83 \cdot 10^{-3} \cdot x^2 - 9.41 \cdot 10^{-5} \cdot x^3 + 1.22 \cdot 10^{-6} \cdot x^4 - 9.24 \cdot 10^{-9} \cdot x^5 \dots \\ + 4.21 \cdot 10^{-11} \cdot x^6 - 1.14 \cdot 10^{-13} \cdot x^7 + 1.67 \cdot 10^{-16} \cdot x^8 - 1.03 \cdot 10^{-19} \cdot x^9$$

**References:**

1. Nikolayev S.D., Martynova A.A., Yukhin S.S., Vlasova N.A. Methods and means of weaving activities research. – M., 2003 – p.365.  
2. Vinogradov Yu.S. Mathematical statistics and its application in textile and tailoring

industry. – M.: Lyogkaya Industria/Light Industry, 1970 – p. 312.

The article is admitted to the International Scientific Conference “The newest technological decisions and the equipment”, May, 14-16th 007, Moscow, came to the editorial office on 23.04.07

**VEGETATIVE REACTIONS TO  
VESTIBULAR IRRITATION AT SKI  
JUMPING PRACTICE**

Chinkin A.S., Husnullina R. I.

*Kama state institute of physical culture*

There were surveyed vestibular reactions of ski jumpers in sportsmen groups of 9, 11, 14 and 17 years (96 persons), having sports qualification from beginners (9-years) up to masters of sports of Russia (17-years). Control groups included children of the same age who are not going in for sports (58 persons). A functional condition of the vestibular analyzer was judged by the size and duration of the vegetative reactions arising in reply to vestibular irritation - rotary test of I. Vojachek.

Researches have shown, that sportsmen's pulse of all age groups after rotary test increases, but at children groups of 11 and 14 years which are not going in for sports, decreases. Thus the least increase of pulse at sportsmen group and least decrease of pulse at control examinees in age group of 17 years have been revealed. Reactions of systole pressure upon vestibular irritation at sportsmen group and their control contemporaries also have essential distinctions. The systole pressure has increased in age groups of 14 and 17 at sportsmen groups, and it has decreased at control examinees. In age groups of 9 and 11 years the reaction of systole pressure mainly decreases both at trained, and at control examinees. Hence, in all age groups of control examinees negative reaction of systole pressure on the vestibular irritation, gradually weakening from age to age and achieving a minimum level by 17 years.

Diastole pressure in reply to rotary loading in all researched groups has changed in the opposite direction to the change of systole pressure. The different reactions of systole and diastole pressures on rotary test has essentially influenced on expressiveness of changes of pulse pressure: at control examinees it has decreased in all age groups, and at sportsmen of advanced ages has essentially increased. As a whole, the age changes of pulse pressure in reply to rotary loading repeats changes of systole pressure, but it is more expressed. The negative orientation of changes of these parameters at control examinees, no less than changes pulse, is

connected, obviously, with weak activation sympato-adrenaline system at vestibular irritation. The proper response testifying to greater stability of vestibular sensory system to irritants, prevalence of sympathetic influences (Kurashvili A.E., Babijak V.K., 1975 is; Janov J., etc. 2000).

At studying vestibular stability by technique of Lozanov-Bajtchenko in both groups of examinees of 9 years it has been revealed that it is essential below, than in other age groups. The increase of vestibular stability is observed in age groups of 11 and 14, however at sportsmen group it was considerably above, than at their contemporaries from control groups. At the same time the average indices of researched sportsmen groups and control examinees of 17 years in essence do not differ. It means, that the tendency to rapprochement of parameters of sportsmen and control examinees down to their full alignment by 17 years is observed at comparison of all vestibular-vegetative reactions. It is obvious, ski jumping practice accelerate functional becoming of the vestibular analyzer, promote development of physiologically expedient orientation of vegetative reactions to vestibular irritation, but provide, finally, only usual or a little above usual level of its stability to angular accelerations. We shall note, however, that such conclusion fairly only in the event that the estimation of vestibular stability is carried out on size of vegetative reactions. It, probably, is connected by that the level of achievements in ski jumping, unlike cyclic kinds of sports, does not depend directly on development of vegetative functions. Thereof vegetative reactions to vestibular irritation, no less than vegetative functions, at even enough qualified ski jumpers, not so considerably differ from parameters of unexercised persons.

At ski jumping the main role is played with receptors of muscles of a neck, the impellent device and impellent sensory system as a whole in preservation of balance and optimum aerodynamic position of a body in flight and in maintenance of greater range of a jump. These structures reach greater functional perfection with improvement of professional skill of sportsmen, than vegetative bodies, and they also reach much greater stability to forcing down influences of vestibular irritation. On our data, the vestibular irritation causes increase in force of a brush at sportsmen group of 17-years, does not render

negative influence on kinesthetic sensitivity whereas at control examinees these parameters worsen. Also that is remarkable, intergroup distinctions do not decrease on these parameters with the years, and tend to increase.

---

The article is admitted to the International Scientific Conference “Innovative technologies in medicine” July, 8-15th 2007, Spain, came to the editorial office on 15.05.07

## *Materials of the Conferences*

### **MODERN CONCEPTS OF MONEY FLOWS CONTROL ON BASIS OF ACCOUNTING INFORMATION**

Khakhonova N.N.  
*RSEU "RINE"*

In foreign theory of money flows control the concept of Total (complex) money control (TMC), the founder of which is A. King, has lately formed and actively been developing. The system of Total (complex) money control represents the extension of the concept of TQC – Total quality control, which has become the ideology of the modern business. The main idea of the TMC is controlling the flows of money in the course of adoption of every decision by every manager.

For Russian enterprises and organizations not money flows control but treasury management is indicative. The treasury management means financial resources and their channels control in the process of formation and behavior, distribution and secondary distribution, and also using; it is a conscious and purposeful action on economic contacts conditioned by mutual settlements between economic agents, currency circulation for getting optimal eventual outcome of the managing.

The money flows control should be carried out in the frames of an enterprise fiscal policy which is understood as a general financial ideology which the enterprise follows. The task of the fiscal policy is constructing treasury management effective system which provides the achievement of strategic and tactical targets of the enterprise activity.

The strategic and tactical aspects of the fiscal policy are closely interfacing: the adequate choice of strategy creates favourable opportunities for tactical tasks solution.

Really, the rates of strategic development and business solvency of an enterprise to a great extent are defined by how cash flows are synchronized against each other in time and terms of volume as a high level of such synchronization provides accelerated realization of the chosen business purposes.

Undoubtedly, rational formation of money flows promotes line balance and provides increase in production and realization of outputs. At that, any payment discipline violation has an adverse effect on productive supplies formation, performance level, finished commodity realization, the position of an

enterprise in the market, etc. Even in the enterprises successfully operating in the market and generating enough value of returns a pay inability can appear as a consequence of imbalance of different kinds of money flows in time.

On the other hand, this money flows control is an important factor of an enterprise's capital turnover acceleration. It is accounted for operating cycle duration reduction, more economical use of the inhouse and lessening of need in borrowed sources of cash. Consequently, the performance efficiency on a business entirely depends on the money flows control system organization.

The money flows control as the one of financial flows' component should be one of the most important business lines of a financial manager. Founding on the research of foreign and Russian authors, let us carry out the adaptation of the scientific idea development to the system of money flows control in Russian enterprises and organizations, and try to introduce the authors approach to the money flows control concept realization conditions and comprehension. In our opinion, the money flows control involves the accounts and cash resources control in the course of business transaction performance, flow-of-funds analysis and prognostics, cash resources optimal level determination, cash resources budget preparations, etc.

The essence of the money flows control defines the formation and functioning of this management class as a system.

The money flows control system is a form of interaction and control relations development realization, expressed, first of all, in management laws and principles and also in purposes, functions, structure, methods, process and mechanism of control. The given system is created for the performance of short and strategic projects of an enterprise, financial responsibility and business solvency retention, more rational use of its assets and sources of funds, and also business function financing facility cost minimization.

First all, let us specify the basic components of the research – the object and the subject.

The object of the money flows control is a thing where the cognitive and other activities are aimed at – it is a system of finance-economic intercourse appearing in the process of cash flows and financial instruments. Therefore, the objects of

control, in the author's opinion, should be not only money flows but also financial (cash) resources, and also the cost and the capital structure.

The subject of the money flows control is fixed in experience and involved in the process of human practical activity sides, properties and relations of the objects studied with a certain purpose under given conditions and circumstances. Respectively, we think it is necessary to consider an enterprise's money flows, which can function in different levels bearing an interconditioned character, to be the subject of control:

- 1) at the level of an economic unit in the whole;
- 2) by activity kinds (operating, investing, financial);
- 3) by segments of an enterprise's activity;
- 4) by business processes;
- 5) by organizational units of an enterprise;
- 6) by responsibility centers;
- 7) by separate commodity lines and business transactions.

The mechanism of money flows control is created and purposefully changed by the people who perform the regulatory activity of the total aggregate of functions, forms, methods, levers and incentives to achieve its highest efficiency in concrete economic conditions.

Actual money flows control in market conditions is possible only on the ground of effective accounts which is the data base to define the strategy and tactics of both internal and external control. The development and performance of management solutions are based on planned, standard, process, discount and analysis information. From the management view point the accounts should be considered as an information system involving fiscal, management and strategic accounting. It is the accounting data that make up the data base for the money flows analysis which, in its turn, allows planning the cash flow for the coming period more rationally.

Within the system of fiscal accounting the information reflecting the state and cash flow of an enterprise for an accounting period and necessary for the performance of the current management is formed. It is represented in a generalized form on the accounts of business accounting and can be itemized by analytical findings attraction. The fiscal accounting data are the most exact and available for the data users. However, in the aggregate form this information is not complete, operative and sufficient

to accept policy decisions and, in this connection, should be performed by other information forms.

Within the system of fiscal accounting the information about the money flows of separate organization departments, responsibility centers, different kinds of activity and concrete operations having provoked the cash flow is formed and used in day-to-day management as a rule.

The fiscal and management accounting data for effective money flows control are evidently insufficient. It is explained by the fact that the given accounting systems operate generally with the information about actually performed economical and financial services.

The 90-s became the time of business struggle go-go modification of terms in the world's economics, the new strategic thinking being more and more associated with business globalization and, finally, with passing to a new model of economic growth. The change from a traditional industrial economy to resilient economics, especially in industrially advanced countries, requires the creation of suitable discount-analytical provision of policy decisions taking in the field of money flows control on the basis of the system approach. The discount-analytical provision in the microlevel is the foundation for policy definition of a firm and for the definition of alternative approaches to the management practice. The solution of the given problem is the formation and development of strategic accounts as a whole (and money flows in particular).

The strategic accounts represent a global model of information technology which provides the administrators and specialists of an enterprise with the proprietary information for taking effective decisions and also provide the investing public with the information for an enterprise activity assessment. In the strategic accounts system the information about opportunity costs and business struggle, marketing policy of a firm, financial and money risks, inflationary expectations, etc. It is the money flows strategic accounts system that should be the information basis for the strategic management performance.

The foundation of management is the availability of operating and exact accounting information based on the bookkeeping and managerial accounting. The composition of such information is rather diverse: movement on accounts and in the booking office of an enterprise, earnings/receivables and payables of an enterprise, tax payments budgets, credit accommodation and

redemption organization plans, payments of interest, procurement activities requirements demanding prepayment, and much of the sort. The information itself arrives from different sources; its acquisition and collation should be tried and tested with particular care as lagging and errors at the information delivery can lead to severe effects for the company as a whole. At that every enterprise defines the form of delivery, information acquisition frequency and flow of documents scheme.

The importance and value of the money flows control at an enterprise is difficult to overestimate as not only soundness of an enterprise at a definite time

period, but also its further development capability and financial success achieving for a long-term prospects depend on its quality and effectiveness.

---

The article is admitted to the International Scientific Conference “Actual problems of science and education”, Economic sciences, Cuba, March, 19-30th 2007r., came to the editorial office on 15.02.07